

EK-VT320-PS-001

VT320

Pocket Service Guide

1st Edition, July 1987

Copyright © 1987
by Digital Equipment Corporation.
All Rights Reserved.

Printed in U.S.A.

The reproduction of this material, in part or whole, is strictly prohibited. For copy information, contact the Educational Services Department, Digital Equipment Corporation, Maynard, Massachusetts 01754.

The information in this document is subject to change without notice. Digital Equipment Corporation assumes no responsibility for any errors that may appear in this document.

The following are trademarks of Digital Equipment Corporation, Maynard, Massachusetts.

DEC ™	LA50, LA75	UNIBUS
DEC	LN03	VAX
DECconnect	MASSBUS	VMS
DECmate	MicroVAX	VT
DECnet	MicroVMS	VT52
DECpage	PDP	VT100
DECserver	P/OS	VT101, VT102
DECsystem-10	Professional	VT125, VT131
DECSYSTEM-20	Rainbow	VT220
DECtalk	ReGIS	VT240, VT241
DECUS	RSTS	VT320
DECwriter	RSX	VT330, VT340
DIBOL	SSU	Work Processor

This manual was prepared using DECpage software.

CONTENTS

About This Guide

The VT320 Video Terminal	v
Tools Required.	vi
Warnings, Cautions, and Notes	vi

1 Testing and Troubleshooting

1.1	General	1
1.2	Troubleshooting General Problems	1
1.3	VT320 Self-Tests	7
1.3.1	Before You Start	7
1.3.2	Power-Up Self-Test	8
1.3.3	DEC-423 Port Loopback Test	11
1.3.4	RS232 Port Data Lines Loopback Test	13
1.3.5	RS232 Port Control Lines Loopback Test	14
1.3.6	Printer Port Loopback Test	15
1.3.7	Screen Alignment Test	16
1.4	Printer Problems	16
1.5	Error Codes	17

2 Removing and Replacing FRUs

2.1	General	19
2.2	Access Cover	19
2.3	Power Supply Assembly	21
2.4	CRT/Bezel/Yoke Assembly	25
2.4.1	CRT Disposal	28
2.5	Monitor and Logic with Arc Protection Assembly	32
2.6	Keyboard	33

3 Aligning the Video Monitor

3.1	General	35
3.2	Monitor Adjustments	35
3.2.1	Before You Start	36
3.2.2	Displaying the Screen Test Pattern	36
3.2.3	Screen Control.	37

iv CONTENTS

3.2.4	Subcontrast	37
3.2.5	Rotation	38
3.2.6	Horizontal Width	39
3.2.7	Vertical Height	39
3.2.8	Vertical Linearity	39
3.2.9	Centering	40
3.2.10	Focus	40

4 Using Set-Up

4.1	General	41
4.2	Displaying Set-Up Screens	41
4.3	Changing Settings.	42
4.4	Saving Set-Up Values	43
4.5	Recalling Set-Up Values	43

A Options and Documentation

B VT320 Models and Recommended Spares

C Physical/Functional Diagrams

Figures

1-1	VT320 Video Terminal.	2
1-2	VT320 Troubleshooting Flowchart	3
1-3	Successful Power-Up Self-Test Display.	9
1-4	VT320 Rear Connector Panel and Loopback Connectors	12
3-1	Monitor Adjustment Controls	35
3-2	Rotation and Centering Adjustments	38
4-1	VT320 Set-Up Screen	42
A-1	VT320 Cables	45
C-1	VT320 North American Model	49
C-2	VT320 International Model	50

Tables

1-1	Troubleshooting the VT320	4
1-2	VT320 Self-Test Chart	10
1-3	VT320 Display Error Codes	18

ABOUT THIS GUIDE

This guide describes how to service the VT320 monochrome video terminal. The guide is for Digital Field Service personnel.

The guide covers the following topics.

Testing and troubleshooting
Removing and replacing field replaceable units (FRUs)
Adjusting the video monitor
Using set-up

Appendices provide information on the following topics.

Options and related documentation
VT320 models and recommended spares
Physical/functional diagrams

THE VT320 VIDEO TERMINAL

The VT320 is a monochrome text-only terminal that provides VT220 compatibility with enhancements. The VT320 has a 355.6 mm (14 inch) monitor with a flat, antiglare screen. The monitor can display 24 lines of text in 80- or 132-column format. The 25th display line is reserved for a status line. A built-in tilt mechanism lets the user adjust the viewing angle for optimum comfort.

There are two models of the VT320 video terminal.

International model

- Supports many national replacement character sets (NRCs) for European languages.
- Has two system communication ports: a 25-pin RS232 port and a 6-pin DEC-423 port.
- Has a detachable power cord.

vi ABOUT THIS GUIDE

North American model

- Similar to the international version, but does not support the NRC sets.
- Has only one system communication port: a 6-pin DEC-423 port.
- Has an attached power cord.

TOOLS REQUIRED

You need the following tools to service the VT320 video terminal.

Tool	Part Number
Anode discharge tool	29-24717-00
25-pin RS232 EIA loopback connector	12-15336-00
Metric measuring tape	29-25342-00
6-pin DEC-423 loopback connector (modular jack)	12-25083-01
Phillips screwdriver, number 2	29-11005-00
Slotted screwdriver, 1/4 inch	29-10983-00
Tuning wand	29-23189-00
Video alignment tool	29-26128-00

WARNINGS, CAUTIONS, AND NOTES

The warnings, cautions, and notes in this guide have specific purposes.

WARNING Contains information to prevent personal injury.

CAUTION Contains information to prevent damage to equipment and software.

NOTE Contains general information you should be aware of.

1 TROUBLESHOOTING AND TESTING

1.1 GENERAL

This chapter describes how to troubleshoot general problems with the VT320 video terminal (Figure 1-1). The chapter also describes how to run the self-tests built into the terminal, and lists error codes for the tests.

1.2 TROUBLESHOOTING GENERAL PROBLEMS

Figure 1-2 is a flowchart to help you diagnose and troubleshoot any VT320 operating problems. When you use the flowchart, remember the following facts.

- The DC OK indicator is inside the terminal. To see this indicator, look through the ventilation slits on the top of the terminal (Figure 1-1). The DC OK indicator is the small green LED on the power supply assembly.
- When you turn on the terminal, the keyboard's LED indicators (Figure 1-1) go through a power-up sequence. During this sequence, the LEDs flash on and off repeatedly.

At the end of the sequence, the keyboard makes a bell tone and all the LEDs turn off.

- At the end of a successful power-up, a "VT320 OK" message appears on the screen.

2 TROUBLESHOOTING AND TESTING

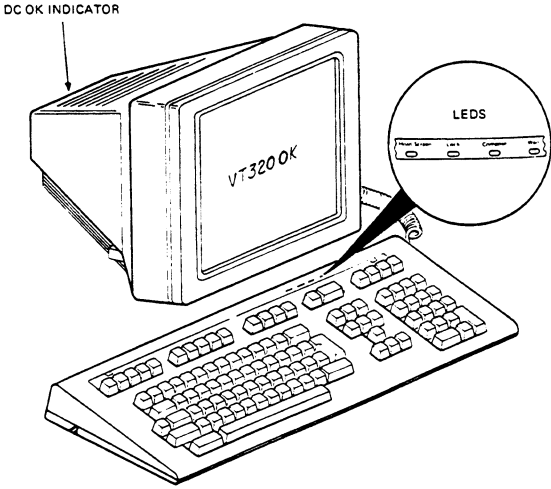

MA-0182A-87

Figure 1-1 VT320 Video Terminal

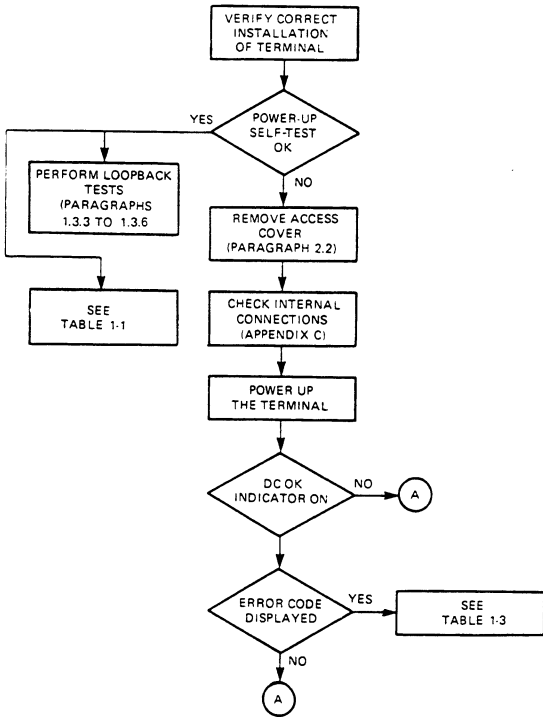

MA 0851-87

If Nothing Appears on the Screen

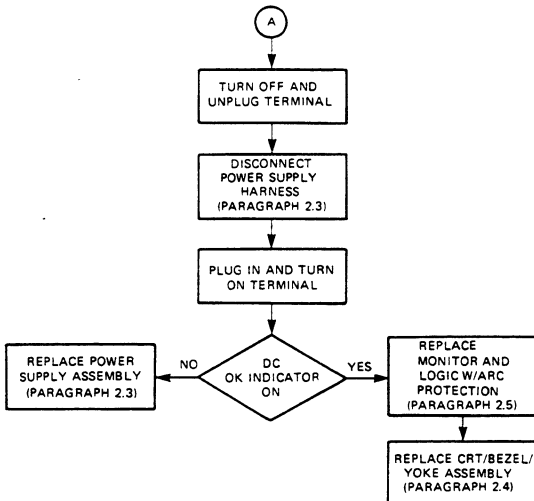

MA 0852-87

Figure 1-2 VT320 Troubleshooting Flowchart

4 TROUBLESHOOTING AND TESTING

Table 1-1 Troubleshooting the VT320

Symptom	Probable Cause	Solution*
Nothing appears on the screen.	Power supply assembly	See the troubleshooting flowchart (Figure 1-2, "If Nothing Appears on the Screen").
	CRT/bezel/yoke assembly	
VT320 OK display appears. DC OK indicator is on. bell tone sounds. VT320 cannot communicate with host.	VT320 communication port cable is loose.	Check the cable connection on the rear of terminal.
	Communication port circuits are faulty.	Run the RS232 or DEC-423 loopback tests. (1.3.3, 1.3.4, 1.3.5).
	Baud rate is incorrect.	Check the Transmit and Receive speeds in the Communications Set-Up screen.
Horizontal or vertical line appears on screen.	Monitor and logic with arc protection assembly	Replace the monitor and logic with arc protection assembly (2.5).
	CRT yoke harness connector	Check and reconnect the connector (2.4).
	Monitor and logic with arc protection assembly	Replace the monitor and logic with arc protection assembly (2.5).
Screen display distorted.	CRT and yoke	Replace the CRT/yoke/bezel assembly (2.4).
	Monitor is out of alignment.	Align the monitor (Chapter 3).
	Monitor and logic with arc protection assembly	Replace the monitor and logic with arc protection assembly (2.5).
Screen display jittery.	CRT and yoke	Replace the CRT/yoke/bezel assembly (2.4).
	Monitor and logic with arc protection assembly	Replace the monitor and logic with arc protection assembly (2.5).

* Paragraph numbers are in bold type.

Table 1-1 Troubleshooting the VT320 (Cont)

Symptom	Probable Cause	Solution*
No bell tone. but "VT320 OK" appears on screen.	Keyboard cable is not connected properly.	Check the keyboard connection on the right side of the terminal.
	Keyboard speaker transducer	Replace the keyboard (2.6).
Different characters appear on screen then were typed in local.	Alternate character set selected.	Clear by selecting the Reset feature in the Set-Up Directory.
	International only: Wrong keyboard language selected.	Check the keyboard language setting in the Set-Up Directory.
	Keyboard	Replace the keyboard (2.6).
	Monitor and logic with arc protection assembly	Replace the monitor and logic with arc protection assembly (2.5).
Different characters appear on screen than were typed while on-line with host. (Terminal works in local mode.)	Transmit and receive speeds are wrong.	Set the speeds to match the host (Communications Set-Up).
	Bits per character or parity setting is wrong.	Set the <u> </u> Bits , <u> </u> Parity feature to match the host (Communications Set-Up).
	Stop bits setting is wrong.	Set Stop Bits feature to match the host (Communications Set-Up).
	Monitor and logic with arc protection assembly	Replace the monitor and logic with arc protection assembly (2.5).
Screen display does not scroll. Hold Screen indicator is on.	Hold Screen key was pressed.	Press the Hold Screen key to resume scrolling.
Terminal appears locked. does not respond to data from host.	—	In the Set-Up Directory: 1. Select Clear Comm to clear the terminal. Then 2. Select Reset to reset the terminal.

* Paragraph numbers are in bold type.

6 TROUBLESHOOTING AND TESTING

Table 1-1 Troubleshooting the VT320 (Cont)

Symptom	Probable Cause	Solution*
Screen is blank. except for blinking block cursor in lower-right corner. Screen has been inactive for one-half hour.	CRT saver feature is activated.	Press any key to restore the screen display.
Messages are garbled.	XON/XOFF flow control not enabled.	Enable XON/XOFF flow control with the <u>XOFF</u> feature in Communications Set-Up.
	Monitor and logic with arc protection assembly	Replace the monitor and logic with arc protection assembly (2.5).
Terminal does not respond to escape sequences.	Incorrect mode settings	Select "VT100 Mode" in General Set-Up. Select "Local" mode in the Set-Up Directory.
After power-up, one or more keyboard LEDs stays on. Or, the LEDs do not go through power-up sequence.	Keyboard	Replace the keyboard (2.6).
	Monitor and logic with arc protection assembly	Replace the monitor and logic with arc protection assembly (2.5).
The set-up cursor does not appear.	Monitor and logic with arc protection assembly	Replace the monitor and logic with arc protection assembly (2.5).
When using a modem, the modem speed select signals do not work.	Monitor and logic with arc protection assembly	Replace the monitor and logic with arc protection assembly (2.5).

* Paragraph numbers are in bold type.

1.3 VT320 SELF-TESTS

The VT320 has a series of self-tests to help you isolate failures to faulty field replaceable units (FRUs) in the terminal. You run each test from the keyboard, by entering the escape sequence for the test. Table 1-2 lists the tests and their escape sequences.

If a test finds a faulty FRU, adjust or replace the faulty unit. Then repeat the tests in this chapter, to ensure the terminal operates correctly.

1.3.1 Before You Start

Before you run any self-test, you must set the terminal to local mode and VT100 mode, as follows.

NOTE

If you are unfamiliar with set-up, see Chapter 4.

1. Press **Set-Up** to enter set-up. The **Set-Up Directory** appears.
2. Use the arrow keys to move the cursor to the "On Line" setting. Press **Enter** to change the setting to "Local".
3. Use the arrow keys to move the cursor to "General". Press **Enter** to display the **General Set-Up** screen.
4. Use the arrow keys to move the cursor to the operating mode feature. Use the **Enter** key to change the setting to "VT100 Mode".
5. Press **Set-Up** to leave set-up.

Remember to reset set-up features to their original setting after testing.

8 TROUBLESHOOTING AND TESTING

1.3.2 Power-Up Self-Test

This test runs automatically each time you turn on the terminal. The test checks the terminal's internal memory, keyboard, and video circuitry. The test also checks the communication and printer ports, to see if they are operating correctly. The individual loopback tests perform a more complete test of each port.

You can also run the power-up self-test while the terminal is operating, as follows.

NOTE

After you run the power-up self-test, all the set-up features are set to their saved values.

1. Set the terminal to "Local" mode and "VT100 Mode" (Paragraph 1.3.1).
2. Type one of the following sequences.
`ESC [4; 1 y` Runs the test once.
`ESC [4; 1; 9 y` Runs the test continuously.

NOTE

The continuously running self-test ends only if an error occurs or you turn off the terminal. The keyboard does not make a bell tone during this test.

A successful power-up self-test ends as follows (Figure 1-3).

1. The keyboard's LED indicators are off.
2. The keyboard makes a bell tone.
3. A "VT320 OK" message appears on the screen. This message disappears when any of the following occur.

The terminal receives any character except XON, XOFF, or NULL.

You press any key.

You leave the terminal on but inactive for 30 minutes.

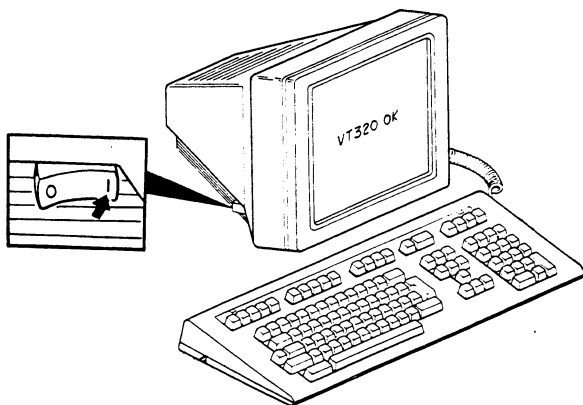

MA 0187 87

Figure 1-3 Successful Power-Up Self-Test Display

If the Test Finds an Error

First look at the screen. The terminal will display one or more error messages. Each error message starts on a new line at the left margin of the display. Table 1-3 describes these error messages.

If the screen display is faulty, check the keyboard LED indicators. If one or more of the indicators stays on, replace the monitor and logic with arc protection assembly (Paragraph 2.5).

10 TROUBLESHOOTING AND TESTING

Table 1-2 VT320 Self-Test Chart

Self-Test	Prerequisites	Sequence*
Power-up	None	Turn the terminal on.
Power-up (selected while VT320 is operating)	Set-up - Local - VT100 Mode	Once: ESC [4 ; 1 y Continuously: ESC [4 ; 1 ; 9 y
RS232 port data lines loopback †	Set-up - Local - VT100 Mode RS232 loopback connector	Once: ESC [4 ; 2 y Continuously: ESC [4 ; 2 ; 9 y
RS232 port control lines loopback †	Set-up - Local - VT100 Mode RS232 loopback connector	Once: ESC [4 ; 6 y Continuously: ESC [4 ; 6 ; 9 y
Printer port loopback	Set-up - Local - VT100 Mode DEC-423 port loopback connector	Once: ESC [4 ; 3 y Continuously: ESC [4 ; 3 ; 9 y
DEC-423 port loopback	Set-up - Local - VT100 Mode DEC-423 loopback connector	Once: ESC [4 ; 7 y Continuously: ESC [4 ; 7 ; 9 y
Screen alignment pattern	Set-up - Local - VT100 Mode	ESC # 8
Run all above tests, except screen alignment pattern.	See individual tests. All loopback connectors must be connected.	Once: ESC [4 ; 0 y Continuously: ESC [4 ; 0 ; 9 y

* Do not type spaces between the characters in any escape sequence. The sequences are shown with spaces for clarity only. ESC is the Esc key (F11) on the top row of the keyboard.

† International model only.

1.3.3 DEC-423 Port Loopback Test (6-Pin)

For this test, you connect the DEC-423 port transmit and receive data lines together with a loopback connector (Figure 1-4). The terminal sends a predefined set of characters on its transmit line and receives them on its receive line. Then the terminal compares the output characters to the input characters. If the characters do not match, an error message appears on the screen.

Run the test as follows. Use a DEC-423 loopback connector (PN 12-25083-01).

1. Set the terminal to "Local" mode and "VT100 Mode" (Paragraph 1.3.1).
2. Connect the loopback connector to the 6-pin DEC-423 port.
3. Type one of the following sequences.
 - ESC [4; 7 y Runs the test once.
 - ESC [4; 7; 9 y Runs the test continuously.

NOTE

The continuously running test ends only if an error occurs or you turn off the terminal. The keyboard does not make a bell tone during this test.

A successful test ends as follows.

1. The keyboard makes a bell tone.
2. The keyboard's LED indicators are off.
3. A "VT320 OK" message appears on the screen.

If the test finds an error, your screen will display the following message. See Table 1-3.

VT320 DEC-423 Port Error -- 5

12 TROUBLESHOOTING AND TESTING

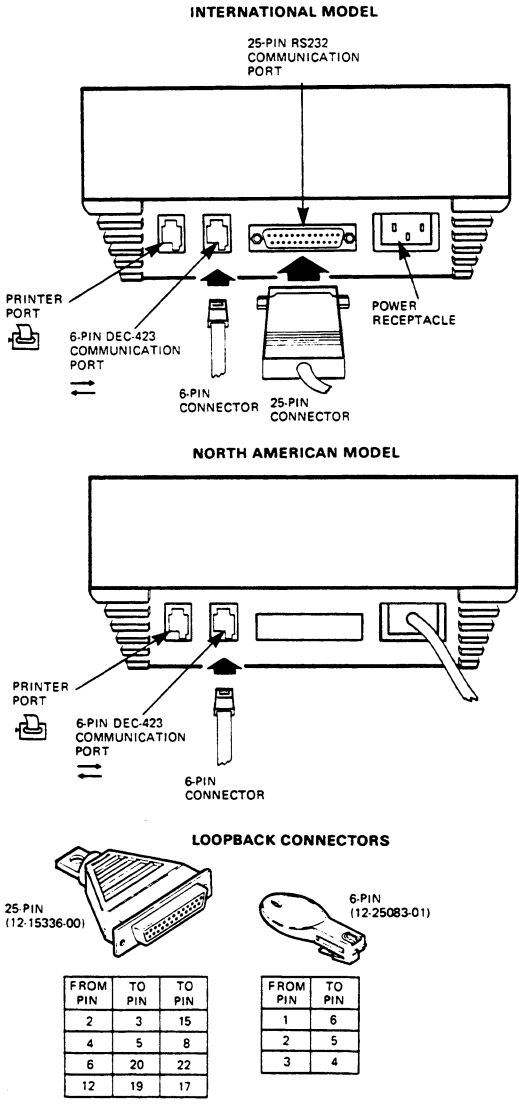

MA-0280-87

Figure 1-4 VT320 Rear Connector Panel and Loopback Connectors

1.3.4 RS232 Port Data Lines

Loopback Test

(25-Pin, International Model Only)

For this test, you connect the RS232 transmit and receive data lines together with a loopback connector. The terminal sends a predefined set of characters on its transmit line and receives them on its receive line. Then, the terminal compares the output characters to the input characters. If the characters do not match, an error message appears on the screen.

Run the test as follows. Use an RS232 loopback connector (PN 12-15336-00).

1. Set the terminal to "Local" mode and "VT100 Mode" (Paragraph 1.3.1).
2. Connect the loopback connector to the 25-pin RS232 port (Figure 1-4).
3. Type one of the following sequences.
ESC [4; 2 y Runs the test once.
ESC [4; 2; 9 y Runs the test continuously.

NOTE

The continuously running test ends only if an error occurs or you turn off the terminal. The keyboard does not make a bell tone during this test.

A successful test ends as follows.

1. The keyboard makes a bell tone.
2. The keyboard's LED indicators are off.
3. A "VT320 OK" message appears on the screen.

If the test finds an error, your screen will display the following message. See Table 1-3.

VT320 RS232 Port Data Error -- 2

14 TROUBLESHOOTING AND TESTING

1.3.5 RS232 Port Control Lines Loopback Test (25-Pin, International Model Only)

This test checks the following control signals.

Data terminal ready	(DTR)
Request to send	(RTS)
Carrier detect	(CD)
Data set ready	(DSR)
Clear to send	(CTS)

If an error occurs, a message appears on the screen. Run the test as follows. Use an RS232 loopback connector (PN 12-15336-00).

1. Set the terminal to "Local" mode and "VT100 Mode" (Paragraph 1.3.1).
2. Connect the loopback connector to the 25-pin RS232 port (Figure 1-4).
3. Type one of the following sequences.
ESC [4; 6 y Runs the test once.
ESC [4; 6; 9 y Runs the test continuously.

NOTE

The continuously running test ends only if an error occurs or you turn off the terminal. The keyboard does not make a bell tone during this test.

A successful test ends as follows.

1. The keyboard makes a bell tone.
2. The keyboard's LED indicators are off.
3. A "VT320 OK" message appears on the screen.

If the test finds an error, your screen will display the following message (Table 1-3).

VT320 RS232 Port Controls Error -- 3

1.3.6 Printer Port Loopback Test (6-Pin)

For this test, you connect the printer transmit and receive data lines together with a loopback connector. The terminal sends a predefined set of characters on its transmit line and receives them on its receive line. Then the terminal compares the output characters to the input characters. If the characters do not match, an error message appears on the screen (Table 1-3).

Run the test as follows. Use a DEC-423 loopback connector (PN 12-25083-01).

1. Set the terminal to "Local" mode and "VT100 Mode" (Paragraph 1.3.1).
2. Connect the loopback connector to the printer port (Figure 1-4).
3. Type one of the following sequences.
 - ESC [4; 3 y Runs the test once.
 - ESC [4; 3; 9 y Runs the test continuously.

NOTE

The continuously running test ends only if an error occurs or you turn off the terminal. The keyboard does not make a bell tone during this test.

A successful test ends as follows.

1. The keyboard makes a bell tone.
2. The keyboard's LED indicators are off.
3. A "VT320 OK" message appears.

If the test finds an error, your screen will display the following message (Table 1-3).

VT320 Printer Port Error -- 6

1.3.7 Screen Alignment Test

The screen alignment test fills the screen with uppercase E's. You use this display to adjust the display height, width, and linearity. See Chapter 3 for the adjustment procedures.

Run the screen alignment test as follows.

1. Set the terminal to "Local" mode and "VT100 Mode" (Paragraph 1.3.1). Also make sure the Columns setting in the Display Set-Up screen is set to "80 Columns".
2. Type ESC # 8. The screen fills with a pattern of uppercase E's.
3. Perform the adjustment procedures in Chapter 3.

1.4 PRINTER PROBLEMS

If the VT320 is connected to a local printer, you may have to troubleshoot some printer problems. The following procedure helps you isolate the problem to the printer or the terminal.

1. Run the power-up self-test (Paragraph 1.3.2). If the terminal passes the test, go to step 2.
2. Run the printer port loopback self-test (Paragraph 1.3.6). If the terminal passes this test, go to step 3.

NOTE

If your terminal passes the above tests, it is running correctly. The problem is probably not in the terminal.

3. Test the printer. See your printer's service guide for the correct procedures. If your printer is operating correctly, go to step 4.

4. Go to the Printer Set-Up screen.
 - Check the following settings. They must match the printer's settings. See your printer's service guide for the correct settings.
 - Baud rate
 - Data bits per character
 - Parity
 - Make sure "Printer Ready" appears on the VT320 status line.
5. Make sure you are using the correct cable between the terminal and printer (Appendix A). Make sure the connections are secure at both ends of the cable.
6. Set the terminal to "Local" mode and "VT100 Mode" (Paragraph 1.3.1).
7. Type the following sequence: ESC # 8.
The screen displays a test pattern of uppercase E's.
8. Press the Print Screen key. If the printer is operating correctly, the test pattern displayed on the screen should print out.

1.5 ERROR CODES

If your screen displays an error message, see Table 1-3. It lists the field replaceable unit (FRU) you must replace to correct the problem.

If there is a problem with the screen display, check the LED indicators on the keyboard. If you observe any of the following conditions, replace the monitor and logic with arc protection assembly (Paragraph 2.5).

- One or more LEDs stay on at the end of a test.
- The LEDs flash the same pattern repeatedly
- The LEDs do not turn on at all.

18 REMOVING AND REPLACING FRUS

Table 1-3 VT320 Display Error Codes

Error Message*	Solution†
NVR Error — 1	<ol style="list-style-type: none">1. Enter the Set-Up Directory.2. Select the Default feature and press Enter.3. Select the Save feature and press Enter.4. Leave set-up.5. Turn the VT320 off, then on.6. If the error continues, replace the monitor and logic with arc protection assembly (2.5).
RS232 Port Data Error — 2	Replace the monitor and logic with arc protection assembly (2.5).
RS232 Port Controls Error — 3	Replace the monitor and logic with arc protection assembly (2.5).
Keyboard Error — 4	<ol style="list-style-type: none">1. See if the keyboard is plugged in.2. Replace the keyboard (2.6).3. If the error continues, replace the monitor and logic with arc protection assembly (2.5).
DEC-423 Port Error — 5	Replace the monitor and logic with arc protection assembly (2.5).
Printer Port Error — 6	Replace the monitor and logic with arc protection assembly (2.5).

* All error messages begin with "VT320".

Paragraph numbers are in bold type.

2 REMOVING AND REPLACING FRUs

2.1 GENERAL

This chapter shows you how to remove and replace the field replaceable units (FRUs) for the VT320. See Appendix B for the recommended spares list.

CAUTION

Always use a static protection kit (PN 29-26246-00) when handling any internal components.

The chapter covers both models of the VT320, the North American and the international. Where differences occur, the North American procedure appears first, then the international procedure.

2.2 ACCESS COVER

Remove the access cover as follows.

1. Turn off the terminal and unplug the power cord from the wall outlet.
2. Place the terminal facedown on a clean piece of paper, to avoid scratching the bezel.

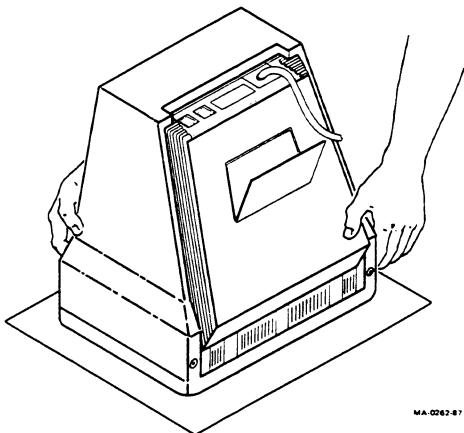

MA-0262-87

20 REMOVING AND REPLACING FRUS

3. Loosen the captive screws at the base of the CRT bezel.

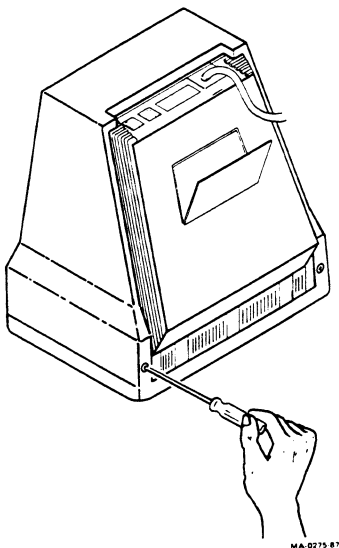

MA-0275-87

4. Grasp the rear of the access cover firmly with one hand. Place your other hand securely on the rear connector panel.

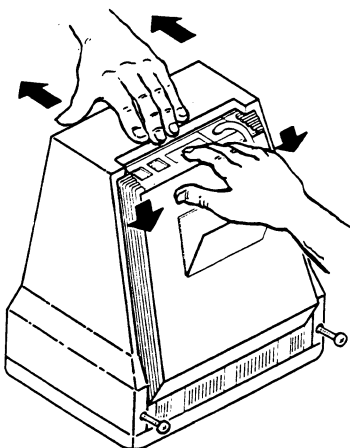

MA 0261 87

5. With your hands in position, push the bottom assembly towards the cover and pull the access cover away from the base. Place the cover aside.

To install the access cover, slide the cover down over the base. Then align and tighten the captive screws.

2.3 POWER SUPPLY ASSEMBLY

Remove the power supply assembly as follows. First remove the following FRU.

Access cover (Paragraph 2.2)

1. Turn off the terminal and unplug the power cord from the wall outlet.
2. Place the terminal right side up on its base.
3. Remove the power supply wiring harness from the power supply assembly.

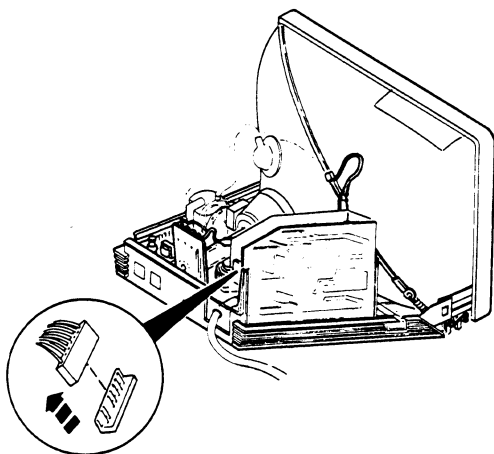

22 REMOVING AND REPLACING FRUs

4. Remove the power switch from its holder by applying pressure inside the terminal and rocking the switch forward, as shown. Then pass the switch wires up through the slot.

The on and off symbols are molded into the base of the VT320. When you reinstall the power switch, match the symbols on the switch to the symbols on the base for the correct position.

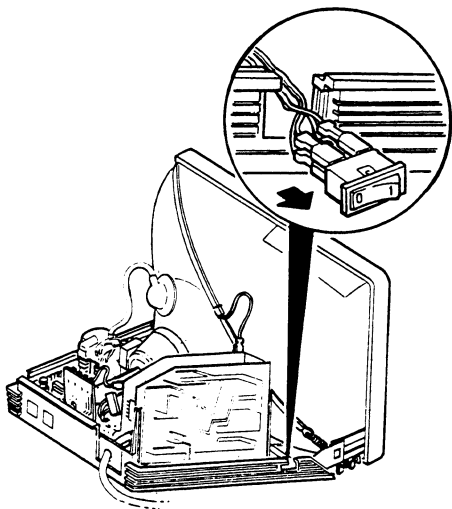

MA-0849-87

5. Disconnect the two ground connectors from the shield of the power supply assembly.
6. Use a flat-bladed screwdriver to release the tab at the base of the power supply assembly. Lift the assembly up.

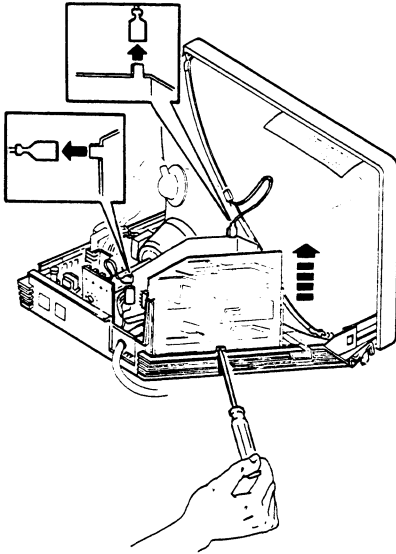

MA 0847 87

7. Slide the power supply assembly up and away from its bracket.

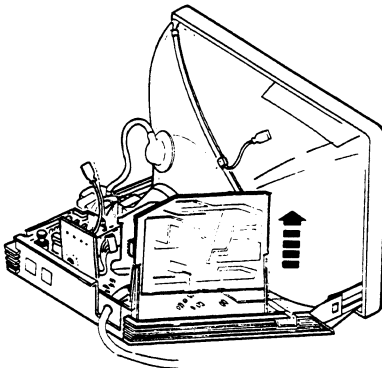

MA 0848 87

24 REMOVING AND REPLACING FRUs

8. North American model: Slide the power cord up and away from its bracket.

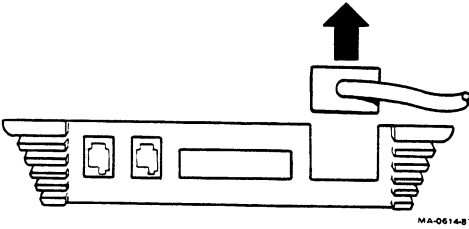

MA-0614-87

International model: Unplug the power cord from the rear of the terminal.

Slide the input power connector up and away from its bracket.

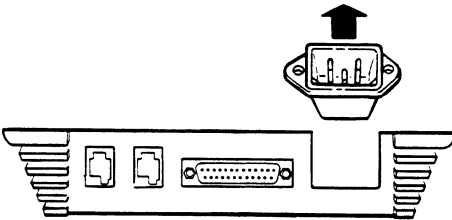

MA-0612-87

To install the power supply assembly, reverse steps 1 through 8.

NOTE

When you replace the power supply assembly in the international model, set the voltage jumper to the desired voltage.

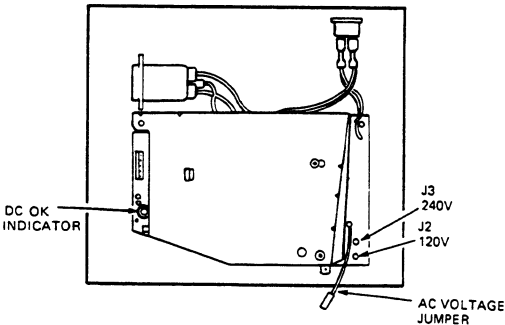

MA-0276-87

2.4 CRT/BEZEL/YOKE ASSEMBLY

Remove the CRT/bezel/yoke assembly as follows.
First remove the following FRU.

Access cover (Paragraph 2.2)

1. Turn off the terminal and unplug the power cord from the wall outlet.

WARNING

The following steps may expose you to high voltages. To protect yourself, discharge the anode with the anode discharge tool (PN 29-24717-00).

2. Discharge the anode as follows. (For clarity, the power supply assembly is not shown.)
 - a. Attach the alligator clip of the anode discharge tool to the grounding braid on the rear of the CRT.
 - b. Insert the tool under the rubber anode cap until you make contact with the anode connector. Discharge the anode for at least three seconds.
 - c. Remove the anode discharge tool.

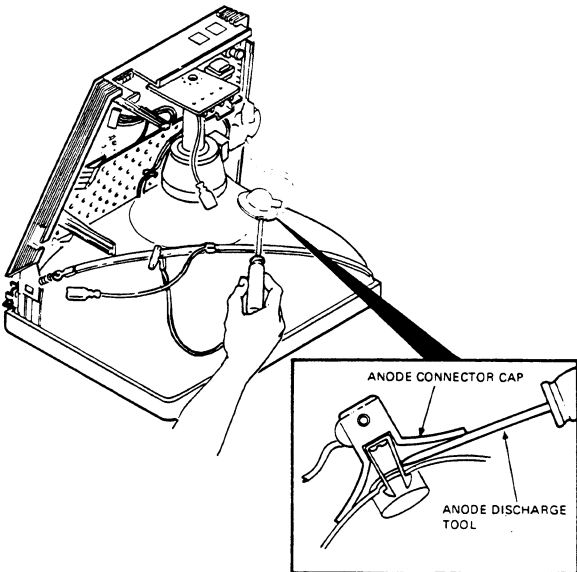

26 REMOVING AND REPLACING FRUs

3. Remove the CRT anode connector from the CRT.

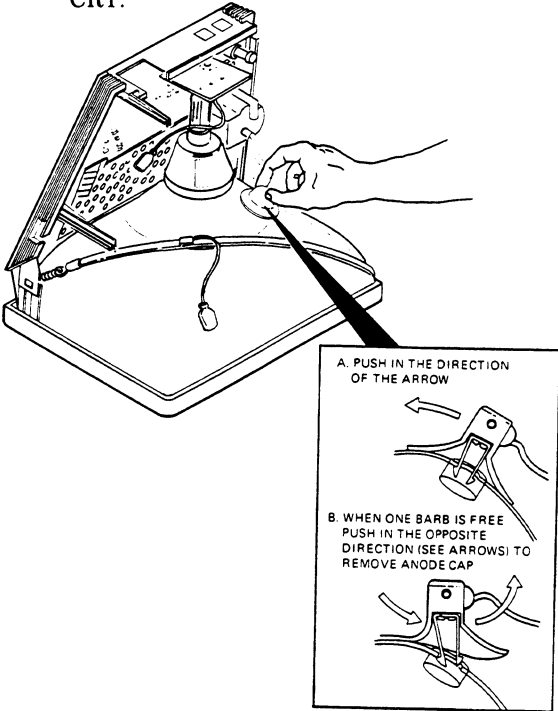

4. Disconnect the two ground connectors from the shield for the power supply assembly.

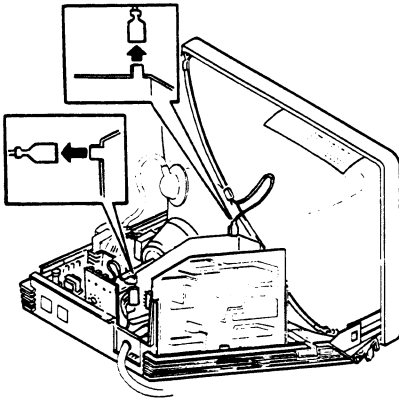

5. Remove the arc protection board from the neck of the CRT.

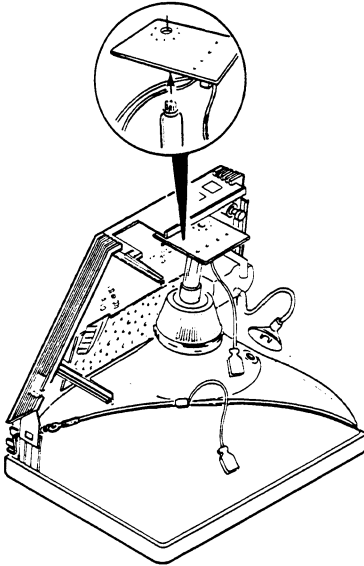

MA-0272-B7

6. Remove the yoke wiring harness from the monitor and logic with arc protection assembly.

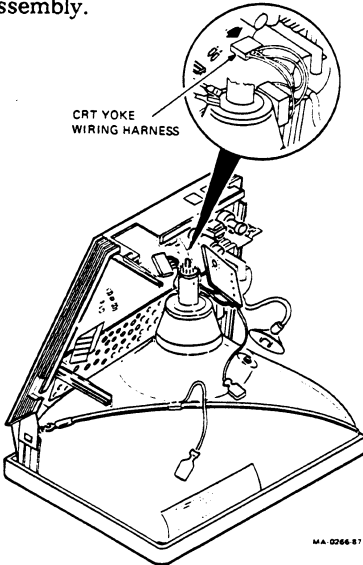

MA-0266-B7

28 REMOVING AND REPLACING FRUS

7. Release the connector tabs at the base of the CRT and lift the base away from the CRT/bezel/yoke assembly.

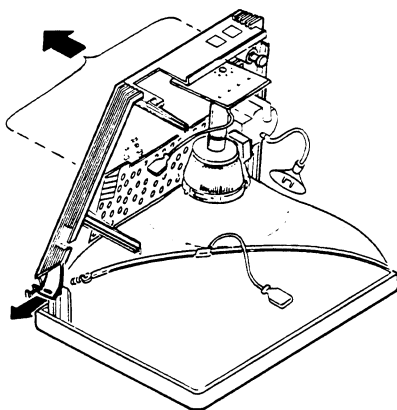

MA 0270 B7

To install the CRT/yoke/bezel assembly, reverse steps 1 through 7.

2.4.1 CRT Disposal (Digital Field Service Only)

This section describes how to safely dispose of the monitor's cathode-ray tube (CRT).

NOTE

This procedure replaces any other tech tips on replacing and disposing of CRTs. This procedure is for Digital personnel only, and is not intended for use by OEM and self-maintenance customers.

CRTs are glass vacuum tubes. Because air pressure outside the tube is greater than air pressure inside, there is always the possibility of accidental implosion.

WARNING

You must handle CRTs very carefully to avoid accidental implosion and shattering glass.

To prevent personal injury from CRT implosion, use the following guidelines and disposal procedure to remove and dispose of a CRT. These guidelines and procedure are Digital field policy for all CRTs more than 3 inches in diameter.

Location

Work in areas where risks and exposure are limited to trained Digital service personnel. Only Digital service personnel should be in the area during CRT removal and replacement.

Protective Gear

Any service person replacing a CRT must wear at least safety goggles and the approved gloves.

Safety goggles	PN 29-16141
Gloves	PN 29-16146

WARNING

To avoid injury to the eyes or hands, always wear goggles and gloves when you work with a CRT.

Handling a CRT

- Never handle the CRT by the neck. Always use two hands and hold the CRT by the sides near its face.
- Keep the CRT away from your body during handling.
- Do not let the neck strike anything.
- Do not rest the CRT on its neck.
- Do not let the CRT touch any tools, such as screwdrivers and soldering irons.

Stocking and Storage

All CRTs must be kept in a closed container or mounted in the device cabinetry.

30 REMOVING AND REPLACING FRUS

CRT Disposal

Use the following procedure to safely dispose of CRTs. Always preform this procedure at a Digital facility.

WARNING

Do not dispose of any CRT until it is rendered inoperative and safe to dispose.

Never perform the following disposal procedure at the customer site. Return the defective CRT to the local Digital facility for disposal.

At the Digital facility you will need

- An area clear of nonessential personnel
- A second person in the area in case of an emergency
- Safety goggles (PN 29-16141)
- Gloves (PN 29-16146)
- Pliers (PN 19-10008)

WARNING

Be careful when performing this procedure. For your safety, you must use the specified gloves and goggles.

Never handle pieces of phosphor coated glass without wearing protective gloves.

1. Place the old CRT and the original packing material in the container from which you removed the new CRT.
2. Seal up the container so that only the very tip of the CRT neck is exposed.
3. Using the specified pliers, slowly crush, but do not snap, the evacuation point. Do not move or disturb the CRT until the hissing sound of inrushing air has stopped.

NOTE

The evacuation point is a protrusion that extends from the circular area defined by the CRT neck pins. The glass protrusion is sometimes encased in a protective plastic cap, and more force is required to crush it.

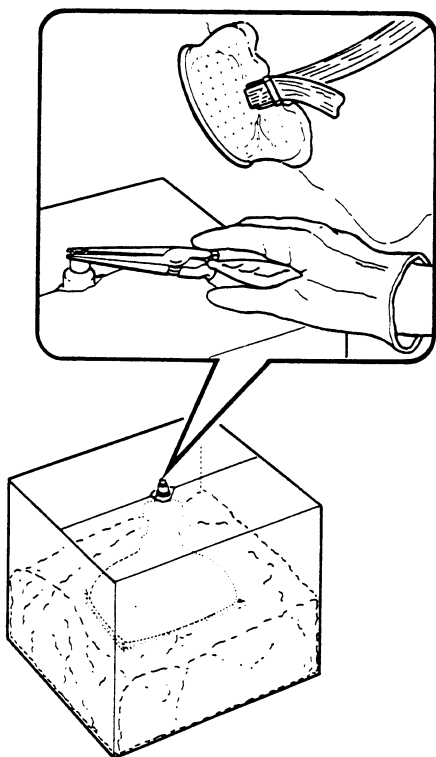

MA-1258-85

4. Seal the carton with packing tape and dispose of it in the Digital site's trash compactor or receptacle.

NOTE

This safe "gassing" of the CRT is necessary to prevent liability and safety problems that may arise from accidental CRT implosion.

32 REMOVING AND REPLACING FRUs

2.5 MONITOR AND LOGIC WITH ARC PROTECTION ASSEMBLY

Remove the monitor and logic with arc protection assembly as follows.

1. Turn off the terminal and unplug the power cord from the wall outlet.
2. Disconnect all cables from the terminal.
3. Remove the access cover (Paragraph 2.2).
4. Remove the CRT/bezel/yoke assembly (Paragraph 2.4).
5. Remove the power supply assembly (Paragraph 2.3).
6. Remove the monitor and logic with arc protection assembly by pressing the plastic tabs located around the edge of the circuit board.

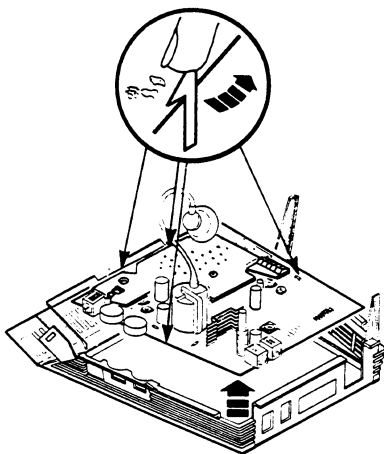

MA-0287-87

- Slide the monitor and logic with arc protection assembly out of the base assembly.

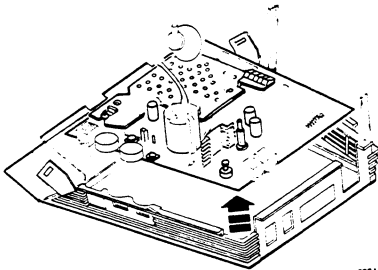

MA 0281 B7

To install the monitor and logic with arc protection assembly, reverse steps 1 through 7.

NOTE

When installing the monitor and logic with arc protection assembly, make sure the jumper at J7 or J8 is set to match the CRT manufacturer — Philips or Clinton. The manufacturer's name is on the label on top of the CRT (Figure 3-1). Place the jumper on J8 (CLIN) for Clinton, or J7 (PHIL) for Philips.

2.6 KEYBOARD

If the keyboard is faulty, replace the keyboard. Disconnect the keyboard cable from the keyboard cable connector on the right side of the terminal.

Install a new keyboard as follows.

- Slide the legend strip under the tabs.

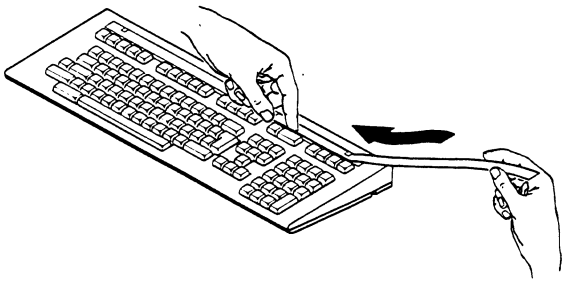

MA-0678-B6

34 REMOVING AND REPLACING FRUs

2. The keyboard cable is already connected to the keyboard and routed to the left. If you want the cable routed to the right, remove the cable from the short groove and press it into the long groove.
3. Insert the other end of the cable into the connector on the right side of the terminal.

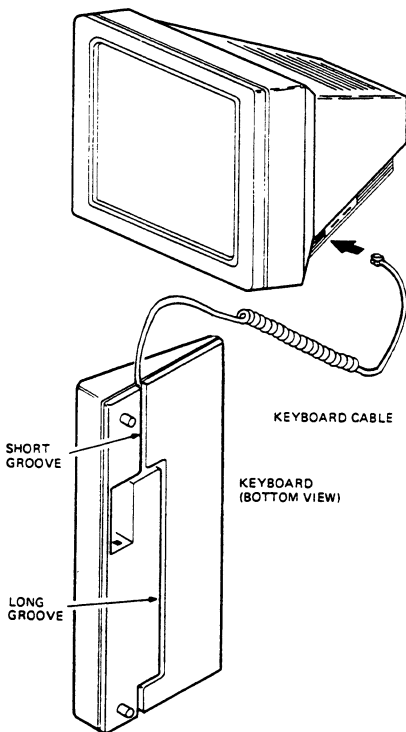

MA-0850-07

3 ALIGNING THE VIDEO MONITOR

3.1 GENERAL

This chapter describes how to align the VT320 monitor. You do not have to perform every adjustment each time you align the monitor. However, you should check all adjustments in the order shown, because many adjustments affect each other. If a setting is already correct, you can skip that adjustment and go on to the next setting.

3.2 MONITOR ADJUSTMENTS

Figure 3-1 shows the location of the controls you use to make adjustments.

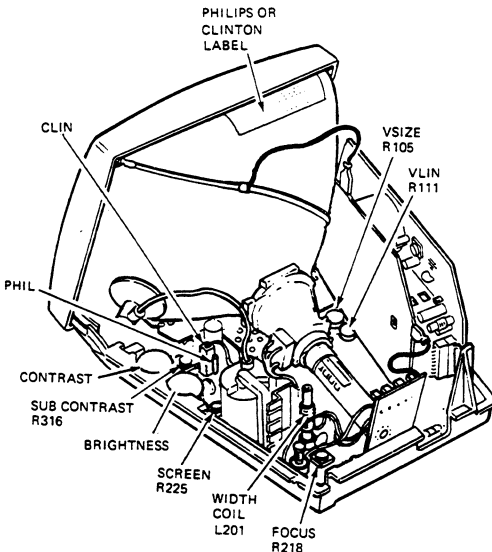

MA-0613-87

Figure 3-1 Monitor Adjustment Controls

3.2.1 Before You Start

Before you perform any adjustments, complete the following steps.

WARNING

The following procedures expose you to high voltages. Use caution when performing them.

1. Remove the access cover (Paragraph 2.2).
2. Reconnect the keyboard cable (Paragraph 2.6) and plug in the power cord.
3. Turn the power switch on (1). Wait for the "VT320 OK" message to appear on the screen.

3.2.2 Displaying the Screen Test Pattern

You use the same test alignment pattern for all monitor adjustments — a screen of E's. To display the pattern, perform the following steps.

1. Wait a moment for the "VT320 OK" message to fully appear.
2. Press Set-Up to display the Set-Up Directory.

NOTE

Use the arrow keys to move the cursor in set-up.

3. Move the cursor to the "On Line " setting. Press Enter to change the setting to "Local".
4. Move the cursor to the General field. Press Enter to display the General Set-Up screen.
5. Move the cursor to the operating mode feature. Use the Enter key to change the setting to "VT100 Mode".

For the horizontal width, vertical height, and centering adjustments, select a reverse video display with no status line as follows.

- a. Move the cursor to the Display field. Press Enter to display the Display Set-Up screen.
 - b. Move the cursor to ___ Text, ___ Screen feature. Press Enter to change the setting to "Dark Text, Light Screen".
 - c. Move the cursor to the ___ Status Display feature. Press Enter to change the setting to "No Status Display".
6. Press Set-Up to leave set-up. Type ESC # 8. Your screen will fill with uppercase E's.

3.2.3 Screen Control

Adjust the screen control as follows.

1. Look at the label on the top of the CRT to determine the manufacturer (Figure 3-1). If the CRT is made by Clinton, place the jumper on J8, labeled CLIN. If the CRT is made by Philips, place the jumper on J7, labeled PHIL.
2. On the right side of the terminal, set the brightness control to maximum and the contrast control to minimum.
3. Adjust the G2 (R225) control until the white background (raster) almost disappears, but is still visible.
4. Readjust the brightness control to the user's preference.

3.2.4 Subcontrast

Adjust the subcontrast control as follows.

1. Set the terminal to "Local" mode and "VT100 Mode", then display the alignment pattern of E's (Paragraph 3.2.2).
2. Set the contrast control on the right side of the terminal to maximum.

38 ALIGNING THE VIDEO MONITOR

3. Turn the brightness control on the right side of the terminal until the raster just disappears.
4. Adjust the SUB CONTRAST control (R316) until the characters are almost blurred, but still in focus.
5. Readjust the contrast control to the user's preference.

3.2.5 Rotation

Adjust the rotation as follows.

WARNING

The next step exposes you to the CRT anode, which stores a high voltage. Use caution when working in this area.

1. Set the terminal to "Local" mode and "VT100 Mode", then display the alignment pattern of E's (Paragraph 3.2.2).
2. Loosen the yoke clamp screw on the CRT neck.
3. Gently rotate the yoke until the display is square and level on the CRT.

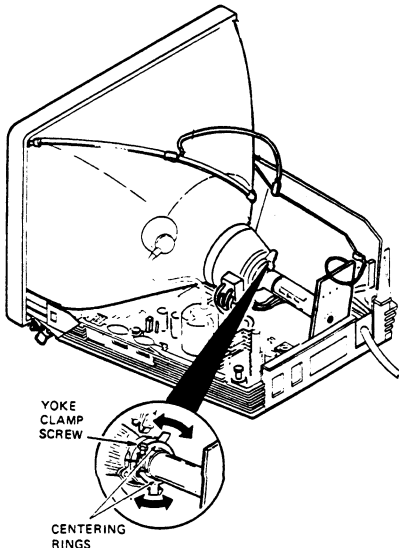

MA 0306-87

Figure 3-2 Rotation and Centering Adjustments

CAUTION

Make sure you take up the slack on the CRT clamp before you tighten the screw. Do not overtighten, or you may crack the CRT neck.

4. Tighten the screw on the CRT connector clamp.

3.2.6 Horizontal Width

Check and adjust the horizontal width as follows. You need a metric measuring tape (PN 29-25342).

1. Set the terminal to "Local" mode, "VT100 Mode", "Dark Text, Light Screen", and "No Status Display". Then display the alignment pattern of E's (Paragraph 3.2.2).
2. Use your metric measuring tape to measure the width of the reverse video pattern of E's.
3. If the pattern does not measure about 225 mm, use the tuning wand tool (PN 29-26128-00) to adjust the WIDTH (L201) control.

3.2.7 Vertical Height

Check and adjust the vertical height as follows.

1. Set the terminal to "Local" mode, "VT100 Mode", "Dark Text, Light Screen", and "No Status Display". Then display the alignment pattern of E's (Paragraph 3.2.2).
2. Use your metric measuring tape to measure the height of the reverse video pattern of E's. If the pattern does not measure about 160 mm, use the tuning wand tool to adjust the V SIZE control (R105).
3. If necessary, readjust the vertical linearity (Paragraph 3.2.8).

3.2.8 Vertical Linearity

Check and adjust the vertical linearity as follows.

1. Set the terminal to "Local" mode and "VT100 Mode", then display the alignment pattern of E's (Paragraph 3.2.2).
2. Check the height of the E characters on the top and bottom row of the display. All characters should appear to be the same size.

40 ALIGNING THE VIDEO MONITOR

3. If necessary, use the tuning wand tool to adjust adjust the V LIN control (R111) until all characters are the same height.

3.2.9 Centering

Check and adjust the centering of the screen display as follows.

1. Set the terminal to "Local" mode, "VT100 Mode", "Dark Text, Light Screen", and "No Status Display". Then display the alignment pattern of E's (Paragraph 3.2.2).
2. Make sure you have completed the adjustments for the screen control, subcontrast, rotation, horizontal width, vertical height, and vertical linearity, if they are needed.
3. Check that the reverse video pattern of E's is centered within the CRT bezel.
4. If necessary, use the centering rings on the neck of the CRT to center the reverse video pattern within the CRT bezel (Figure 3-2).

3.2.10 Focus

Check and adjust the focus as follows.

1. Set the terminal to "Local" mode and "VT100 Mode", then display the alignment pattern of E's (Paragraph 3.2.2).
2. Check the E characters at the four corners and at the center of the screen. You should be able to see the individual dots in the vertical segments of each E.

NOTE

Make sure the screen is clean. This condition can appear to affect the focus.

3. Adjust the FOCUS control (R218) so that you can see each character clearly and distinctly.

4 USING SET-UP

4.1 GENERAL

The VT320 terminal has a set-up utility that lets you change the settings of operating features from the keyboard. This chapter provides a brief summary of how to use set-up. Chapter 4 of *Installing and Using the VT320 Video Terminal* describes the set-up utility in detail.

The set-up utility is a series of display screens. Each screen lists a group of related features, such as communications or display features. You can move from screen to screen in set-up.

4.2 DISPLAYING SET-UP SCREENS

To enter or leave set-up, you press the Set-Up (F3) key on the top row of the VT320 keyboard. When you enter set-up, the Set-Up Directory appears (Figure 4-1).

You can select any set-up screen from the Set-Up Directory. Use the arrow keys to move the cursor to the name of the set-up screen. Press **Enter** to display that screen.

International

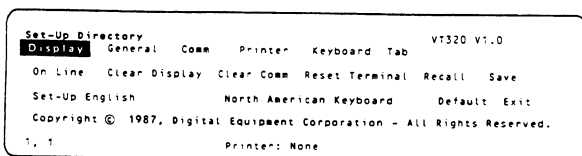

MA 029087

North American

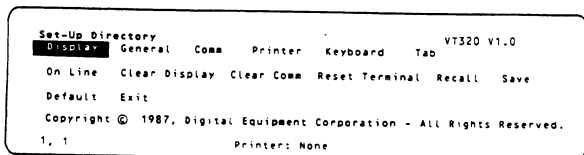

MA 0300 87

Figure 4-1 Set-Up Directory

4.3 CHANGING SETTINGS

You use the arrow keys to move to different fields in each set-up screen. The cursor highlights the selected field in reverse video.

Some set-up features are actions fields. Others are parameter fields with two or more possible settings. You use the **Enter** key to perform actions or change set-up settings.

Action fields Move the cursor to the desired field. Then press **Enter** to have the terminal perform the action.

Parameter fields Move the cursor to the desired field. Then use **Enter** to step through the values for the feature. When the desired value appears, move to a new field (or leave set-up) to select that value.

4.4 SAVING SET-UP VALUES

You may want to save the current settings in set-up before you run tests. Check with the user. When you save settings, you can recall them later. You can save the current set-up settings as follows.

1. Press **Set-Up** to enter Set-Up. The Set-Up Directory appears.
2. Use the arrow keys to move to the **Save** field.
3. Press **Enter** to save the current settings in all set-up screens.

The **Save** feature stores the current values of the set-up features. The terminal uses these values until you change them.

4.5 RECALLING SET-UP VALUES

You can reset the terminal to a previous set of set-up values. There are two types of set-up values you can recall. Check with the user to see which settings were in use.

- Factory-default settings
- Saved settings (selected by the user)

You can recall set-up values as follows.

1. Press **Set-Up** to enter set-up. The Set-Up Directory appears.
2. *To select factory-default settings* : Move the cursor to the **Default** field and press **Enter**.
To select saved settings : Move the cursor to the **Recall** field and press **Enter**.

A OPTIONS AND DOCUMENTATION

You can order the following options and manuals from Digital for the VT320.

OPTIONS

Tilt-Swivel Base

Part Number	Description
VT3XX-CA	Lets the user adjust the viewing angle of the terminal.

Modems

Part Number	Description
DF02-AA	AT&T 103J equivalent. 300 baud, full-duplex modem with EIA RS232-C interface
DF03-AA	Direct-connect. AT&T 103J/212A equivalent. 300/1200 baud. full-duplex modem with RS232 interface
DF224-AA	Direct-connect. AT&T 103J/212A equivalent. 2400 baud, full-duplex modem with RS232 interface

Cables

Part Number	Length	Connector
Printer Cables and Adapter (VT320 to printer)		
BC16E-10	10 ft (3 m)	6-pin M DEC-423 to
BC16E-25	25 ft (7.6 m)	6-pin M DEC-423
H8751-A (12-23599-01)	adapter	25-pin M to 6-pin F DEC-423

Extension Cables

BC22E-10	10 ft (3 m)	25-pin F RS232 to
BC22E-25	25 ft (7.6 m)	25-pin M RS232

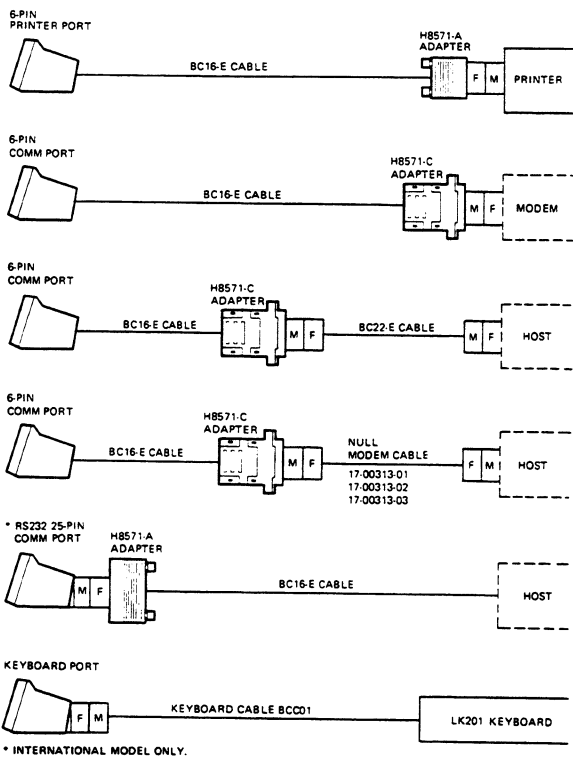

Figure A-1 VT320 Cables

Null Modem Cables

17-00313-01	10 ft (3 m)	25-pin F RS232 to
17-00313-02	25 ft (7.6 m)	25-pin F RS232
17-00313-03	50 ft (15.2 m)	

Communication Cables and Adapters

BC16E-10	10 ft (3 m)	6-pin M DEC-423 to
BC16E-25	25 ft (7.6 m)	6-pin M DEC-423
H8571-C	adapter	25-pin F RS232 to
(12-23599-04)		6-pin M DEC-423
H8571-F	adapter	
(12-28172-01)		

46 A: OPTIONS AND DOCUMENTATION

Keyboard Cable

BCC01-06 6 ft (1.8 m) Telephone jack
(17-00294-00)

AC Power

Cable

Country

17-00198-09	Australia, New Zealand
17-00199-14	Austria, Belgium, Finland, France Germany, Netherlands, Norway, Sweden
17-00606-10	Canada, Japan, Mexico, USA
17-00310-08	Denmark India, South Africa
17-00209-10	Ireland, United Kingdom Israel
17-00364-10	Italy
17-00210-07	Switzerland

RELATED DOCUMENTATION

You can order the following VT320 documents from Digital.

Installing and Using the VT320 Video Terminal
Provides users with the information needed to install, operate, and maintain the VT320 terminal. Also provides a summary of programming control functions. There are two versions of this manual.

North American Model	EK-VT320-UG
International Model	EK-VT320-UU

VT320 Programmer Reference Manual **EK-VT320-RM**

Provide information on character processing, character codes, and control functions available for VT320 applications.

VT320 Video Terminal IPB **EK-VT320-IP**

Provides a detailed parts breakdown of the terminal's field replaceable units. Does not provide part numbers for printed circuit board components.

VT320 Family Field Maintenance Print Set **MP-02509-01**

Provides a complete set of VT320 electrical and mechanical schematic diagrams.

B VT320 MODELS AND RECOMMENDED SPARES

This appendix has two sections. "VT320 Models" lists the available models of the VT320 video terminal. "Recommended Spares" lists the spare components that a field service technician should have when servicing a VT320 video terminal.

VT320 MODELS

The VT320 comes in two basic models, North American and international.

Model Number	Screen Color	Power Requirement
-------------------------	-------------------------	------------------------------

North American Terminals

VT320-A2	White	120V
VT320-B2	Green	120V
VT320-C2	Amber	120V

International Terminals

VT320-A3	White	240V
VT320-G2	White	120V
VT320-B3	Green	240V
VT320-H2	Green	120V
VT320-C3	Amber	240V
VT320-J2	Amber	120V

RECOMMENDED SPARES

The following is the recommended spares list for the VT320.

48 B: VT320 MODELS AND RECOMMENDED SPARES

VT320 Recommended Spares List

Spares	Part Number
Assemblies	
Access cover	70-24242-01
Bottom assembly	70-24245-01
CRT/bezel/yoke	
Amber	70-24240-03
Green	70-24240-02
Paper white	70-24240-01
Monitor and logic with arc protection	
North American	70-24577-01
International	70-24577-02
Power supply	
North American	70-24244-01
International	70-24244-02
Loopback connectors	
DEC-423 port	12-25083-01
RS232 port	12-15336-00
Keyboards	
Danish	LK201-RD
Dutch	LK201-NH
Finnish	LK201-NX
Flemish	LK201-LB
French/Belgian	LK201-LP
French Canadian	LK201-LC
German/Austrian	LK201-NG
Italian	LK201-LI
North American/United Kingdom	LK201-RE
North American/United Kingdom	LK201-PE
WPS	
Norwegian	LK201-RN
Portugese	LK201-LV
Spanish	LK201-LS
Swedish	LK201-NM
Swiss (French)	LK201-LK
Swiss (German)	LK201-LL

C PHYSICAL/FUNCTIONAL DIAGRAMS

Figure C-1 shows the components of the North American model of the VT320 video terminal.

Figure C-2 shows the components of the international model of the VT320 video terminal.

Monitor and Logic with Arc Protection Assembly

J2 Keyboard Connector

Pin 1	KBTXD	Transmitted data
2	GND	Ground
3	+12 V	
4	KBRXD	Received data

J3 DEC-423 Comm Connector

Pin 1	DTR	Data terminal ready
2	TXD	Transmitted data
3	GND	Ground
4	GND	Receive ground
5	HRXD	Received data
6	HDSR	Data set ready

J5 Printer Port Connector

Pin 1	PTRDTR (+5 V)	Data terminal ready
2	PTRTXD	Transmitted data
3	GND	Ground
4	GND	Receive ground
5	PTRRXD	Received data
6	PTRDSR	Data set ready

J102 CRT Yoke Connector

Pin 1	Vertical yoke	Yellow
2	Vertical yoke	Brown
3	Hor yoke	White
4	Hor yoke	Red

P8 CRT Select Jumper

J8	CLIN	Clinton CRT select
J7	PHIL	Philips CRT select

J701 CRT Socket Connector

Pin 1	GRNG1	Grid 1 (green)
2	YELK	Cathode (yellow)
3	BRNH1	Heater -12 V (brown)
4	P701 (H2)	Heater ground (black)
5	Not used	
6	REDG2	Grid 2 (red)
7	BLUG4	Grid 4 (blue)

Power Supply

J502 Power Supply Connector

Pin 1	+12 V	
2	GND	Ground
3	GND	Ground
4	+5 V	
5	N/C	No connection
6	GND	Ground
7	18.5 V	

Power Supply AC Input

P4	Phase
P5	Neutral

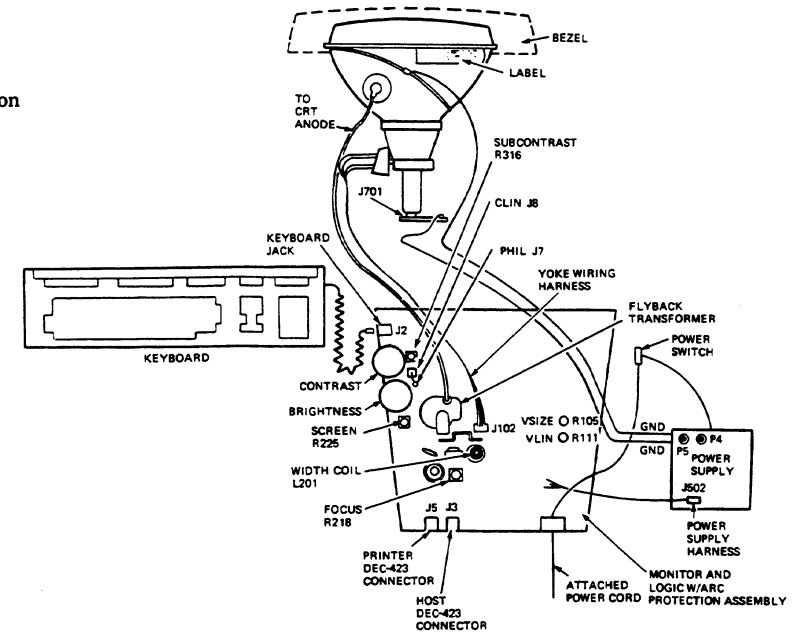

Figure C-1 North American Model

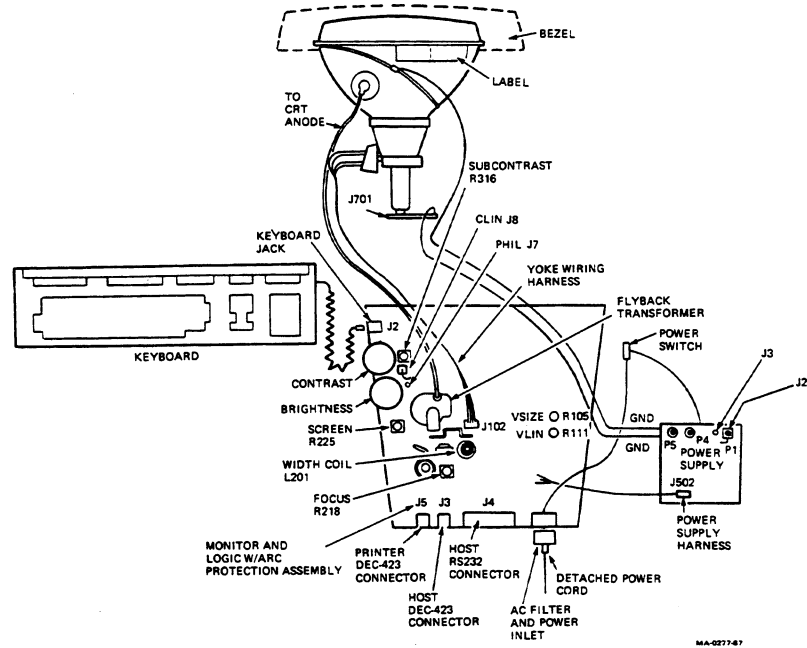

Figure C-2 International Model

Monitor and Logic with Arc Protection Assembly

J2 Keyboard Connector

Pin 1	KBTXD	Transmitted data
2	GND	Ground
3	+12 V	
4	KBRXD	Received data

J3 DEC-423 Comm Port

Pin 1	HDTR2	Data terminal ready
2	HTXD2	Transmitted data
3	GND	Transmit ground
4	HCOM	Receive ground
5	HRXD2	Received data
6	HDSR2	Data set ready

J4 RS232 Comm Port EIA 25-Pin Comm1 Connector

Pin 1	GND	Ground
2	TXD	Transmitted data
3	RXD	Received data
4	RTS	Request to send
5	CTS	Clear to send
6	DSR	Data set ready
7	SIG GND	Signal ground
8	CDL	Carrier detect
9	Not used	
10	Not used	
11	Not used	
12	SPDI	Speed indicator
13	Not used	
14	Not used	
15	Not used	
16	Not used	
17	Not used	
18	Not used	
19	Not used	
20	DTR	Data terminal ready
21	Not used	
22	Not used	
23	SPDS	Speed select
24	Not used	
25	Not used	

J5 Printer Port Connector

Pin 1	PTRDTR (+5 V)	Data terminal ready
2	PTRTXD	Transmitted data
3	GND	Ground
4	PTRCOM	Receive ground
5	PTRRXD	Received data
6	PTRDSR	Data set ready

J102 CRT Yoke Connector

Pin 1	Vert yoke	Yellow
2	Vert yoke	Brown
3	Hor yoke	White
4	Hor yoke	Red

J701 CRT Socket Connector

Pin 1	GRNG1	Grid 1 (green)
2	YELK	Cathode (yellow)
3	BRNH1	Heater -12 V (brown)
4	P701 (H2)	Heater ground (black)
5	Not used	
6	REDG2	Grid 2 (red)
7	BLUG4	Grid 4 (blue)

Power Supply Assembly

J502 Power Supply Connector

Pin 1	+12 V	
2	GND	Ground
3	N/C	Not connected
4	+5 V	
5	GND	Ground
6	GND	Ground
7	18.5 V	

P1 Voltage Select Jumper

J2	120 V select
J3	240 V select

Power Supply AC Input

P4	Phase
P5	Neutral

**TECHNICAL DOCUMENTATION
CHANGE NOTICE**

This notice contains changes to the *VT320 Pocket Service Guide* (EK-VT320-PS). Update your manual as indicated.

Page 25

Add the following note before step 2.

NOTE

Some VT320 terminals contain an arc protection logic board as illustrated. Other VT320 terminals have the arc protection circuitry self contained in the CRT socket. These terminals do not correspond with the illustrations in this manual.

Page 47

Replace Appendix B in the manual with the following revised Appendix B.

B

VT320 Models and Recommended Spares

This appendix has two sections. "VT320 Models" lists the available models of the VT320 video terminal. "Recommended Spares" lists the spare components that a field service technician should have when servicing a VT320 video terminal.

B.1 VT320 MODELS

The VT320 comes in three basic models: North American, international, and custom.

B-2 VT320 Models and Recommended Spares

Table B-1 VT320 Models

Model Number	Screen Color	Power Requirement	Comment
North American Terminals			
VT320-A2	White	120 V	USA, Canada
VT320-B2	Green	120 V	USA, Canada
VT320-C2	Amber	120 V	USA, Canada
International Terminals			
VT320-A3	White	240 V	Europe, Asia
VT320-G2	White	120 V	USA, Canada
VT320-B3	Green	240 V	Europe, Asia
VT320-H2	Green	120 V	USA, Canada
VT320-C3	Amber	240 V	Europe, Asia
VT320-J2	Amber	120 V	USA, Canada
Custom Terminals			
VT320-A5	White	240 V	Australia, New Zealand
VT320-B5	Green	240 V	Australia, New Zealand
VT320-C5	Amber	240 V	Australia, New Zealand
VT320-62	Green	120 V	CSS, Arabia
VT320-63	Green	240 V	CSS, Arabia

Table B-1 (Cont.) VT320 Models

Model Number	Screen Color	Power Requirement	Comment
VT320-L2	Green	120 V	CSS, expanded memory
VT320-L3	Green	240 V	CSS, expanded memory
VT320-X2	Amber	120 V	CSS, USA, Canada
VT320-A6	White	240 V	Scandinavian countries

B.2 Recommended Spares

The following is the recommended spares list for the VT320.

Table B-2 VT320 Recommended Spares List

Spares	Part Number	Model Number
Assemblies		
Access cover	70-24242-01	All models
Bottom assembly	70-24245-01	All models
CRT/Bezel/Yoke		
White	70-24240-01	VT320- A2/A3/G2
Green	70-24240-02	VT320- B2/B3/H2
Amber	70-24240-03	VT320- C2/C3/J2
White	70-24240-04	VT320-A5

B-4 VT320 Models and Recommended Spares

Table B-2 (Cont.) VT320 Recommended Spares List

Spares	Part Number	Model Number
Green	70-24240-05	VT320-B5
Amber	70-24240-06	VT320-C5
White	70-24240-07	VT320-A6
Monitor and logic with arc protection		
North American	70-24577-01	VT320-A2/B2/C2
International	70-24577-02	VT320-A3/B3/C3/A5 VT320-B5/C5/G2/H2/J2
Custom models		
	70-24577-03	VT320-62/63
	70-24577-04	VT320-L2/L3
	70-24577-05	VT320-X2
	70-24577-06	VT320-A6
Power supply		
North American	70-24244-01	VT320-A2/B2/C2
International	70-24244-02	VT320-A3/B3/C3/A5 VT320-B5/C5/G2/H2/J2
Loopback connectors		
DEC-423 port	12-25083-01	All models
RS232 port	12-15336-00	All models
Keyboards		
Danish	LK201-RD	

Table B-2 (Cont.) VT320 Recommended Spares List

Spares	Part Number	Model Number
Dutch	LK201-NH	
Finnish	LK201-NX	
Flemish	LK201-LB	
French/Belgian	LK201-LP	
French/Canadian	LK201-LC	
German/Austrian	LK201-NG	
Italian	LK201-LI	
North American/United Kingdom	LK201-RE	
North American/United Kingdom	LK201-PE	
WPS		
Norwegian	LK201-RN	
Portugese	LK201-LV	
Spanish	LK201-LS	
Swedish	LK201-NM	
Swiss (French)	LK201-LK	
Swiss (German)	LK201-LL	

Copyright ©1989
 by Digital Equipment Corporation
 All rights reserved.