



## ***Compaq AlphaServer DS10 Systems***

Technical Summary



# Contents

- 1**  
**System Overview**  
**Features and Benefits**
- 2**  
**Third-Generation Alpha Chip**  
Chip Operation  
Alpha 21264 Features
- 3**  
**Architecture**  
System Block Diagram
- 4**  
**System Board**  
Component and Connector Locations
- 5**  
**Memory**  
Memory Options  
Memory Configuration  
Memory Performance Considerations
- 6**  
**System I/O**  
Block Diagram of I/O Control  
PCI Slots  
I/O Ports
- 7**  
**Storage**  
RAID (Redundant Array of Independent Disks)  
**System Control**  
Control Panel
- 8**  
**Server Management**  
Operational Management  
Platform Management  
Error Reporting  
**Security**  
**Reliability and Availability Features**  
Processor Features  
Memory Features  
I/O Features  
System Features
- 9**  
**Clustering**  
PCI to Memory Channel Interconnect  
Operating System Support  
**Performance**  
Sources of Performance Information  
Information for Compaq Partners
- 10**  
**Service and Support**  
Hardware Warranty  
Software Warranty
- 11**  
**Compaq AlphaServer DS10 System Diagrams**
- 12**  
**System Features at a Glance**
- 13**  
**Physical Characteristics**

# Compaq AlphaServer DS10 Systems

The *Compaq AlphaServer DS10* system is an entry-level system offering 64-bit computing with the Alpha processor. This single processor system is ideal for ISP/Internet applications, telecom applications, software development, and replicated site applications. The 3-U system box can be mounted in a cabinet or used on a desktop.

*Compaq AlphaServer* products use the 64-bit Alpha RISC architecture that supports multiple operating systems: *Tru64 UNIX*, *OpenVMS*, and Linux.

## System Overview

The *Compaq AlphaServer DS10* systems are now available with the 600 MHz Alpha chip, the 21264A (marketed as 600 MHz but it actually runs at 616 MHz). Systems with the 466 MHz 21264 Alpha chip are also being offered. Memory begins at 256 Mbytes and can be increased to 2 Gbytes. Second-level cache is 2 Mbytes. The switch-based system interconnect exploits the full potential of the Alpha chip.

The system measures 17 x 19 x 5 inches (3U) and can be placed on a desktop or rackmounted in a choice of three M-series cabinets, along with additional disks. In the largest cabinet (79 inches) up to 12 systems can be installed, or if more storage is desired, there can be up to 6 StorageWorks shelves and up to 8 systems. A rackmount slide kit is included with each system.

Six drive bays are available for storage devices. Each system includes a CD-ROM and floppy; a 5.25-inch removable media device can be added. With four 1-inch disks, there can be 145 GB of storage in the system box.

There are four full-length PCI slots: three 64-bit slots and one 32-bit slot. Integrated on the system board are two 10/100 Mbit fast Ethernet controllers, an IDE controller, two serial ports, one parallel port, remote management console, and keyboard and mouse ports.

Systems can be purchased with the *Tru64 UNIX* or *OpenVMS* operating systems installed. Or they can be purchased without any operating system, allowing customers to install Linux.

For more information on *Compaq AlphaServer DS10* systems, see

<http://www.compaq.com/alphaserver/servers.html>

## Features and Benefits

- **Performance**

The Alpha chip, the world's fastest microprocessor, is offered with a switch-based interconnect that supports one processor (466 MHz or 600 MHz) and up to 2 Gbytes of memory. This switch-based system provides a memory bandwidth of up to 1.3 Gbytes/sec (peak) using a 128-bit memory bus running at 77 MHz. The peak I/O bandwidth is 250 Mbytes/sec.

- **Multiple Operating Systems**

No other server offers the flexibility of running so many operating systems: *Tru64 UNIX*, *OpenVMS*, and Linux. It's ideal as a development tool as well as a Web server or file server, or for remote applications or E-commerce applications.

- **Package and Price**

All the features of *AlphaServers* are now available in a package that goes anywhere at a price attractive to everyone. Start with one and then add to your base as your needs demand. Use the DS10 as a dedicated system or set up a cluster.

- **DS10 Workstations**

The 600 MHz system is also offered as a workstation and is called the *AlphaStation DS10*.

## Third-Generation Alpha Chip

The third generation of the Alpha microprocessor, the Alpha 21264, is a superscalar, superpipelined implementation of the Alpha architecture. The first offering of this chip, which was manufactured using the CMOS-6 process, was known as EV6 and now the EV67 (21264A) chip is available, which uses the CMOS-7 process. Over 15.2 million transistors are on one die.

In our discussion here, the Alpha 21264 designation applies to the EV6 and the EV67 chips, unless we need to distinguish between the two. Designed for performance, the Alpha 21264 achieves this goal by carefully studied and simulated architectural and circuit analysis. The 21264 memory system also enables the high performance levels. On-chip and off-chip caches provide for very low latency data access, which allows for very high bandwidth data access. The 21264 2-Mbyte off-chip cache runs at 186 MHz; the 21264A 2-Mbyte off-chip cache runs at 205 MHz.

Internal to each chip is a 64-Kbyte instruction cache (I-cache) and a 64-Kbyte data cache (D-cache).

- **I-cache.** 64 Kbytes, two-way set-associative, virtually addressed cache with 64-byte blocks
- **D-cache.** 64 Kbytes, two-way set-associative, virtually indexed, physically tagged, writeback cache with 64-byte blocks

### Chip Operation

Several key design choices were made in the chip architecture to maximize performance: Four instructions are fetched each cycle, and then how those instructions are handled boosts the speed of execution. Register renaming assigns a unique storage location with each write reference to a register, avoiding register dependencies that can be a potential bottleneck to processor performance.

Another design feature, out-of-order execution, permits instructions to execute in an order different from the order that the instructions are fetched. In effect, instructions execute as soon as possible. This allows for faster execution since critical path computations are started and completed as soon as possible.

In addition, the Alpha 21264 employs speculative execution to maximize performance. It speculatively fetches and executes instructions even though it may not know immediately whether the instruction will be on the final execution path. This is particularly useful, for instance, when the 21264 predicts branch directions and speculatively executes down the predicted path. The sophisticated branch prediction in the 21264 coupled with the speculative and dynamic execution extracts the most instruction parallelism from applications.

For more information about the chip, see <http://www.compaq.com/alphaserver/download/ev6chip.pdf>

### Alpha 21264 Features

- Out-of-order instruction execution
- Large (64 Kbyte) on-chip data and instruction caches
- Improved branch prediction through intuitive execution
- Register renaming
- Increased bandwidth for high-speed access to second-level cache and system memory
- Motion video instructions
- Square root and divide instructions
- All instructions are 32 bits long and have a regular instruction format
- Floating-point unit, supports DIGITAL and IEEE floating-point data types
- 80 integer registers, 64 bits wide
- 72 floating-point registers, 64 bits wide

## Architecture

The traditional bus interconnect has been replaced by a switch-based interconnect system. With a bus design, the processors, memory, and I/O modules share the bus. As the number of bus users increases, the transactions interfere with one another, increasing latency and decreasing aggregate bandwidth. However, with a switch-based system there is no degradation in performance as the number of CPUs, memory, and I/O users increase. Although the users increase, the speed is maintained.

With a switch-based, or point-to-point interconnect, the performance remains constant, even though the number of transactions multiplies. The switched system interconnect uses a set of complex chips that route the traffic over multiple paths.

The chipset consists of one C-chip, one P-chip, and two D-chips.

- **C-chip.** Provides the command interface from the CPU.
- **D-chips.** Provide the data path for the CPU, main memory, and I/O.
- **P-chip.** Provides the interface to the PCI bus.

This chipset, similar to those used in the *AlphaServer DS20* and *ES40* systems, supports up to one CPU and up to 2 Gbytes memory. Interleaving occurs when at least two memory arrays are used.

The PAD bus, the interface between the P-chip and the D-chips, is 32 data bits with 4 check bits. The 128-bit memory bus supports two memory arrays, yielding a 1.3 Gbyte/sec system bandwidth. Transactions are ECC protected. Upon the receipt of data, the receiver checks for data integrity and corrects any errors.

**System Block Diagram**

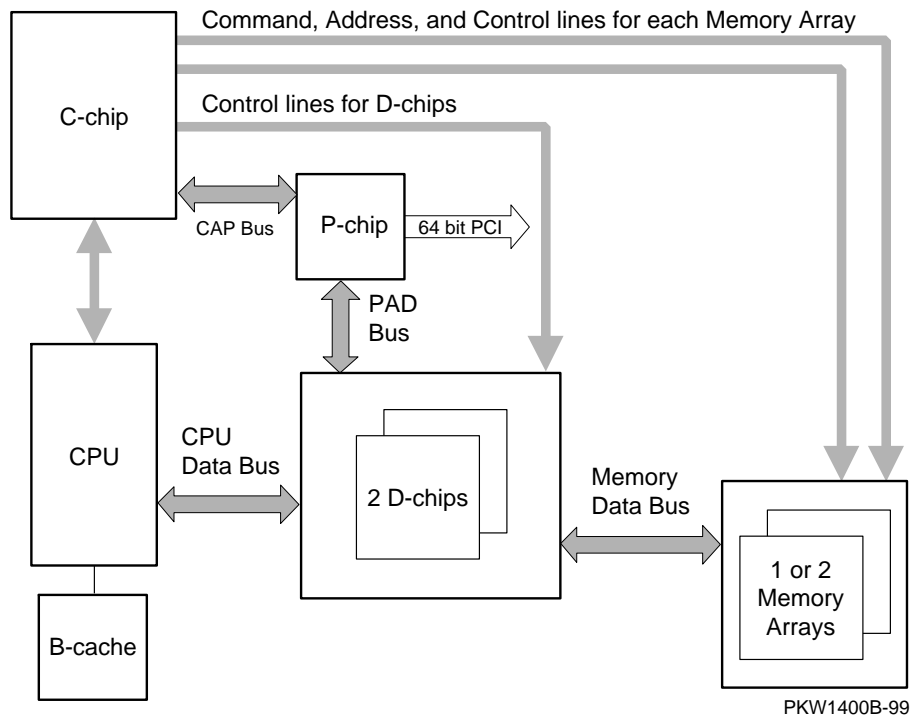

## System Board

The interconnect switch is implemented on the system board by the chipset consisting of one C-chip, one P-chip, and two D-chips. The chipset provides the data and address path between the CPU, memory, and the I/O subsystem.

The CPU installed on the system board is either the Alpha 21264 (466 MHz) or the Alpha 21264A (600 MHz). The four cache chips provide 2 Mbytes of second-level cache. A flash ROM holds the SRM console code, the AlphaBIOS console code, and the NVRAM data. The remote management console (RMC) is implemented by the RMC processor and is accessed

through the COM1 port. Integrated into the system board is the logic needed for all the ports shown on the left side of the module, including the two Ethernet ports, and also for the two IDE connectors.

Jumpers on the board allow you to change the action of the Halt button and disable the RMC timer.

Connectors are on the system board for five other cards: the PCI riser card and four memory DIMMs.

### Component and Connector Locations

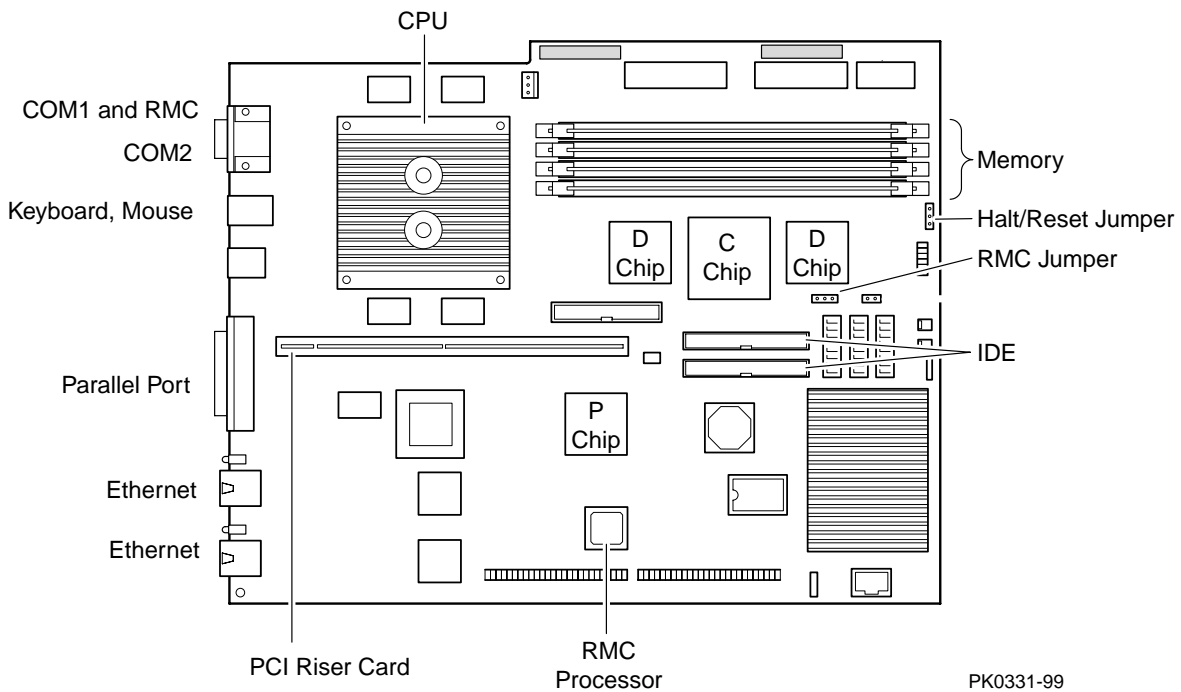

## Memory

Memory throughput is maximized by the following features:

- 128-bit wide memory data bus
- Very low memory latency (120 ns) and high bandwidth with 12 ns clock
- ECC memory

The switch interconnect can move a large amount of data over the memory data bus. The data bus is 128 bits wide (16 bytes). With the memory bus speed of 77 MHz, the maximum bandwidth is 1.3 GB/sec.

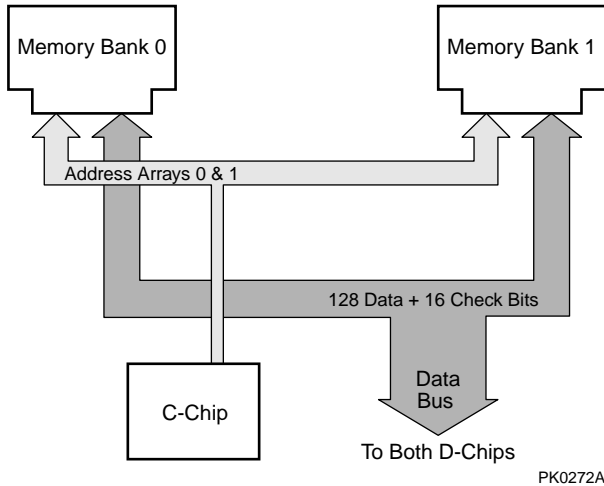

## Memory Options

Each memory option consists of two 200-pin industry-standard DIMMs. The DIMMs are synchronous DRAMs. Memory options are available in the following sizes:

- 128 Mbytes (64 MB DIMMs)
- 256 Mbytes (128 MB DIMMs)
- 512 Mbytes (256 MB DIMMs)
- 1 Gbyte (512 MB DIMMs)

The system supports 2 Gbytes of memory.

## Memory Configuration

- Systems come with one memory option (two DIMMs) installed in Bank 0.
- Both DIMMs in a bank must be the same type and size.
- A second set of DIMMs can be added.

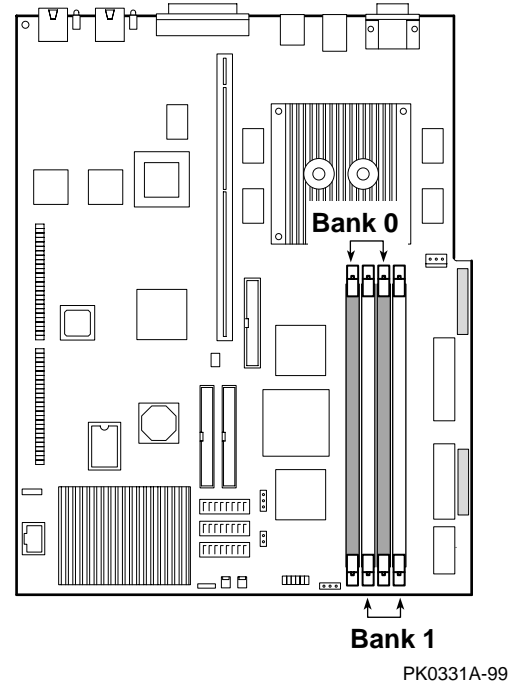

## Memory Performance Considerations

With one memory option (2 DIMMs), memory operation interleaving will not occur. With two memory options (4 DIMMs), memory read-write operations are two-way interleaved. Interleaved operations reduce the average latency and increase the memory throughput over noninterleaved operations.

## System I/O

The industry-standard PCI bus is the number one choice for high-performance I/O options, such as disk storage and high-performance video applications.

The PCI bus implementation has the following characteristics:

- Fully compliant with the PCI Version 2.1 Specification
- Operates at 31 MHz, delivering a peak bandwidth of 250 Mbytes/sec.

- Supports three address spaces: PCI I/O, PCI memory, and PCI configuration space
- Supports byte/word, tri-byte, and longword operations
- Exists in noncached address space only

### Block Diagram of I/O Control

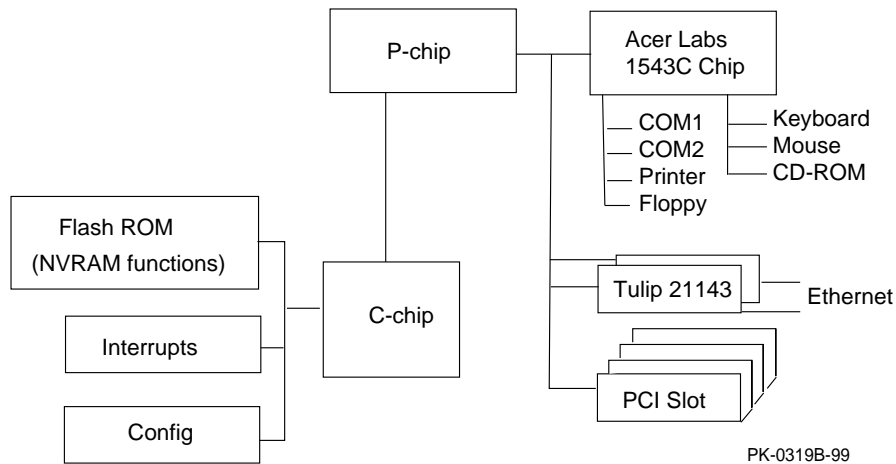

The industry-standard PCI I/O bus allows you to use inexpensive, widely available I/O options. Both 32-bit and 64-bit PCI options can be used; 3.3V and 5V options are supported.

The Acer Labs 1543C chip provides the bridge from the PCI to lower level bus functions. The C-chip controls accesses to memory on behalf of the P-chip. Two Tulip chips provide control for the two integrated Ethernet ports. On the PCI riser card are four PCI slots; three 64-bit slots and one 32-bit slot, which can be used for a video controller.

### PCI Slots

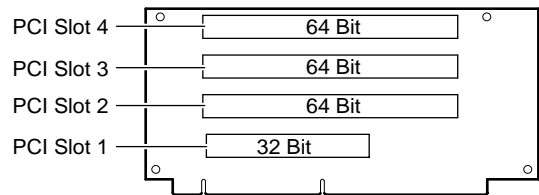

### I/O Ports

At the rear of the system are connectors offering access to two serial communication ports, one parallel port, two Ethernet ports, and ports for the keyboard and mouse. (The USB ports are not supported.) The COM1 port is used for the system console and for the remote management console.

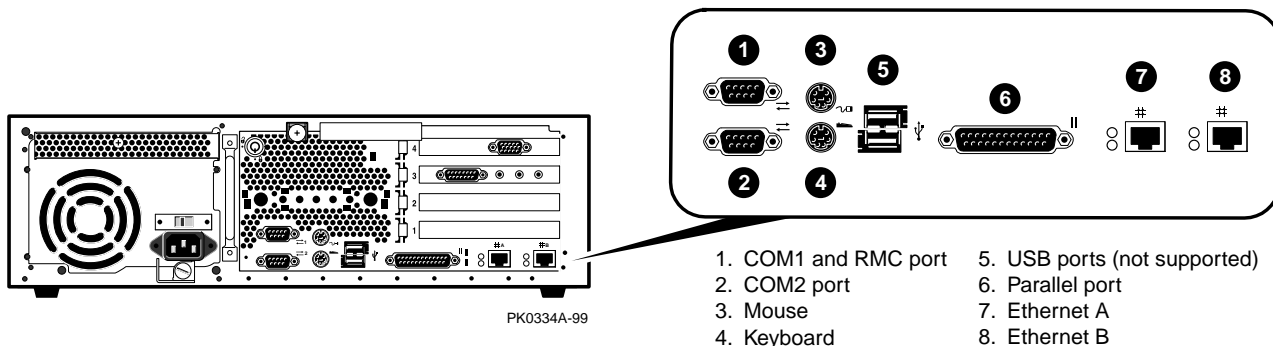



## Storage

The DS10 system has six drive bays. In addition to the floppy diskette drive, CD-ROM drive, and system disk, three other devices can be installed.

A tape drive (5.25 inch x 1.6 inch) can be installed under the CD-ROM. Or if another disk is desired, this space holds a 3.5 inch x 1 inch hard drive. Another disk can be installed under the floppy and another above the power supply. Refer to the table and figure to see what can be placed in these locations.

Disks supported are 10, 27, and 30 GB IDE disks and 9.1, 18.2, and 36.4 GB UltraSCSI disks.

Location	Description	Size, Watts
①	Floppy diskette	
②	Hard disk	3.5 x 1 inch
③	CD-ROM	1.6 inch
④	Tape drive or hard disk	5.25 x 1.6 inch removable media or 3.5 x 1 inch hard disk
⑤	System disk	3.5 x 1 inch hard disk
⑥	Hard disk	3.5 x 1 inch; less than 12 watts

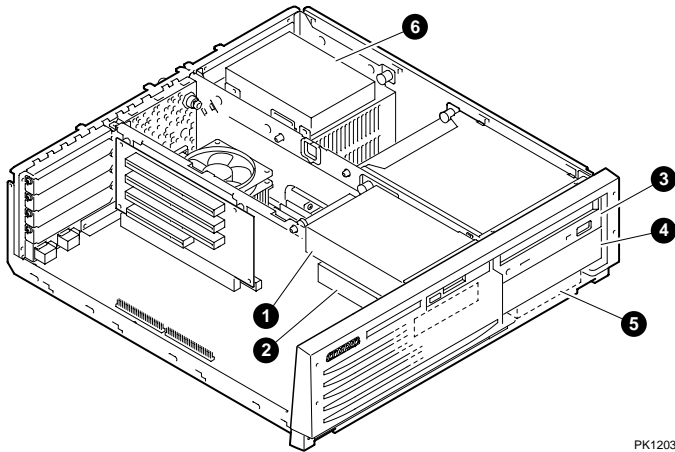

PK1203

## RAID (Redundant Array of Independent Disks)

The system can be configured with optional PCI RAID controllers to organize disk data cost-effectively, improve performance, and provide high levels of storage integrity. Today, RAID is only available with StorageWorks shelves.

The optional RAID controllers have the following features:

- Support for hot-swap drives
- Automatic rebuild after hot swap
- Console support for booting system from RAID
- RAID levels 0, 1, 0+1, 5
- Optional write cache
- Optional read cache
- Support for command queuing

## System Control

Close monitoring and control of the system environment and hardware is done by the remote management console (RMC). This logic allows the system operator to perform console operations remotely using a dial-in modem. The RMC logic is implemented using a PIC17C44 microprocessor on the system board. The RMC firmware code resides on the microprocessor and in flash memory. The RMC is powered by an auxiliary 5V supply, so even when the system is powered off at the control panel the RMC can be accessed—so long as the system is plugged in.

The RMC provides the following monitoring and control functions:

- Monitors thermal sensors, the power supply, and fans
- Detects alert conditions such as excessive temperature, fan failure, and power supply failure and sends an alert
- Performs remote power on/off, halt, and reset
- Dials a pager phone number or another computer system to notify the remote operator of an alert condition
- Shuts down the system if any fatal conditions exist

Upon an environmental event, the reason for failure is stored in the RMC NVRAM; the data can be retrieved to aid in diagnosing the problem.

## Control Panel

The system control buttons and indicator LEDs are located in the lower right corner on the front of the system.

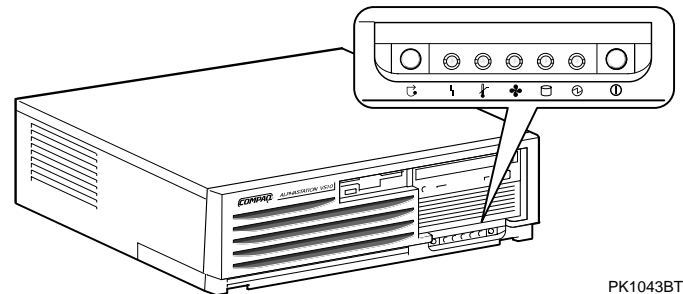

PK1043BT

The operation of the button at the left depends upon the setting of a jumper. It functions as a Halt button with *Tru64 UNIX* and *OpenVMS*.

## Server Management

The *AlphaServer* products support important operational and platform management requirements.

### Operational Management

*Server/Network Management.* *Comaq Insight Manager* is included with every system. This software tool allows you to monitor and control Alpha based servers. *Insight Manager* consists of two components: a Windows-based console application and server- or client-based management data collection agents. Management agents monitor over 1,000 management parameters. Key subsystems are instrumented to make health, configuration, and performance data available to the agent software. The agents act upon that data, by initiating alarms in the event of faults and by providing updated management information, such as network interface or storage subsystem performance statistics.

*Remote Server Management.* The integrated remote management console (RMC) lets the operator perform several tasks from a serial console: monitor the system power, temperature, and fans, and reset, halt, and power the system on or off. The monitoring can be done locally or remotely through a modem.

### Platform Management

The *AlphaServer* DS10 systems support platform management tasks such as manipulating and monitoring hardware performance, configuration, and errors. For example, the operating systems provide a number of tools to characterize system performance and display errors logged in the system error log file.

In addition, system console firmware provides hardware configuration tools and diagnostics to facilitate quick hardware installation and troubleshooting. The system operator can use simple console commands to show the system configuration, devices, boot and operational flags, and recorded errors. Also, the console provides inventory support and configuration management by giving access to serial numbers and revisions of hardware and firmware.

### Error Reporting

Compaq Analyze, a diagnostic service tool used to determine the cause of hardware failures, is installed with the operating systems. It provides automatic background analysis, as it constantly views and reads the error log file. It analyzes both single error/fault events and multiple events. When an error condition is detected, it collects the error information and sends it and an analysis to the user. The tool requires a graphics monitor for its output display.

### Security

- The top cover can be locked with a key.
- Password protection is offered by the SRM console and RMC.

## Reliability and Availability Features

The *AlphaServer* DS10 system achieves an unparalleled level of reliability and availability through the careful application of technologies that balance redundancy, error correction, and fault management. Reliability and availability features are built into the CPU, memory, and I/O, and implemented at the system level.

### Processor Features

- CPU data cache provides error correction code (ECC) protection.
- Parity protection on CPU cache tag store.
- Multi-tiered power-up diagnostics to verify the functionality of the hardware.

### Memory Features

- The memory ECC scheme is designed to provide maximum protection for user data. The memory scheme corrects single-bit errors and detects double-bit errors and total DRAM failure.

### I/O Features

- ECC protection on the switch interconnect and parity protection on the PCI and SCSI buses.
- Extensive error correction built into disk drives.
- Optional internal RAID improves reliability and data security.

### System Features

*Auto reboot.* On systems running *Tru64 UNIX* or *OpenVMS*, a firmware environment variable lets you set the default action the system takes on power-up, reset, or after an operating system crash. For maximum system availability, the variable can be set to cause the system to automatically reboot the operating system after most system failures.

*Software installation.* The operating systems are factory installed. Factory installed software (FIS) allows you to boot and use your system in a shorter time than if you install the software from a distribution kit.

*Diagnostics.* During the power-up process, diagnostics are run to achieve several goals:

- Provide a robust hardware platform for the operating system by ensuring that any faulty hardware does not participate in the operating system session. This maximizes system uptime by reducing the risk of system failure.
- Enable efficient, timely repair.

Audible beep codes report the status of diagnostic testing. The system has a firmware update utility (LFU) that provides update capability for console and PCI I/O adapter firmware. A fail-safe loader provides a means of reloading the console in the event of corrupted firmware.

*Thermal management.* The air temperature and fan operation are monitored to protect against overheating and possible hardware destruction. Four fans provide cooling. The system fan is under the floppy drive; another fan cools the PCI area. Also, a fan is mounted over the Alpha chip, and the power

supply has a fan. If the temperature rises, the system fan speeds up; or if necessary to prevent damage, the system shuts down.

*Error handling.* Parity and other error conditions are detected on the PCI bus. The memory checking scheme corrects single-bit errors and detects double-bit errors. Multiple ECC corrections to single-bit errors detected by the operating systems help in determining where in the system the error originated. Errors are logged for analysis.

*Uninterruptible power supply.* An external UPS can be purchased to support critical customer configurations. Because power is maintained for the entire system (CPU, memory, and I/O), power interruptions are completely transparent to users.

## Clustering

A cluster is a loosely coupled set of systems that behaves (is addressed and managed) like a single system, but provides high levels of availability through redundant CPUs, storage, and data paths. Clusters are also highly scalable; that is, CPU, I/O, storage, and application resources can be added incrementally to efficiently increase capacity. For customers, this translates to reliable access to system resources and data, and investment protection of both hardware and software.

Clustering allows multiple computer systems to communicate over a common interface, share disks, and spread the computing load across multiple CPUs.

### PCI to Memory Channel Interconnect

Under *Tru64 UNIX* and *OpenVMS*, you can build high-availability clusters using the PCI to Memory Channel interconnect. The Memory Channel interconnect is a high-bandwidth, low-latency PCI-based communications interconnect for up to eight *AlphaServer* systems. Data written to one computer's memory is shared by other computers on the Memory Channel bus.

The PCI adapter is the interface between a PCI and a Memory Channel bus. This bus is a memory-to-memory computer system interconnect that permits I/O space writes in one computing node to be replicated into the memories of all other nodes on the Memory Channel bus. A write performed by any CPU to its reflected address region results in automatic hardware updates to memory regions in other nodes. One node's write is "reflected" to other nodes as a direct side effect of the local write. This provides a memory region with properties similar to a high-performance shared memory across a group of nodes.

### Operating System Support

For clustered *Tru64 UNIX* systems, TruCluster Software solutions allow users access to network services and provide further failover recovery from server, network, or I/O failures. *Tru64 UNIX* cluster systems use the SCSI bus and/or PCI to Memory Channel interconnect bus between disks and systems.

*OpenVMS* cluster systems use the CI, SCSI, Ethernet, FDDI, and Memory Channel as the interconnect between disks and the system.

The primary means of clustering *AlphaServer* DS10 systems depends on the operating system.

- Ethernet, *OpenVMS*
- CI clusters, *OpenVMS* only
- Memory Channel, *Tru64 UNIX* and *OpenVMS*
- SCSI clusters, *Tru64 UNIX* and *OpenVMS*

## Performance

Compaq has an ongoing program of performance engineering, using industry-standard benchmarks that allow comparisons across major vendors' systems. These benchmarks against competitive systems are based on comparable CPU performance, coupled with comparable memory and disk expandability.

See Table 1 for the performance numbers of the *AlphaServer* DS10 systems. System performance, however, is highly dependent upon application characteristics. Thus, benchmark information is one helpful "data point" to be used in conjunction with other purchase criteria such as features, service, and price.

### Sources of Performance Information

Performance information is available on the Internet.

<http://www.compaq.com/alphaserver/performance/index.html>  
[http://www.ideasinternational.com/benchmark/spec/specfp\\_s2000.html](http://www.ideasinternational.com/benchmark/spec/specfp_s2000.html)

### Information for Compaq Partners

If you are a Channel or Reseller Partner, you can find the tools, resources, and information you need to conduct Compaq business online on the secure Compaq Partner Network extranet site:

<http://CPN.compaq.com>

Also see the Compaq Solutions Alliance site at

<http://csa.compaq.com>

## Service and Support

Compaq provides a comprehensive set of services that range from migration, consulting, and training, to direct support of Alpha systems, software, and applications. For information on Compaq Services, point your Web browser to <http://www.compaq.com/services>.

### Hardware Warranty

The *AlphaServer* DS10 system and components, including CPU, memory, PCI controllers, and power supplies, have a 3-year on-site, 5-day per week, 9-hour per day hardware warranty with next business day response time.

StorageWorks components are supported by the comprehensive StorageWorks warranty: five years for disks, three years for controllers, two years for tape devices, and one year for other components. The first year includes on-site next-day response time. Network products carry the network products warranty.

Users can upgrade to higher levels of service through a variety of hardware supplemental services.

### Software Warranty

The warranty for *Tru64 UNIX* and *OpenVMS* is conformance to SPD with advisory telephone support for a period of 90 days. Users can upgrade to higher levels of service through a variety of software supplemental services.

# Compaq AlphaServer DS10 System Diagrams

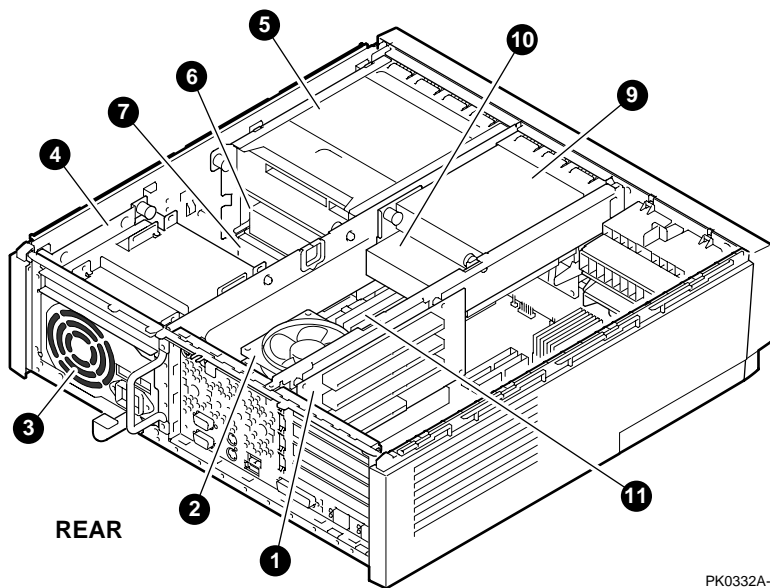
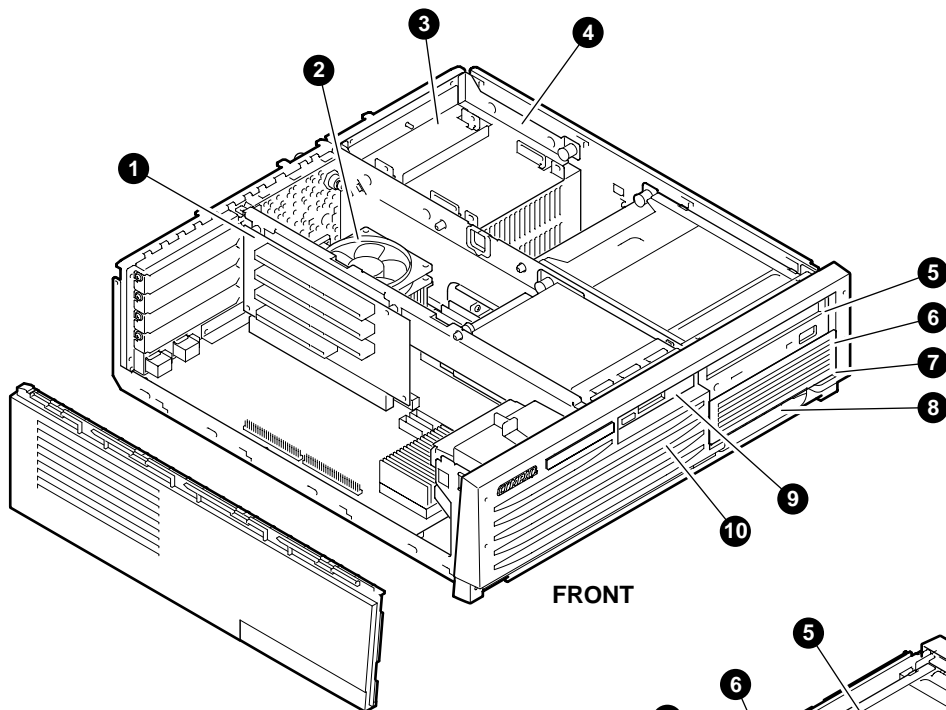

- 1. PCI riser card
- 2. CPU and fan
- 3. Power supply
- 4. Space for optional disk
- 5. CD-ROM
- 6. Optional bay
- 7. System disk
- 8. Control panel
- 9. Floppy diskette drive
- 10. Concealed optional bay
- 11. Memory

PK0332A-99

## I/O PORTS

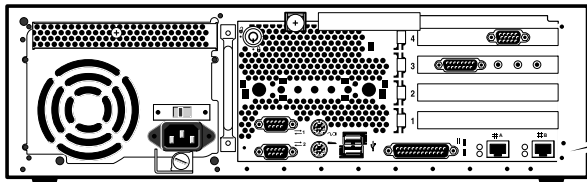

PK0334-99

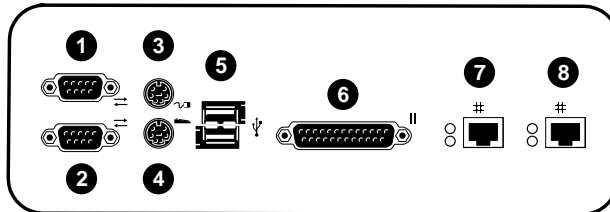

- 1. COM1 and RMC port
- 2. COM2 port
- 3. Mouse
- 4. Keyboard
- 5. USB ports (not supported)
- 6. Parallel port
- 7. Ethernet A
- 8. Ethernet B

## System Features at a Glance

Table 1 provides a quick reference to features of the *Compaq AlphaServer DS10* systems.

**Table 1 AlphaServer DS10 Features**

<b>CPU Features</b>	<b>6/466</b>	<b>67/600</b>
Processor	One Alpha 21264	One Alpha 21264A
CPU clock speed	466 MHz	600 MHz (actually 616 MHz)
Cache on chip	64 KB I-cache 64 KB D-cache	64 KB I-cache 64 KB D-cache
On-board cache	2 MB	2 MB
<b>Memory (maximum)</b>	2 GB	2 GB
<b>Performance</b>	<b>6/466</b>	<b>67/600</b>
SPECint2000	–	364
SPECfp2000	–	411
SPECint95	24.6	35.3
SPECfp95	47.9	56.1
SPECint_rate95	222	319
SPECfp_rate95	431	505
Linpack 100x100	–	483.4
Linpack (1kx1k)	–	900.9
SPECweb96	3,404 ops @ 17.6 msec	–
<b>Standard Features</b>	1.44 MB diskette drive, CD-ROM drive, 10/100 Mbit Ethernet ports, IDE controller, 2 serial ports, 1 parallel port, keyboard and mouse, integrated remote management console, rackmount slide kit, operating system license and customer documentation, Internet software	
<b>Internal Storage</b>		
Removable media	CD-ROM, floppy diskette, optional tape drive	
System storage	145 GB (4 disks or 3 disks and tape drive)	
<b>I/O System</b>		
I/O slots	3 64-bit PCI slots and 1 32-bit PCI slot	
Maximum PCI throughput	250 MB/sec	
<b>High Availability Features</b>		
System	Auto reboot, thermal management, remote management console, RAID, ECC memory, ECC cache, error logging, optional uninterruptible power supply. Also with rackmount: multiple systems, multiple power sources, dual-ported storage	
OpenVMS clusters	Ethernet, DSSI, SCSI, FDDI, PCI to Memory Channel Interconnect	
UNIX TruCluster Solutions	SCSI, PCI to Memory Channel Interconnect	
<b>Operating Systems</b>	<i>Tru64 UNIX</i> , <i>OpenVMS</i> , and Linux	
<b>Warranty</b>		
Hardware	3-year, on-site, 5 day x 9 hour warranty with next business day response	
Software	90-day telephone advisory support for <i>OpenVMS</i> and <i>Tru64 UNIX</i>	

## Physical Characteristics

Table 2 details basic physical characteristics of the system.

**Table 2 AlphaServer DS10 Physical Characteristics**

<b>Dimensions</b>			
Height	13.0 cm (5.1 in.)		
Width	44.6 cm (17.6 in.)		
Depth	48.4 cm (19.1 in.)		
Weight	14.5 kg (32 lb) typical; 16.3 kg (36 lb) maximum		
<b>Environmental</b>			
Temperature	Operating	10–40° C (50–104° F)	
	Nonoperating	–40 to 66° C (–40 to 151° F)	
Humidity (noncondensing)	Operating	20–80%	
	Nonoperating	10–95%	
Maximum altitude (unpressurized)	Operating	3037 m (10,000 ft)	
	Nonoperating	12,192 m (40,000 ft)	
Nonoperating shock	30 G, 25 ms halfsine		
<b>Electrical</b>			
Nominal voltage range (Vac)	100–120/220–240		
Operating voltage range (Vac)	90–128/180–265		
Power source phase	Single/Single		
Nominal frequency (Hz)	60/50		
Frequency range (Hz)	59–61/49–51		
Maximum inrush current (amps)	11/22		
Single power supply (amps)	12/5		
<b>Acoustics—Declared values per ISO 9296 and ISO 7779</b>			
Current values for specific configurations are available from Compaq. 1 B = 10 dBA			
DS10 with 1 HDD	$L_{Wad}$ , B	$L_{pAm}$ , dBA (operator position)	$L_{pAm}$ , dBA (bystander positions)
Idle	5.7	48	41
Operating	6.0	52	45



© 2001 Compaq Computer Corporation

Compaq, the Compaq logo, Compaq Insight Manager, AlphaServer, StorageWorks, and TruCluster Registered in U.S. Patent and Trademark Office. OpenVMS and Tru64 are trademarks of Compaq Information Technologies Group, L.P. in the United States and other countries.

Linux is a registered trademark of Linus Torvalds in several countries. SPECint95, SPECfp95, SPECint2000, SPECfp2000, and SPECweb96 are registered trademarks of the Standard Performance Evaluation Corporation. UNIX is a trademark of The Open Group in the United States and other countries. All other product names mentioned herein may be trademarks of their respective companies.

Compaq shall not be liable for technical or editorial errors or omissions contained herein. The information in this document is provided "as is" without warranty of any kind and is subject to change without notice. The warranties for Compaq products are set forth in the express limited warranty statements accompanying such products. Nothing herein should be construed as constituting an additional warranty.