



Pocket Service Guide

Digital Equipment Corporation

First Edition, December 1982
Second Edition, March 1984

©Digital Equipment Corporation 1984.
All Rights Reserved.

The information in this document is subject to change without notice and should not be construed as a commitment by Digital Equipment Corporation. Digital Equipment Corporation assumes no responsibility for any errors that may appear in this document.

WARNING: The Rainbow computer has been certified to comply with the limits for a Class B computing device, pursuant to Subpart J of Part 15 of FCC rules. Only peripherals (computer input/output devices, terminals, printers, etc.) certified to comply with the Class B limits may be attached to this computer. Operation with noncertified peripherals is likely to result in interference to radio and television reception.

CP/M[®], CP/M[®]-80, CP/M-86[®], and CP/M[®]-86/80 are registered trademarks of Digital Research Inc.

MS[™]-DOS is a trademark of Microsoft Corporation.

Z80[®] is a registered trademark of Zilog, Inc.

The manuscript for this book was created using a DIGITAL Word Processing System and, via a translation program, was automatically typeset on DIGITAL's DECset Integrated Publishing System. Book production was done by Educational Services Development and Publishing in Marlboro and Bedford, MA.

The following are trademarks of Digital Equipment Corporation:

digital [™]	DIBOL	RSX
DEC	MASSBUS	UNIBUS
DECmate	PDP	VAX
DECsystem-10	P/OS	VMS
DECSYSTEM-20	Professional	VT
DECUS	Rainbow	Work Processor
DECwriter	RSTS	

Printed in U.S.A.

CONTENTS

PREFACE

1 OVERVIEW

1.1	Introduction	1
1.2	System Block Diagram	4

2 SET-UP FEATURES

2.1	Introduction	5
2.2	Set-Up Menus	7
2.2.1	Tabs Set-Up Menu	7
2.2.2	Parameter Settings Set-Up Menu	8
2.2.3	Modem Set-Up Menu	12
2.2.4	Printer Set-Up Menu	13
2.2.5	Miscellaneous Set-Up Menu	14
2.2.6	Auto-Boot Set-Up Menu	14
2.2.7	Memory Set-Up Menu	17

3 TESTING AND TROUBLESHOOTING

3.1	Introduction	19
3.2	Testing Strategy	19
3.3	Diagnostic Diskette Tests	33
3.3.1	Test Drives A and B	50
3.3.2	Test Computer	50
3.3.3	Display Individual Test Menu	50
3.3.4	Install New Diagnostic Test	53
3.4	Exiting a Diagnostic	53
3.5	Diskette Care	53

4 MONITOR ADJUSTMENTS

4.1	Introduction	55
4.2	Preparation	55
4.3	Adjustments	60

4.3.1	Brightness and Contrast	60
4.3.2	Vertical Hold (VH)	61
4.3.3	Horizontal Hold (HH)	62
4.3.4	Focus	62
4.3.5	Vertical Centering and Rotation Check without Color/Graphics Option	63
4.3.6	Vertical Centering and Rotation Check for Color/Graphics Option	64
4.3.7	Horizontal Centering and Width Coil	65
4.3.8	Cutoff	67
4.3.9	Height and Vertical Linearity	67
4.3.10	Horizontal Centering for Color/ Graphics Option	68
4.3.11	Aspect Ratio (Horizontal Width and Height) for Color/Graphics Option ...	69
4.3.12	Vertical Linearity for Color/ Graphics Option	70

5 REMOVAL AND REPLACEMENT PROCEDURES

5.1	Introduction	73
5.2	Remove System Unit from Floor Stand	75
5.3	Top Cover Removal	76
5.4	System Module Removal and Installation	77
5.5	RX50 Controller Module Removal	82
5.6	Memory Board Removal	83
5.7	Color/Graphics Option Board Removal	84
5.8	Extended Communications Option Board Removal	84
5.9	Hard Disk Controller Board Removal	85
5.10	ROM Removal	86
5.10.1	PC100A ROMs 0 and 1 Removal and Replacement	86
5.10.2	PC100A ROM 2 (Language ROM) Removal and Replacement	89
5.10.3	PC100B ROMs 0 and 1 Removal and Replacement	89
5.11	RX50 Diskette Drive Removal	91

5.12	RD51 Hard Disk Drive (Winchester) Removal	93
5.13	Hard Disk Drive Cable Removal and Installation	95
5.14	Hard Disk Drive Installation	98
5.15	Keyboard Replacement	100
5.16	Fan Bracket Assembly Removal	100
5.17	Power Switch (1/0) Removal	102
5.18	Fan Removal (PC100A)	103
5.19	Fan Removal (PC100B)	104
5.20	Power Supply Removal	105
5.21	Monitor Removal	113
5.22	Monitor Module Removal	114
5.23	Monitor Module Replacement	122

A RAINBOW COMPUTER PARTS LIST

B MEMORY OPTION TEST PROCEDURE

B.1	Introduction	129
B.1.1	Turning on the Computer (PC100B only)	129
B.1.2	PC100B Memory Board Options	130
B.2	Test Procedure	130
B.2.1	A Successful Test	132
B.2.2	An Unsuccessful Test	133
B.3	Configurations	139
B.4	Failure Code Key	146

C EXTENDED COMMUNICATIONS OPTION TEST PROCEDURE

C.1	Introduction	149
C.2	Testing	149
C.2.1	Access Test	150
C.2.2	Starting Internal Tests	151
C.2.3	Proceeding from an Error	152
C.2.4	Starting External Testing	153
C.2.5	External Test Failed	154
C.3	Faults, Error Messages, and Corrective Action	155
C.4	Extended COMM Connector Pin Locations	166

D COLOR/GRAPHICS OPTION TEST PROCEDURE

D.1	Introduction	167
D.2	Testing	167
D.2.1	Main GSX-86 Menu Access	168
D.2.2	Monitor Hardware Selection	169
D.2.3	Select Tests	170
D.2.4	Starting Graphics Tests	171
D.2.5	Completed Graphics Tests	172
D.2.6	Failed Graphics Test	173
D.2.7	Proceeding from an Error	173
D.3	Faults, Error Messages, and Corrective Action	174

E WINCHESTER (HARD) DISK OPTION TEST PROCEDURE

E.1	Introduction	179
E.2	Testing and Initializing the Hard Disk Drive	180
E.2	Run the Hard Disk Diagnostic	183
E.4	Faults, Error Messages, and Corrective Action	184

INDEX

FIGURES

1-1	The Rainbow Computer	1
1-2	The Rainbow Computer with System Unit in Floor Stand	2
1-3	Rainbow Computer Block Diagram	4
2-1	Rainbow Main System Menu	6
2-2	Tabs Set-Up Menu	7
2-3	Parameter Settings Set-Up Menu	8
2-4	Language Selection Menu	11
2-5	Modem Set-Up Menu	12
2-6	Printer Set-Up Menu	13
2-7	Miscellaneous Set-Up Menu	14
2-8	Auto-Boot Set-Up Menu (PC100B only)	15
2-9	Memory Set-Up Menu (PC100A only)	17
3-1	Diagnostic Error Message Lights	19
3-2	Rainbow Main System Menu	20

3-3	Inserting Diskette in Drive A or C	33
3-4	Inserting Diskette in Drive B or D	34
3-5	Main Diagnostic Menu	34
3-6	Individual Test Menu	50
3-7	Diskette Care	54
4-1	Monitor Cover Removal	56
4-2	Sources of High Voltage	57
4-3	Discharging the CRT Anode	58
4-4	Connecting the Monitor for Adjustments	59
4-5	Brightness and Contrast Controls	60
4-6	Vertical and Horizontal Hold Controls	61
4-7	Focus Control	62
4-8	Vertical Centering and Rotation Check with Alignment Template	64
4-9	Monitor Module Controls – Left Side	65
4-10	Width Coil	66
4-11	Horizontal Centering	68
4-12	Aspect Ratio	69
4-13	Sources of High Voltage	71
5-1	FRU Removal Sequence	74
5-2	Removing System Unit from Floor Stand	75
5-3	System Unit Top Cover Removal	76
5-4	Power Cable Removal	77
5-5	Hard Disk Drive Cable Removal	78
5-6	Diskette Drive Flat Cable Removal	79
5-7	System Module Removal	80
5-8	Installing Hard Disk Cable	81
5-9	RX50 Controller Board Removal	82
5-10	Memory Board Removal	83
5-11	Color/Graphics Option Board Removal	84
5-12	Extended Communications Option Board Removal	85
5-13	Hard Disk Controller Board Removal	86
5-14	ROM Removal on PC100A	87
5-15	ROM Removal on PC100B	90
5-16	Inserting Protective Card	91
5-17	Diskette Drive Flat Cable and 4-Wire Power Cable Removal	92

5-18	Ground Clip and Hard Disk Drive Removal	93
5-19	Hard Disk Drive 4-Wire Power Cable and Hard Disk Drive Cable Removal	94
5-20	Power Cable Removal	95
5-21	Hard Disk Drive Cable Removal from Controller	96
5-22	Connecting Hard Disk Drive Cable Firmly	97
5-23	Hard Disk Drive Cable and 4-Wire Power Cable Installation (to disk drive)	98
5-24	Fastening Ground Clip to Power Supply	99
5-25	Unplugging Fan Assembly Plugs and DC Fan Cable	100
5-26	Fan Bracket Assembly Removal	101
5-27	Removing Power Switch	102
5-28	Fan in PC100A	103
5-29	Fan in PC100B	104
5-30	Unplugging 4-Wire Cable and Ground Clip	105
5-31	Unplugging Ground Clip and Sliding Hard Disk Drive Forward	106
5-32	Unplugging 4-Wire Cable	107
5-33	Unplugging DC Fan Cable and Plugs Near Fan	108
5-34	Unplugging Power Cable from Power Supply	109
5-35	Unplugging Hard Disk Drive Cable from Controller	110
5-36	Unplugging Diskette Drive Flat Cable(s)	111
5-37	Removing the Power Supply	112
5-38	Check Voltage Setting	113
5-39	Monitor Cover Removal	114
5-40	Sources of High Voltage	115
5-41	Discharging CRT Anode	117
5-42	Anode Removal	118
5-43	Removing CRT Connector	119
5-44	Monitor Module Rear Panel Removal	120
5-45	Monitor Module Standoff Removal	121

5-46	Monitor Module Cutoff Control	122
B-1	Main System Menu with Message	129
B-2	Main Diagnostic Menu	130
B-3	Individual Test Menu	131
B-4	Individual Diagnostic Test	131
B-5	Main Diagnostic Menu with Test-Passed Message	132
B-6	Individual Diagnostic Test with a Failure Message	133
B-7	Individual Diagnostic Test with a Faulty Memory Component Message	134
B-8	Memory Board Chip Location Map	135
B-9	Memory Board Option Removal	135
B-10	Chip-to-Board Orientation	136
B-11	Chip Removal	136
B-12	Chip Size Identification	137
B-13	Switch Location with Typical Settings	138
B-14	Chip Bank Identification	139
B-15	Memory Chip Size	139
B-16	Configuration 1	140
B-17	Configuration 2	141
B-18	Configuration 3	142
B-19	Configuration 4	143
B-20	Configuration 5	144
B-21	Configuration 6	144
B-22	Configuration 7	145
B-23	Configuration 8	145
B-24	Memory Board Chip Location	146
C-1	Individual Diagnostic Test	150
C-2	Internal Tests Running	151
C-3	Internal Test Failure Message	152
C-4	Internal Tests Complete	153
C-5	Inserting Loopback Plug	153
C-6	All Tests Complete	154
C-7	Untitled	155
C-8	Untitled	157
C-9	Untitled	157
C-10	Untitled	159
C-11	Untitled	159
C-12	Untitled	161
C-13	Untitled	161
C-14	Untitled	163

C-15	Untitled	163
C-16	Untitled	165
C-17	Untitled	165
C-18	COMM Connector Pin Assignments	166
D-1	Main GSX-86 Menu	168
D-2	Monitor Hardware Selection	169
D-3	Test Selection Menu	170
D-4	Tests in Progress	171
D-5	All Tests Complete	172
D-6	Screen with Failure Message	173
D-7	Untitled	175
D-8	Untitled	175
D-9	Untitled	177
D-10	Untitled	177
E-1	Rainbow Hard Disk Utility Program Main Screen	181
E-2	Testing and Formatting Drive, Wait	181
E-3	FATAL ERROR Screen	182
E-4	Testing and Initialization Process Complete	182
E-5	Hard Disk Option Diagnostic Complete	183
E-6	Subtest 1 Failure: R/W Error in Head Select Register	184
E-7	Subtest 2 Failure: Drive: Drive Not Ready	185
E-8	Subtest 4 Failure: Hard Disk Controller: Improper Status, Command Completion	186
E-9	Subtest 7 Failure: Controller or Drive ?, Data Error, Bad Write or Read	187

TABLES

1-1	Rainbow Computer Comparison	3
3-1	Internal Diagnostic Test Messages	21
3-2	Diagnostic Test Messages	35
A-1	Rainbow Computer Parts List	125
B-1	Failure Code Table	147

PREFACE

This pocket service guide provides Field Service personnel with quick reference information about the Rainbow™ computer. It provides little information about theory and system concepts; instead, it includes the practical information needed in the field. The guide is divided into the following chapters and appendixes.

- **Chapter 1, Overview**, provides general information about the physical characteristics of the computer.
- **Chapter 2, Set-Up Features**, lists all of the Set-Up features, explains their functions, and tells how to change them.
- **Chapter 3, Testing and Troubleshooting**, explains how to run the diagnostic tests and interpret error messages.
- **Chapter 4, Monitor Adjustments**, provides step-by-step instructions for performing adjustments to the VR201-A black and white monitor.
- **Chapter 5, Removal and Replacement Procedures**, provides step-by-step instructions for replacing field replaceable units (FRUs).
- **Appendix A, Rainbow Computer Parts List**, lists the recommended spare parts for the Rainbow computer.
- **Appendix B, Memory Board Test Procedure**, provides instructions for testing your memory board when you install it or increase its size.
- **Appendix C, Extended Communications Option Test Procedure**, provides instructions for testing your extended communications option.
- **Appendix D, Color/Graphics Option Test Procedure**, provides instructions for testing your color/graphics option.
- **Appendix E, Winchester (Hard) Disk Option Test Procedure**, provides instructions for testing your Winchester (hard) disk option.

Customers should call the Digital Customer Help Line number, 800-DEC-8000, for assistance. For additional information about the Rainbow computer, refer to the following documents.

Title	Digital Part Number
Rainbow™ Installation Guide	EK-R100E-IN
Rainbow™ 100 Owner's Manual	EK-P100E-OM*
Rainbow™ Owner's Manual	EK-R100E-OM†
Rainbow™ 100 User's Service Guide	EK-P100E-SV
Rainbow™ Memory Board Option Installation Guide	EK-RBMXE-IN
PC100 Rainbow™ 100 System Unit IPB	EK-SB100-IP
Rainbow™ 100 Technical Manual	EK-PC100-TM
Rainbow™ Winchester Disk Option Installation Guide	EK-RBWIN-IN†
Rainbow™ 100 Winchester Disk Option Upgrade and Installation Guide	EK-PCWIN-IN*
Rainbow™ Color/Graphics Option Installation Guide	EK-PCCOL-IN
Rainbow™ 100 Extended Communications Option Installation Guide	EK-PCEXC-IN
Rainbow™ 100 Extended Communications Programmer's Reference Guide	AA-V172A-TV
Rainbow™ CP/M®-86/80 Getting Started	AA-Y523B-TV
Rainbow™ CP/M®-86/80 User's Guide	AA-Y524A-TV
Rainbow™ MS™-DOS User's Guide	AA-Y894A-TV
Rainbow™ MS™-DOS Advanced User's Guide	AA-Y983A-TV
Rainbow™ 100 Getting Started	AA-N575B-TV*
Rainbow™ 100 User's Guide	AA-P300B-TV*
Rainbow™ GSX-86 Getting Started	AA-V526A-TV
Rainbow™ GSX-86 Programmer's Reference Manual	AA-W964A-TV
VR241-A Color Video Monitor Pocket Service Guide	EK-VR241-PS

*Rainbow 100A only

†Rainbow 100B only

NOTE

There are two different versions of the owner's manual. These manuals are not labeled 100A or 100B, and a customer having both versions of the computer may refer to the wrong manual. Check the manual and advise the customer. The manual for the 100A version has three magenta strips on the cover; the manual for the 100B version has a rainbow on the cover.

The keys on the Rainbow keyboard that are mentioned in the following text appear in **boldface**, often within angle brackets (for example, "press <**Shift**>"). Note that <**Return**> represents the **Return** key, and to press <**Shift/A**> means to hold down the **Shift** key and press the **A** key at the same time.

NOTE

There are two different editions of this book. The first edition was published in 1938 and the second edition in 1939. The first edition was published in 1938 and the second edition in 1939. The first edition was published in 1938 and the second edition in 1939.

The book is a study in the history of the city of Vienna. It is a study in the history of the city of Vienna. It is a study in the history of the city of Vienna. It is a study in the history of the city of Vienna.

1 OVERVIEW

1.1 INTRODUCTION

The Rainbow computer is a personal computer that uses a Z80®A processor and an 8088 processor. The Z80A 8-bit processor allows the Rainbow computer to use the hundreds of application programs that run with the CP/M®-80 operating system. The 8088 processor is a newer, faster 16-bit processor that runs application programs with the CP/M-86® operating system. The CP/M®-86/80 operating system that your Rainbow computer uses is a combination of these two operating systems. The Rainbow computer also uses the MS™-DOS operating system.

Physically, the typical Rainbow computer system is made up of a system unit, a monitor, and a keyboard as illustrated in Figure 1-1. A printer is optional.

You can set the system unit on a table as in Figure 1-1, or mount it vertically in the optional floor stand as in Figure 1-2. The system unit contains the processors and a dual-diskette drive that holds two 5-1/4 inch flexible diskettes. As an option, you can install a second dual-diskette drive or a hard disk drive (Winchester).

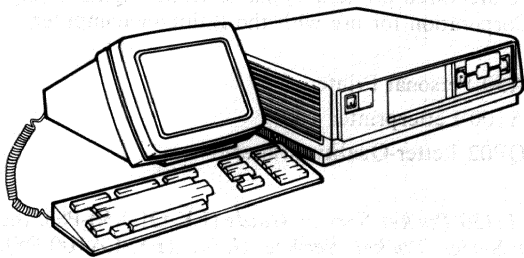

Figure 1-1 The Rainbow Computer

Z80®A is a registered trademark of Zilog, Inc.

CP/M®-80, CP/M-86® and CP/M®-86/80 are registered trademarks of Digital Research Inc.

MS™-DOS is a trademark of Microsoft Corporation.

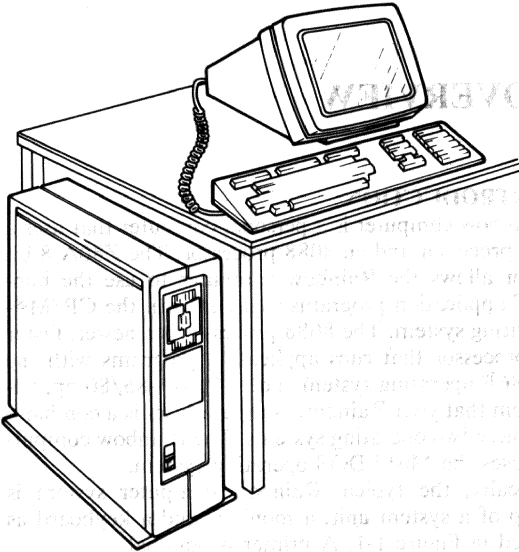

Figure 1-2 The Rainbow Computer with System Unit in Floor Stand

The monitor is the VR201-A black and white monitor; the keyboard is the low profile LK201-AA keyboard.

There are three printers available from Digital Equipment Corporation for use with the Rainbow computer.

- LA50 Personal Printer
- LA100 Letterprinter 100
- LQP02 Letter-Quality Printer

The *LA50 Pocket Service Guide (EK-OLA50-PS)*, the *LA100 Series Pocket Service Guide (EK-LA100-PS)*, and the *LQP02 Pocket Service Guide (EK-LQP02-PS)*, respectively, provide troubleshooting and repair information for these printers. You can use other serial printers, if they meet the Class B FCC rating.

There are three versions of the Rainbow computer in the field – the PC100A, the PC100A with a Winchester upgrade kit, and the PC100B. Table 1-1 compares these three versions of the Rainbow computer.

Table 1-1 Rainbow Computer Comparison

	Rainbow PC100A	Rainbow 100A with Winchester Upgrade Kit	Rainbow PC100B
Fan	AC	AC	DC
Power supply	H7842-A	H7842-D	H7842-D
DC fan cable	Not present	Yes, but not used	Yes
System module	PC100A (70-19974-00)	PC100A (70-19974-00)	PC100B (70-19974-02)
ROMs	3 (24K bytes)	3 (24K bytes)	2 (32K bytes)
Main system memory	64K bytes	64K bytes	128K bytes
Memory options	64K and 192K bytes (with no chip sockets)	64K and 192K bytes (with no chip sockets)	128K and 256K bytes with chip sockets for adding memory
Total memory capacity	256K bytes	256K bytes	896K bytes
Auto-matic memory sizing	No	No	Yes
Winchester (hard disk) capability	No	Yes	Yes
Auto-boot capability	No	No	Yes

1.2 SYSTEM BLOCK DIAGRAM

Figure 1-3 is a block diagram of the Rainbow computer (PC100B). Other than the differences listed in Table 1-1, the other two Rainbow computers function similarly. In all versions, the Z80A and 8088 processors perform different system functions. The Z80A processor has 2K bytes of dedicated memory. It also shares 62K bytes with the 8088 processor. The Z80A processor controls the transfer of data between the RX50 diskette drive and the 62K bytes of shared memory.

The 8088 processor shares 62K bytes of memory with the Z80A processor but has exclusive use of the optional memory board. The 8088 processor controls the keyboard, the monitor, the modem connection to communicate with a host system, and the printer.

The read-only memory (ROM) contains the programming for the power-up test, the selftest, the Main System Menu, the Set-Up features, the language selection, and certain I/O (input/output) functions.

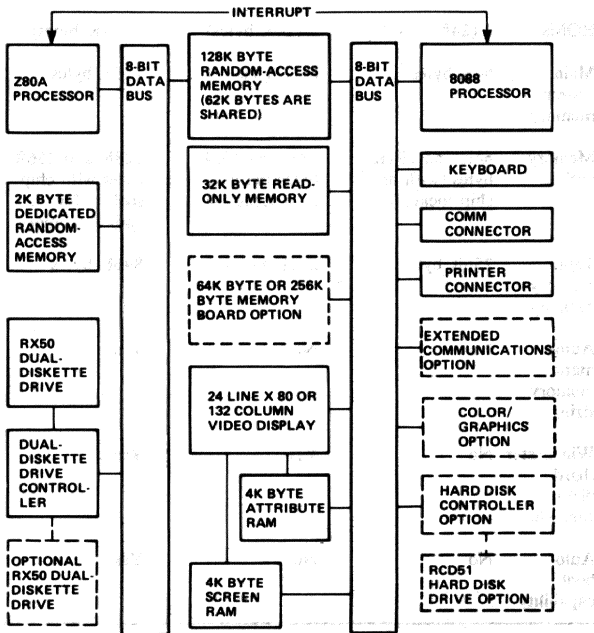

Figure 1-3 Rainbow Computer Block Diagram

2 SET-UP FEATURES

2.1 INTRODUCTION

Set-Up features control how the Rainbow computer displays text on the screen, sends characters to a printer, and communicates with a host system. They allow users to tailor their computers for convenience and to match their external devices.

To change a Set-Up feature, you enter Set-Up, step through the various Set-Up menus until you reach the one you want, and make the change. If you want a change to be permanent, that is, to remain in effect after you turn the system off and back on again, you must save the Set-Up features. You use the following procedures to manipulate the Set-Up features.

The keys on the Rainbow keyboard that are mentioned in the following text appear in **boldface**, often within angle brackets (for example, "press <Shift>"). Note that <Return> represents the Return key, and to press <Shift/A> means to hold down the Shift key and press the A key at the same time.

- To enter Set-Up, you press <Set-Up>.
- To leave Set-Up, you press <Set-Up> again.
- To move to another Set-Up menu, you press the <Next Screen> or <Prev Screen> key.
- To select another variable within a Set-Up menu, you press ◀ or ▶.
- To change the value of a variable, you press ▲ or ▼.
- To save the Set-Up features, you enter Set-Up and press <Shift/S>. This saves the current Set-Up features in nonvolatile memory (NVM) so they will not be lost when you turn the system off.
- To recall the Set-Up features, you enter Set-Up and press <Shift/R>. This returns the Set-Up features to what they were the last time they were saved. With Set-Up, this is the same as turning the system off and then back on again. When you recall the Set-Up features, the text that was on the screen before you entered Set-Up is lost.

6 SET-UP FEATURES

- To restore the default Set-Up features, you enter Set-Up and press <Shift/D>. This changes all the Set-Up features to the features the system had when it was originally shipped. This set of features is adequate for many installations. When you restore the default Set-Up features, the text that was on the screen before you entered Set-Up is lost.
- To perform a system reset, you enter Set-Up and press <Ctrl/Set-Up>. This stops whatever program, diagnostic, or operating system is running, performs a brief test (3 seconds), and returns you to the Main System Menu.

Local and Line Modes

The local/line mode selection only affects the Rainbow computer when it is in terminal mode. In line mode, the mode you will normally use, the computer interacts with the host system, sending all the characters you type on the keyboard to the host system and letting the host system process and echo the characters on the screen. In local mode, the Rainbow computer acts like a typewriter. The computer displays everything you type on the screen but does not send it to the host system or process it by itself. To change from line mode to local mode or from local mode back to line mode, enter Set-Up and press L.

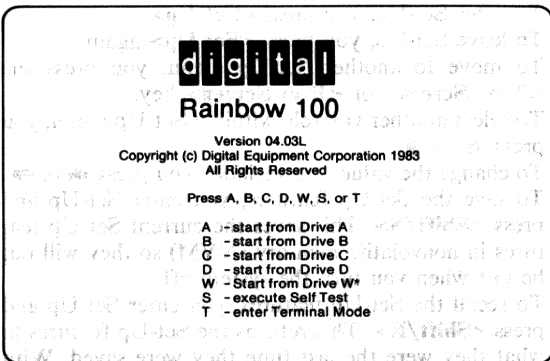

**W = Start from Drive W* is not on the PC100A Main System Menu.

Figure 2-1 Rainbow Main System Menu

When the Rainbow computer is in terminal mode and in line mode, it acts like a terminal: it sends all the characters you type on the keyboard to the host system instead of processing them itself. The host system processes the characters and echoes them on the screen. The computer must be in line mode to communicate with a host system. To enter terminal mode, you press **T** at the Main System Menu shown in Figure 2-1. To leave terminal mode and return to the Main System Menu, you reset the computer (enter Set-Up and press **<Ctrl/Set-Up>**).

2.2 SET-UP MENUS

There are six Set-Up menus in each version of the Rainbow computer, and each menu has selections that you can change. A discussion of these Set-Up menus and their selections follows.

2.2.1 Tabs Set-Up Menu

The Tabs Set-Up menu is shown in Figure 2-2. You use the **◀** and **▶** keys to select tab columns; you use the **◆**, **◀**, or **T** keys to set and clear tab stops. You press **<Ctrl/Tab>** to clear all of the tabs; you press **<Shift/Tab>** to restore the default tab settings.

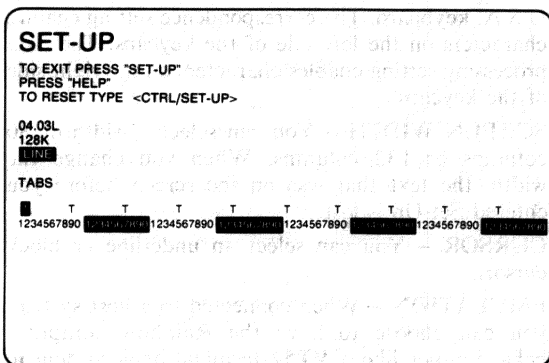

Figure 2-2 Tabs Set-Up Menu

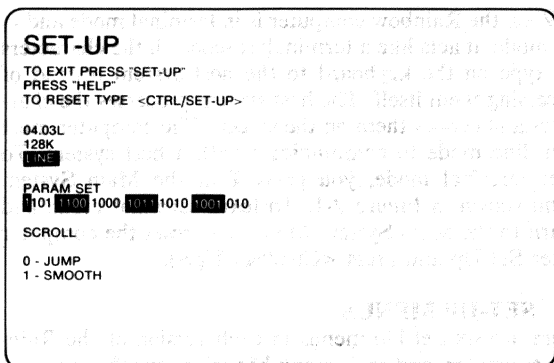

Figure 2-3 Parameter Settings Set-Up Menu

2.2.2 Parameter Settings Set-Up Menu

Figure 2-3 shows the Parameter Settings (Param Set) Set-Up menu. You can use this menu to manipulate the following features.

1. **SCROLL** – You can select smooth or jump scrolling.
2. **CORRESPONDENCE/DATA PROC KYBD** – You use this feature with keyboards other than the U.S.A. keyboard. The correspondence setting enables characters on the left side of the keycaps. The data processing setting enables characters on the right side of the keycaps.
3. **SCREEN WIDTH** – You can select a width of 80 columns or 132 columns. When you change the width, the text that was on the screen before you entered Set-Up is lost.
4. **CURSOR** – You can select an underline or block cursor.
5. **EMULATION** – When connected to a host system, you can choose to have the Rainbow computer behave either like a VT52 terminal or according to the American National Standards Institute (ANSI) standard.
6. **AUTO REPEAT** – You can choose to have keyboard keys repeat when you hold them down.
7. **SCREEN** – You can select a dark (white characters on a black screen) or light screen display.

8. **MARGIN BELL** - You can choose to have a bell sound when you near the end of a line of typing.
9. **KEYCLICK** - You can choose to have keys click when you press them.
10. **AUTO-WRAP** - You select on to have the computer automatically start a new line when the text reaches the edge of the screen. You should set this to off for CP/M-86/80 application software.
11. **NEW LINE MODE** - You can select LF (line feed) or NL (new line) when using the Rainbow computer as a terminal; however, you must use LF (the 0 setting) when using the Rainbow as a personal computer to use the software that comes with the computer. Line feed is the default value.
12. **DEFAULT CHARACTER SET** - You can select US ASCII for the # character or UK for the £ character.
13. **AUTO-SCREEN BLANK** - You can choose to have the screen go blank after it has been idle for more than 30 minutes. A phantom cursor remains on the screen.
14. **POWER** - You can match the monitor scan rate to the power line frequency to prevent screen jitter.
15. **PRINT TERM CHAR** - You can select a print termination character. When set to FF (1), the system automatically sends a form feed character to the printer at the end of each print screen function. Used only for terminal mode.
16. **PRINT EXTENT** - You can select scroll region or full screen. When set to scroll region, the computer prints only the lines selected by the host system. Used only for terminal mode.
17. **AUTO-XON/XOFF** - You can choose to enable the XON and XOFF signals. When on, the Rainbow computer uses XON and XOFF control signals to tell the host system to pause when the Rainbow computer's incoming buffer is full so that characters are not lost. Used only for terminal mode.
18. **LOCAL ECHO** - You can choose to turn local echo on or off. It is normally off. You should turn it on when connected to a host system that does not echo the characters on the screen as you type them. Used only for terminal mode.
19. **XMT BREAK** - You can choose to enable or disable the **Break** key. Used only for terminal mode.

10 SET-UP FEATURES

20. **MODEM STOP BITS** – You can select modem stop bits. Normally, you use 1 stop bit at baud rates over 110, and 2 bits at 110 and slower. Used only for terminal mode.
21. **RCV CHAR PARITY** – You can check for or ignore incoming data parity errors. Used only for terminal mode.
22. **AUTO-ANSBK** – You can turn auto-answerback on or off. If auto-answerback is on, the Rainbow computer automatically sends a message to the host computer when a connection is made, when the host sends an ENQ code, or when you press **<Ctrl/Break>**. To store an answerback message, press **<Shift/A>**, follow this with any convenient delimiter character that you are not going to use in your message, (e.g., / or *), type your message (up to 20 characters), and follow your message with the same delimiter character. For example, to use Auto-Ansbk to log in on a host computer whenever you turn on your Rainbow computer, you might type the following.

<Shift/A>*LOGIN PASSWORD<Return>*

<Return> is displayed on the screen as a reverse video M. Used only for terminal mode.

23. **DISCONNECT CHAR USE** – You can choose to enable a disconnect character to disconnect a telephone line. Used only for terminal mode.
24. **DISCONNECT DELAY** – You can set how long the system will wait after loss of telephone carrier before disconnecting. In the United Kingdom, 60 ms is typical; in the United States and other countries, 2 seconds is typical. This value is only used with FDXB and FDXC modem protocols; it is ignored with FDXA. See Paragraph 2.2.3, Modem Set-Up Menu. Used only for terminal mode.
25. **LOCK MODE** – You can choose how you want to use the **Lock** key. Keyboards other than the U.S.A. keyboard generate a different set of characters depending on how Lock Mode is set. If you select caps lock, only the alphabetic keys will generate shifted characters. If you select shift lock, all keys will generate shifted characters.

26. **KEYBOARD (PC100B only)** – You can choose another keyboard language with this setting. Change the setting to 0, press **<Shift/S>** to save the setting, and reset the computer by pressing **<Ctrl/Set-Up>**. The computer will display the language selection menu (Figure 2-4). Follow instructions on the screen to select a new language.

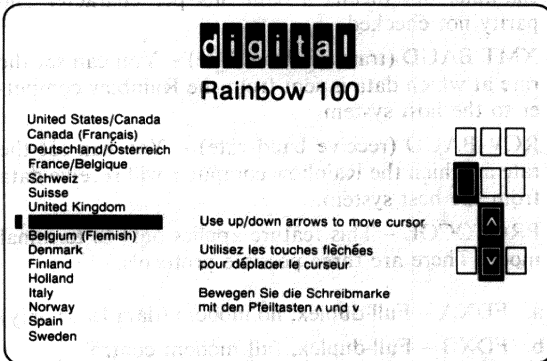

Figure 2-4 Language Selection Menu

27. **CHARACTER CODES (PC100B only)** – You can select the DEC Multinational Character set, which has 256 characters and uses 8 bits to code each character, or you can select the National Replacement Character set, which has 128 characters and uses 7 bits to code each character.

2.2.3 Modem Set-Up Menu

You use the Modem Set-Up menu, shown in Figure 2-5, to configure the Rainbow computer to communicate with a host system. There are four modem Set-Up features.

1. **DATA B/P** (data bits and parity) – You can set data bits to 7 or 8 data bits per character. You can set parity to odd, even, or no parity (not checked). For example, 8N means 8 data bits per character and parity not checked.
2. **XMT BAUD** (transmit baud rate) – You can set the rate at which data is sent from the Rainbow computer to the host system.
3. **RCV BAUD** (receive baud rate) – You can set the rate at which the Rainbow computer will receive data from the host system.
4. **PROTOCOL** – This feature applies only to terminal mode. There are three possible protocols.
 - a. **FDXA** – Full-duplex, no modem (data leads only)
 - b. **FDXB** – Full-duplex, full modem control
 - c. **FDXC** – Asymmetrical full-duplex with full modem control (requires a special cable)

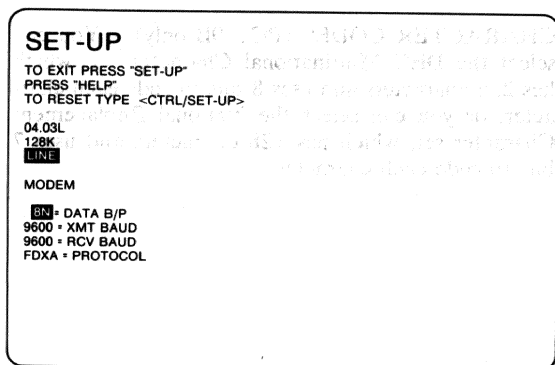

Figure 2-5 Modem Set-Up Menu

2.2.4 Printer Set-Up Menu

You use the Printer Set-Up menu, shown in Figure 2-6, to configure the Rainbow computer to communicate with its printer. There are two printer Set-Up features.

1. **DATA B/P (data bits and parity)** – You can set data bits to 7 or 8 data bits per character. You can set parity to odd, even, or no parity (not checked). For example, 8N means 8 data bits per character and parity not checked. The LA100, LQP02, and LA50 printers are set up for 8 data bits and no parity when shipped.
2. **XMT/RCV BAUD (transmit/receive baud rate)** – You can set the rate at which the Rainbow computer sends data to its printer and the rate at which it receives status information from its printer. The LA100, LQP02, and LA50 printers are set for a baud rate of 4,800 when shipped.

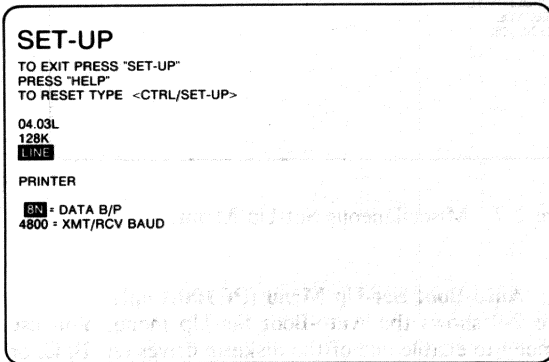

Figure 2-6 Printer Set-Up Menu

2.2.5 Miscellaneous Set-Up Menu

Three features compose the Miscellaneous (Misc) Set-Up menu, shown in Figure 2-7:

1. **SCROLL RATE** – You select 1, 2, or 3. Three is the fastest scroll rate.
2. **BELL VOL** – You select a volume level between 1 and 8. Eight is the loudest bell volume.
3. **CLICK VOL** – You select a volume level between 1 and 8. Eight is the loudest keyclick volume.

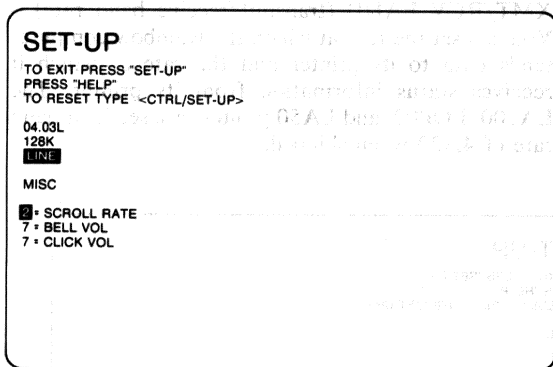

Figure 2-7 Miscellaneous Set-Up Menu

2.2.6 Auto-Boot Set-Up Menu (PC100B only)

Figure 2-8 shows the Auto-Boot Set-Up menu. You use this menu to enable one of the diskette drives (A, B, C, or D) or a hard disk drive (W) to load the operating system automatically. The default (represented by a "?" on your screen) is no device selected.

NOTE

"W = start from Drive W" is not available on the PC100A or the PC100A with the Winchester upgrade kit.

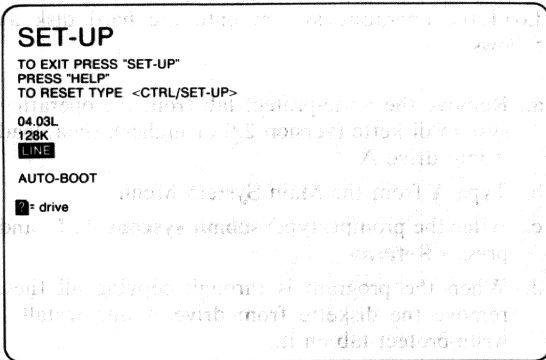

Figure 2-8 Auto-Boot Set-Up Menu (PC100B only)

Enabling Auto-Boot from the Hard Disk Drive – To load the CP/M-86/80 operating system onto the hard disk to boot automatically, perform the following steps.

1. If desired, repartition the hard disk as follows.
 - a. Load the Rainbow Hard Disk Utility Program diskette into drive A.
 - b. Type **A** from the Main System Menu.
 - c. Type **2** and press the **Do** key to repartition the hard disk.
 - d. Follow the instructions on the screen.
2. Select Auto-Boot Partition as follows.
 - a. From the Main Menu of the Rainbow Hard Disk Utility Program diskette, type **6** and press the **Do** key to select Auto-Boot Partition.
 - b. Type **1** and press the **Do** key to enable auto-boot from drive E (the hard disk drive).
 - c. Press <Set-Up> and <Ctrl/Set-Up> to reset the computer.

3. Load the operating system onto the hard disk as follows.
 - a. Remove the write-protect tab from the operating system diskette (version 2.0 or higher); then, load it into drive A.
 - b. Type **A** from the Main System Menu.
 - c. After the prompt, type: **submit syscopy A: E:** and press **<Return>**.
 - d. When the program is through copying all files, remove the diskette from drive A and install a write-protect tab on it.

4. Change Set-Up to boot from hard disk drive as follows.
 - a. Press **<Set-Up>** and **<Prev Screen>** to access the Auto-Boot Set-Up menu.
 - b. Press the **◀** key to display:
W = drive
 - c. Press **<Shift/S>** to save this selection.
 - d. Press **<Ctrl/Set-Up>** to reset the computer.

2.2.7 Memory Set-Up Menu (PC100A only)

The Memory Set-Up menu is shown in Figure 2-9. This value should reflect the total amount of memory in the system (64K, 128K, or 256K bytes). (In the PC100B version of the Rainbow computer, this feature is automatic.)

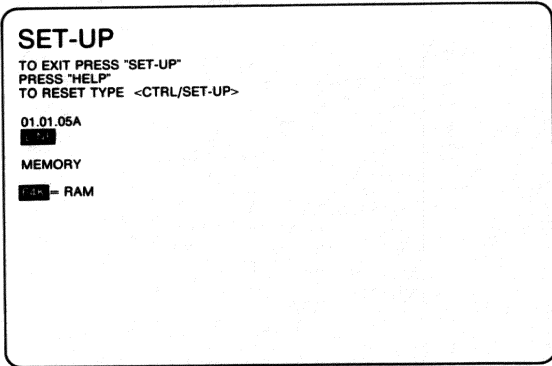

Figure 2-9 Memory Set-Up Menu (PC100A only)

3.2.7 Memory Set-Up Menu (PC100A only)
 The Memory Set-Up menu is shown in Figure 2. This value should reflect the total amount of memory in the system (64K, 128K, or 256K bytes). In the PC100B version of the Rainbow computer, this feature is automatic.

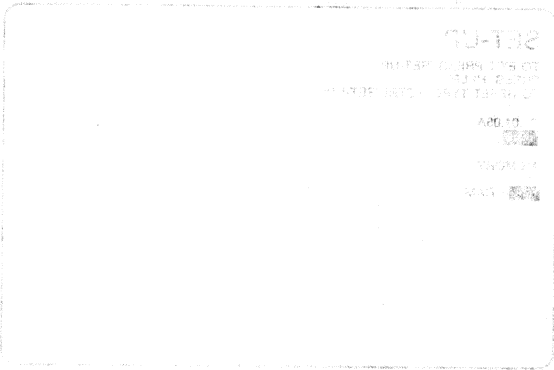

Figure 2 Memory Set-Up Menu (PC100A only)

3 TESTING AND TROUBLESHOOTING

3.1 INTRODUCTION

The Rainbow computer's diagnostic tests check almost every part of the system. The diagnostic tests check the internal circuitry of the system: the processors, memory, diskette controller, diskette drives, video control logic, and so on. In addition, there are diagnostic tests that help you check the keyboard, the monitor, the printer, and the connection to a host computer system.

3.2 TESTING STRATEGY

The power-up test runs every time you turn the Rainbow computer on. If the test detects an error, it displays an error message on the screen. The computer also displays an error code on the lights on the back panel of the system unit as shown in Figure 3-1.

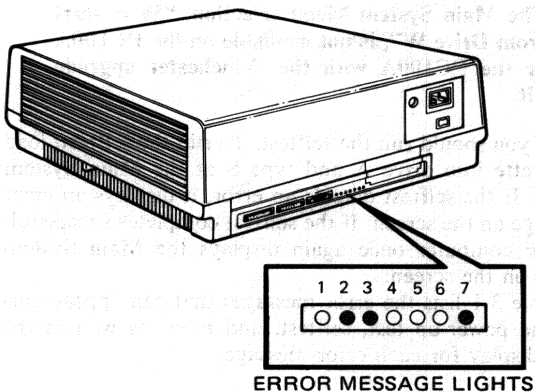
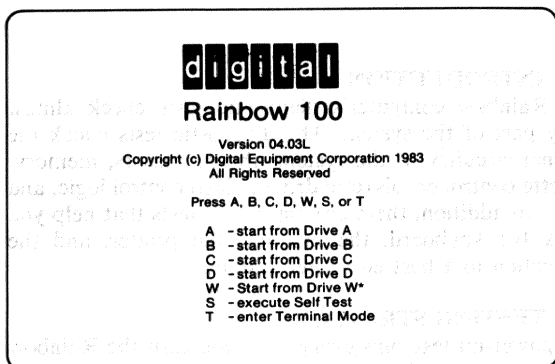

Figure 3-1 Diagnostic Error Message Lights

If the power-up test completes successfully, the computer displays the Main System Menu on the screen. (See Figure 3-2.)



*not on PC100A

Figure 3-2 Rainbow Main System Menu

NOTE

The Main System Menu selection, "W = start from Drive W", is not available on the PC100A or the PC100A with the Winchester upgrade kit.

Next, you should run the selftest. To run the selftest, load a diskette into drive A and type S at the Main System Menu. If the selftest detects an error, it displays an error message on the screen. If the selftest completes successfully, the computer once again displays the Main System Menu on the screen.

Table 3-1 lists the error messages that can appear during the power-up test, selftest, and reset, as well as the light display for each error message.

NOTE

The words in brackets in the message column are those that the PC100A version of the computer displays.

The paragraphs that follow Table 3-1 describe some possible causes of the error messages listed in the table and ways to correct them. After each message, Table 3-1 also lists the page of this guide you should see for more information.

Table 3-1 Internal Diagnostic Test Messages

Message Number	Message	Tested During:				Light Display 1 2 3 4 5 6 7	Fatal	See Page
		Power-Up	Reset	Self-test				
1	Main Board [video]	Yes	No	Yes	0 ● ● ● ● ● ● ●	Yes	29	
2	Main Board* [unsolicited interrupt]	Yes	Yes	Yes	● ● ● ● ● ● ●	Yes	30	
3	Drive A (or B) [index]	No	No	Yes	0 0 ● ● ● ● ● ● ●	No	26	
4	Drive A (or B) [motor]	No	No	Yes	● ● ● ● ● ● ● ● ●	No	26	
5	Drive A (or B) [seek]	No	No	Yes	0 ● ● ● ● ● ● ● ● ●	No	26	
6	Drive A (or B) [read]	No	No	Yes	● ● ● ● ● ● ● ● ●	No	26	

NOTES:

● = on, 0 = off, - = on or off;
Cond. = conditional.

*These errors can occur at any time because their circuits are monitored constantly.

Table 3-1 Internal Diagnostic Test Messages (Cont)

Message Number	Message	Tested During:			Self-test	Fatal	See Page
		Power-Up	Reset	Light Display			
				1 2 3 4 5 6 7			
7	Drive A (or B) [restore]	Yes	No	0 ● ● ● ● ● ● ● ●	No	26	
8	Drive A (or B) [step]	Yes	No	● 0 ● 0 ● 0 ● ● ● ●	No	26	
9	System Load Incomplete [system load]	Not	No	0 0 0 0 0 0 0 0 0 0	No	32	
10	Main Board [video, vfr]	Yes	No	● ● ● ● ● 0 ● ● ● ●	Yes	29	
11	System Load Incomplete [boot load]	Not	No	0 0 0 0 0 0 0 0 0 0	No	32	
12	Drive A (or B) [not ready]	No	No	0 0 0 0 0 ● ● ● ● ●	No	27	
13	Keyboard	Yes	Yes	● ● ● ● ● 0 ● ● ● ●	Yes	28	
14	Main Board [nvram data]	Yes	No	● ● ● ● ● 0 ● ● ● ●	No	29	

16	Interrupts Off*	Yes	Yes	Yes	●●●●●●●●	Cond.	28
17	Main Board [video ram]	Yes	Yes	Yes	●●●●●●●●	Yes	29
18	Main Board [Z80 crc]	Yes	Yes	Yes	●●●●●●●●	Yes	29
19	Main Board [ram 0-64K]	Yes	Yes	Yes	- - - ●●●●	Yes	29
20	Main Board* [unsolicited interrupt, Z80]	Yes	Yes	Yes	●●●●●●●●	Yes	29
21	Drive Not Ready	Not	No	No	●●●●●●●●	No	27
22	Remove Card or Diskette	Yes	Yes	Yes	●●●●●●●●	No	31
23	Non-System Diskette	Not	No	No	●●●●●●●●	No	30

NOTES:

● = on, ○ = off, - = on or off;

Cond. = conditional.

*These errors can occur at any time because their circuits are monitored constantly.

†These messages may occur during power-up if auto-boot is selected.

Table 3-1 Internal Diagnostic Test Messages (Cont)

Message Number	Message	Tested During:			Self-test	Light Display 1 2 3 4 5 6 7	Fatal	See Page
		Power-Up	Reset	Power-Up				
24	New Memory Size = nnnK	Yes	No	No	0 0 0 0 0 0 0	No	30	
25	Set-Up Defaults Stored	Yes	Yes	Yes	0 ● ● ● 0 0 0 ● ●	No	31	
26	Main Board [ram arbitration]	Yes	No	Yes	● ● ● ● 0 0 0 0 0	Yes	29	
27	Memory Board [ram option]	No	No	Cond.	- - - ● ● ● 0 0 0	No	30	
28	RX50 Controller Board	Yes	No	Yes	● ● ● ● 0 0 0 ● ●	No, but you cannot use a diskette; use terminal mode only	31	
29	Main Board* [Z80 response]	Yes	Yes	Yes	● ● ● ● 0 0 0 0 0	No	29	
30	Main Board [rom crc, rom 0]	Yes	No	Yes	● ● ● ● ● ● ● ● ● ●	Yes	29	

31	Main Board [rom crc, rom 1]	Yes	No	Yes	••••••••	Yes	29
	Main Board, rom crc, rom 2	Yes	No	Yes	••••••••	Yes	29
33	Main Board [contention]	Yes	No	Yes	••••••••	Yes	29
40	Main Board [printer port]	Yes	No	Yes	••••••••	No, but you cannot use the printer	30
50	Main Board [keyboard port]	Yes	No	Yes	••••••••	Yes	29
60	Main Board [comm. port]	Yes	No	Yes	••••••••	No, but terminal mode is not operational	30

NOTES:

• = on, o = off, - = on or off;

Cond. = conditional.

*These errors can occur at any time because their circuits are monitored constantly.

**Drive A (or B) - Message 3 [index]*
Message 6 [read]***

The diskette is write-protected, is inserted incorrectly in the drive, or is for a different computer. Reinsert the diskette; then, run the selftest program again. If the message persists, insert another diskette into the drive and run the selftest program again.

Make sure the drive cables are installed properly. If the message still occurs, replace the parts in the following order:

- Diskette drive
- Diskette drive cable
- RX50 controller module

Drive A (or B) - Message 4 [motor]*

The diskette may be bent and slowing down the motor, or the motor may be running too fast. Check the diskette for creases, smears, or dirt. Try another diskette in the drive and run the selftest again. If the problem persists after trying several diskettes, replace the diskette drive.

Drive A (or B) - Message 5 [seek]*

The diskette may be unformatted. Insert another diskette into the drive; then, run the selftest again. If the problem persists after trying several diskettes, make sure that the diskette drive cables are installed correctly. If the problem still persists, replace the diskette drive.

**Drive A (or B) - Message 7 [restore]*
Message 8 [step]***

Make sure that the diskette drive cables are installed correctly. If the problem still persists, exchange the parts in the following order.

- Diskette drive
- Diskette drive cable
- RX50 controller module

Drive A (or B) – Message 12 [not ready]*

The computer displays this message when you run the selftest program if any of the following occur.

- There is no diskette in the specified drive. To correct the problem, insert a diskette into the drive.
- The diskette is upside-down in the drive. To correct the problem, reinsert the diskette into the drive.
- The drive door is not closed. To correct the problem, close the drive door.

Run the selftest program again after correcting the problem. If the problem persists, make sure that the diskette drive cables are installed correctly. If the problem still persists, replace the diskette drive.

Drive Not Ready – Message 21

The computer displays this message when you start the operating system if any of the following occur.

- There is no diskette in the specified drive. To correct the problem, insert a diskette into the specified drive.
- The diskette is upside-down in the drive. To correct the problem, insert the diskette correctly into the drive.
- Drive C, D, or W is specified on a computer with drives A and B only. To correct the problem, specify drive A or B.
- The drive door is not closed. To correct the problem, close the drive door.

If the problem still persists, run the selftest to see if Message 12 occurs; then, follow the recommended corrective steps for Message 12.

* The words in brackets after the message number are those that the PC100A version of the Rainbow computer displays on the screen.

Interrupts Off – Message 16

The computer displays this message when you turn on the Rainbow computer or while you run an application program. This message is displayed in three ways.

1. If the message appears alone on the screen (a fatal message), turn the computer off and then on again. If the error persists after several retries, replace the system module.
2. If the message appears above the Main System Menu (a nonfatal message), turn the computer off and then on again. If the problem persists after several retries, replace the system module.
3. If the computer displays the message while it is running an application program, you should remove the application program diskette from the drive and turn the computer off and then on again.

If the computer does not display the message when you turn the computer on, rerun the application program. If the computer displays the message while rerunning the program, report the problem to the vendor of the application program or, if you wrote the program, check the program for a “bug” that has turned the interrupts off.

Keyboard – Message 13

The computer displays this message when you turn it on if the keyboard is not connected, a key is depressed, or the keyboard is not working properly. To correct the problem, check the following; then, turn the computer off and on again.

- Make sure you do not press any keys while the computer is going through power-up or reset.
- Make sure that the keyboard cable is secured to the back of the monitor and to the bottom of the keyboard.
- Check for any keys that may be stuck by running your fingers over the top of the keyboard keys.
- Make sure video connector (VIDEO) is securely connected.

If the problem persists after several retries, replace the keyboard.

Main Board - Message 1 [video]
Message 10 [video, vfr]
Message 17 [video ram]
Message 18 [Z80 crc]
Message 19 [ram 0-64K]
Message 20 [unsolicited interrupt, Z80]
Message 26 [ram arbitration]
Message 33 [contention]
Message 50 [keyboard port]

Turn the computer off and then on again. If the problem persists after several retries, replace the system module.

Main Board - Message 14 [nvm data]

The computer displays this message when you turn it on if the previous Set-Up selections are not read correctly. The Set-Up selections that were previously saved are not in effect.

Have the customer review the Set-Up selections, recall default settings by pressing <Shift/D>, and save them by pressing <Shift/S>. Turn the computer off and then on again. If the problem persists after several retries, replace the system module.

Main Board - Message 29 [Z80 response]

The computer displays this message when you turn it on or when you start the operating system. Turn the computer off, then on again. Make sure you are not using a VT180 system diskette. Insert another Rainbow operating system diskette into the drive and start again. If the problem persists after several retries, replace the system module.

Main Board - Message 30 [rom crc, rom 0]
Message 31 [rom crc, rom 1]
[rom crc, rom 2]

Turn the computer off, then on again. If the problem persists after several retries, replace the system module.

Main Board - Message 40 [printer port]

The computer displays this message when you turn it on if the printer connector (PRINTER) is not working properly. Turn the computer off and then on again. If the error persists after several retries, replace the system module.

Main Board - Message 60 [comm. port]

The computer displays this message when you turn it on if the communications connector (COMM) is not working properly. Turn the computer off and then on again. If the problem persists after several retries, replace the system module.

Main Board - Message 2 [unsolicited interrupt]**Memory Board - Message 27 [ram option]**

The computer could display either of these messages when the selftest finds a problem in the optional memory board.

Using the Rainbow diagnostic diskette, select the Individual Test Menu and run subtest 1, Memory (8088). If the problem persists, reseal the optional memory board and run the same subtest. If the error still persists, try to isolate the problem to a specific chip using Appendix B of this guide.

New Memory Size = nnnK - Message 24

If you have just installed or removed additional memory, the system displays this message only once when you first turn on the Rainbow computer. Confirm that the number (nnnK) is the correct amount of memory. If the message appears and you have not installed or removed memory, make sure that the memory board is not loose.

Non-System Diskette - Message 23

The computer displays this message when you start the operating system if the diskette in the drive is not the system diskette. To correct the problem, insert a system diskette into a drive and start the operating system again.

Remove Card or Diskette – Message 22

The computer displays this message when you turn on the Rainbow computer if:

- The protective card is in the drive and the drive door is closed. To correct the problem, remove the protective card.
- The diskette is upside-down or inserted incorrectly in the drive and the drive door is closed. To correct the problem, remove the diskette. Insert the diskette correctly; then, turn the computer off and then on again.

RX50 Controller Board – Message 28

Turn the computer off and then on again. If the problem persists after several retries, remove the RX50 controller board and insert it again. (It may have loosened from the system module.) If the problem still persists, replace the RX50 controller board.

Set-Up Defaults Stored – Message 25

The computer displays this message when you turn it on to indicate that a problem was found and corrected in the part of the computer that saves your Set-Up selections. If you receive this message, you are at the language selection menu. The Set-Up selections that you have previously saved are not in effect; the default Set-Up selections (those set at the factory) are in effect. The message is informative only.

Reset and save the Set-Up selections you require.

**System Load Incomplete – Message 9 [system load]
Message 11 [boot load]**

The computer displays this message when you start the operating system if any of the following occur.

- The diskette is write-protected and is upside-down in the drive. To correct, insert the diskette correctly in the drive.
- The diskette in the drive is not a Rainbow operating system diskette. To correct, insert a Rainbow operating system diskette in the drive.
- The operating system program on the diskette is unreadable.
- The diskette is blank and unformatted.

Restart the operating system. If the problem persists, insert another operating system diskette into the drive and restart the operating system.

If the selftest runs successfully, run Test Drives A and B, described in Paragraph 3.3.1, from the Rainbow diagnostic diskette menu. Because the RX50 diskette drives contain most of the moving parts in the system, a problem can be expected more often with the diskette drives than with the rest of the system.

Generally, you will find the trouble by running these tests. However, if the power-up test, selftest, and the Test Drives A and B all run successfully, run the Test Computer selection, described in Paragraph 3.3.2, from the Rainbow diagnostic diskette menu. The Test Computer selection is a collection of individual tests that run one after the other. It takes about 30 minutes to run, but you can depend on this selection to detect most hardware faults. After the Test Computer selection finds the trouble and you replace the failing part, do not run the entire test again to verify the fix. Run the one test that found the trouble from the Display Individual Test Menu described in Paragraph 3.3.3.

When you know generally where a problem is, run one or more of the relevant individual tests described in Paragraph 3.3.3. For example, if the system runs well but cannot print on the printer, run selftest, the comm/printer/keyboard port test, comm/printer external loopback test, and the printer confidence test.

After you install a new part, verify proper operation by running selftest and any appropriate individual tests.

3.3 DIAGNOSTIC DISKETTE TESTS

To start the diagnostic diskette, insert it into drive A and type A at the Main System Menu. You can also start the diagnostic diskette from drives B, C, or D. Figures 3-3 and 3-4 show how to insert the diskettes in drives A or C and B or D, respectively. The Main Diagnostic Menu, shown in Figure 3-5, will be displayed. You can select the tests described in the following text from this menu. You must have two good blank diskettes to run selection 1 or 2 from this menu. Table 3-2 lists the diagnostic test messages that will display if a problem occurs and also suggests corrective action.



Figure 3-3 Inserting Diskette in Drive A or C

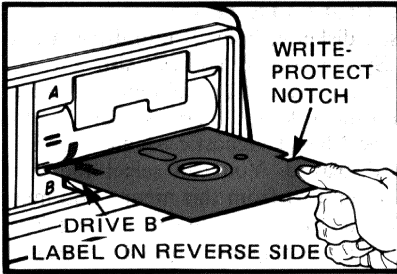

Figure 3-4 Inserting Diskette in Drive B or D

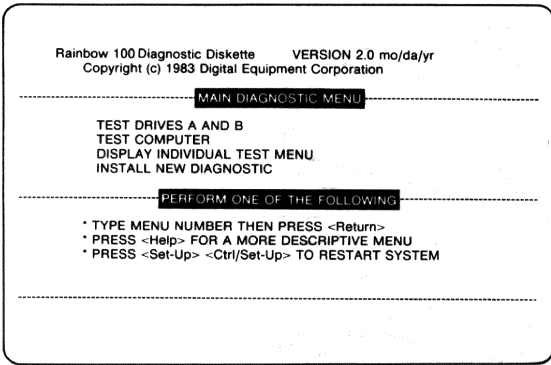

Figure 3-5 Main Diagnostic Menu

Table 3-2 Diagnostic Test Messages

Messages	Possible Source/ Corrective Action
Diagnostic Executive Messages	
SYSTEM ERROR: COMPUTER CANNOT FIND SUFFICIENT MEMORY	Diagnostic diskette or system module. Try another diskette. Replace system module.
SYSTEM ERROR: DISK READ OR WRITE FAILED RESTART SYSTEM	Diagnostic diskette, diskette drive, or system module. Try another diskette. Replace system module.
SYSTEM ERROR: COMPUTER CANNOT READ TEST FILE FROM THE DISK	Diagnostic diskette. Try another diskette.
SYSTEM ERROR: COMPUTER CANNOT READ MESSAGE FILE FROM THE DISK	Diagnostic diskette. Try another diskette.
SYSTEM ERROR: COMPUTER NOT RUNNING CORRECTLY	Try another diagnostic diskette. Replace system module.
Memory (Set-Up) Test Messages	
FAILURE: MAIN BOARD: SET-UP MEMORY DOES NOT STORE DATA CORRECTLY	Make sure memory board is installed correctly.
FAILURE: MAIN BOARD: MEMORY STORES DATA INCORRECTLY	System module. Replace system module.
FAILURE: MAIN BOARD: CANNOT COPY SET-UP MEMORY	System module. Replace system module.
FAILURE: OPTION MEMORY BOARD: MEMORY STORES DATA INCORRECTLY	Optional memory board component. See Appendix B for corrective action.

Table 3-2 Diagnostic Test Messages (Cont)

Messages	Possible Source/ Corrective Action
Memory (8088) Test Messages	
FAILURE: MAIN BOARD: INVALID SET-UP DATA FOR OPTIONAL MEMORY	System module. Replace system module.
ERROR: OPTION MEMORY BOARD PRESENT; SET-UP SHOWS IT IS NOT PRESENT	Memory size is incorrect. Make sure memory board is installed correctly. Check memory size.
ERROR: OPTION MEMORY BOARD NOT PRESENT; SET-UP SHOWS IT PRESENT	Memory size is incorrect. Make sure memory board is installed correctly. Check memory size.
SYSTEM ERROR: COMPUTER CANNOT FIND SUFFICIENT MEMORY	System module. Replace system module.
SYSTEM ERROR: SYSTEM CLOCK DOES NOT WORK	System module. Replace system module.
ERROR: SET-UP FOR MEMORY SIZE IS NOT CORRECT	Memory size is incorrect. Make sure memory board is installed correctly.
FAILURE: MEMORY OPTION BOARD: PARITY DETECTION DOES NOT WORK	Switch 4 on the memory board should be on; check switch. If problem persists, replace memory board.
FAILURE: OPTION MEMORY BOARD: OPTION MEMORY SIGNAL IS INCORRECT	Replace memory board.
FAILURE: OPTION MEMORY BOARD: MEMORY SIZING INCORRECT	Memory board component. See Appendix B for corrective action.
MEMORY TEST TERMINATED TEST CANNOT CONTINUE - PLEASE RESTART SYSTEM	Diagnostic diskette.

Table 3-2 Diagnostic Test Messages (Cont)

Messages	Possible Source/ Corrective Action
Memory (8088/Z80) Test Messages	
FAILURE: MAIN BOARD: MEMORY STORES DATA INCORRECTLY	System module. Replace system module.
SYSTEM ERROR: SYSTEM CANNOT FIND SUFFICIENT MEMORY	System module. Replace system module.
SYSTEM ERROR: TEST PRO- GRAM DOES NOT FUNCTION CORRECTLY	Diagnostic diskette.
Diskette System Error Messages	
FAILURE: MAIN BOARD: IL- LEGAL INTERRUPT TO Z80	Repeat test; if error per- sists, replace system mod- ule.
Z80 DIAGNOSTIC FILE NOT FOUND	Cannot find file on dis- kette.
FAILURE: MAIN BOARD: Z80 RESPONSE FAILURE	Repeat test; if message persists, replace system module.
SYSTEM ERROR: INSUFFI- CIENT MEMORY FOR DIAG- NOSTICS	Repeat test; if message persists, replace system module.
FAILURE: RX50 CONTROL- LER BOARD:	Bad connection between system module and RX50 controller module; remove and reseat controller mod- ule. Run test again; if message persists, replace RX50 controller module.
FORCED LOST DATA (read)	
FORCED LOST DATA (write)	
FORCED RECORD NOT FOUND (read)	
FORCED RECORD NOT FOUND (write)	
FORCED SEEK	
HEAD LOAD TIMING	

Table 3-2 Diagnostic Test Messages (Cont)

Messages	Possible Source/ Corrective Action
INTERNAL REGISTER	Bad connection between system module and RX50 controller module; remove and reseal controller module. Run test again; if message persists, replace RX50 controller module.
LOOP BACK READ	
MOTOR SHUT OFF	
NO TRACK GREATER THAN 43 SIGNAL	
RESTORE	
SEEK FAILURE (with no verify)	
WRITE SECTOR	Could be a bad diskette; try another diskette and run test again. If message persists, remove and reseal RX50 controller module; if error still persists, replace RX50 controller module.
FAILURE: RX50 CONTROLLER BOARD: WRITE SECTOR	
FAILURE: DRIVE X (where X = A, B, C, or D) - DRIVE NOT READY	Diskette is not inserted properly or is upside-down; diskette drive door is open.
INDEX PULSE	Diskette may be upside-down or is not spinning.
SEEK (with verify)	Could be a bad diskette; rerun test using another diskette.
READ SECTOR	May occur after a write sector failure. Could be a bad diskette; try another diskette.
WRITE SECTOR	Could be a bad diskette; try another diskette.
DISKETTE WRITE PROTECTED	Write-protect tab is on diskette.

Table 3-2 Diagnostic Test Messages (Cont)

Messages	Possible Source/ Corrective Action
<p>NOTE The following diskette drive error messages may occur from poor connection between the RX50 controller module and the diskette drive. Reseat cables and rerun tests. If any of these errors persist, remove and replace the diskette drive.</p>	
<p>FAILURE: DRIVE X (where X = A, B, C, or D) - RESTORE</p>	<p>No track 0 signal coming from drive; insert and remove protective card; try again; replace diskette drive.</p>
<p>STEP</p>	<p>Head did not move in correct amount of time; insert and remove protective card; try again; replace diskette drive.</p>
<p>MOTOR SPEED</p>	<p>Diskette drive motor is turning too fast or too slow; diskette may be warped, try another; replace diskette drive.</p>
<p>STEP-IN</p>	<p>Head did not move toward spindle correctly; replace diskette drive.</p>
<p>STEP-OUT</p>	<p>Head did not move away from spindle correctly; replace diskette drive.</p>
<p>MULTI-TRACK TIMING</p>	<p>Head did not move away from spindle correctly; replace diskette drive.</p>

Table 3-2 Diagnostic Test Messages (Cont)

Messages	Possible Source/ Corrective Action
Memory (Z80) Test Error Messages	
SYSTEM ERROR: CANNOT LOAD Z80 TEST PROGRAM FROM DISKETTE	Diagnostic diskette.
SYSTEM ERROR: TEST DOES NOT FUNCTION CORRECTLY	Diagnostic diskette or sys- tem module.
FAILURE: MAIN BOARD: Z80 FAILED TO START MEMORY TEST	System module. Replace system module.
FAILURE: MAIN BOARD: Z80 FAILED TO COMPLETE MEM- ORY TEST	System module. Replace system module.
FAILURE: MAIN BOARD: Z80 PRIVATE MEMORY DOES NOT STORE DATA CORRECTLY	System module. Replace system module.
FAILURE: MAIN BOARD: Z80 CANNOT COPY DATA TO SHARED (Z80/8088) MEMORY	System module. Replace system module.
FAILURE: MAIN BOARD: Z80 CANNOT RESTORE DATA TO Z80 PRIVATE MEMORY - TEST CANNOT CONTINUE, PLEASE RESTART SYSTEM -	Reboot system and try again; if problem persists, replace system module.
FAILURE: MAIN BOARD: Z80 DID NOT EXECUTE THE TEST CORRECTLY	Diagnostic diskette or sys- tem module.

Table 3-2 Diagnostic Test Messages (Cont)

Messages	Possible Source/ Corrective Action
System Interaction Error Messages	
FAILURE: MAIN BOARD: I/O ERROR COMM CHANNEL (A) ERROR PRINTER KEYBOARD PORT ERROR DISKETTE WRITE ERROR SYSTEM ERROR	Retry test. If error persists, replace system module.
FAILURE: DRIVE B: WRITE ERROR	Try another diskette.
Z80 DIAGNOSTIC FILE NOT FOUND	Try another diagnostic diskette.
FAILURE: DISKETTE WRITE- PROTECTED	Remove write-protect tab.
Video Controller Test Error Messages	
FAILURE: MAIN BOARD: VIDEO ERROR VERTICAL RETRACE RATE	The vertical retrace rate is either too slow or too fast. Replace the system module.
FAILURE: MAIN BOARD: VIDEO ERROR A LOOPBACK CHECK IS INCORRECT	The information sent to the video output is being altered. Replace the system module.
Keyboard Test Error Message	
SYSTEM ERROR: KEY PROCESSING	Replace system module.

Table 3-2 Diagnostic Test Messages (Cont)

Messages	Possible Source/ Corrective Action
Winchester (Hard Disk) Diagnostic Error Messages	
The hard disk option is not connected.	The hard disk option is missing or is not seated correctly. Press the Help key for more information, then check inside the system unit.
	The hard disk controller or the cables may be loose. Check connections.
FAILURE: HARD DISK CONTROLLER: (followed by: DRIVE NOT SELECTED DRIVE NOT READY	Check the cables that connect from the drive to the controller.
FAILURE: HARD DISK CONTROLLER: R/W ERROR IN HEAD SELECT REGISTER	The hard disk controller is not seated firmly on the system module.
FAILURE: HARD DISK CONTROLLER: IMPROPER STATUS, COMMAND COMPLETION	Small connector on hard disk drive cable or 4-wire cable is not connected to disk drive.
FAILURE: HARD DISK CONTROLLER: (followed by: A SEEK COMMAND DID NOT RESULT IN THE CORRECT NUMBER OF STEP PULSES	Reseat the hard disk controller board and run the hard disk diagnostic again. If error persists, replace the hard disk controller board.
CONTROLLER STEPPING TOO FAST	
HEAD NOT POSITIONED OVER EXPECTED TRACK	

Table 3-2 Diagnostic Test Messages (Cont)

Messages	Possible Source/ Corrective Action
NO INTERRUPT ON COMMAND COMPLETION	Reseat the hard disk con- troller board and
R/W ERROR DETECTED IN REGISTER	run the hard disk diagnostic again.
R/W ERROR IN SECTOR BUFFER	If error persists, replace the hard disk controller board.
SECTOR BUFFER COUNTER FAILED TO CLEAR	
SEEK ATTEMPTED IN WRONG DIRECTION	
STATUS NOT PROPERLY SET AFTER ISSUING A COMMAND	
STEP FLAG NOT CLEARED/SET	
TRK00 NOT CLEARED AFTER A SEEK	
UNABLE TO CLEAR ERROR FLAG	
UNABLE TO FORCE ABORT ERROR	
UNABLE TO FORCE I.D. NOT FOUND	
UNABLE TO RESET INDEX LATCH	
UNEXPECTED RD51 INTERRUPT	
WRITE FAULT	

Table 3-2 Diagnostic Test Messages (Cont)

Messages	Possible Source/ Corrective Action
FAILURE: DRIVE: DRIVE NOT READY	Cable to hard disk drive or controller is loose or not fully seated. Check cable. The 4-wire power cable to hard disk drive is not connected. Check cable.
FAILURE: DRIVE: (followed by: DRIVE ROTATIONAL SPEED TOO SLOW/FAST HARD READ FAILURE, BAD SURFACE	Replace hard disk drive with a known good drive and run the test again. If error is still present, replace the drive cable.
SEEK COMPLETE NOT DETECTED AFTER WRITE FAULT	
TRACK 00 NOT DETECTED AFTER RESTORE OR SEEK TO TRACK 0	
TRACK 00 NOT FOUND ABORTED COMMAND	
FAILURE: CONTROLLER OR DRIVE?: DATA ERROR, BAD WRITE OR READ	Pin 3 on large connector of the hard disk drive cable is damaged. Remove the cable from the hard disk drive. If pin cannot be straightened, install a new cable.
FAILURE: CONTROLLER OR DRIVE? (followed by): CRC ERROR D.A.M. (data address mark) NOT FOUND HARD SCAN FAILURE	Check the hard disk controller and make sure it is firmly seated in its connectors. If error persists, replace the following components with known good components in the following sequence:

Table 3-2 Diagnostic Test Messages (Cont)

Messages	Possible Source/ Corrective Action
<p>HARD WRITE FAILURE</p> <p>I.D. NOT FOUND</p> <p>SLOW/FAST STEPPING RATE</p> <p>UNABLE TO SET INDEX LATCH</p>	<ul style="list-style-type: none"> • Hard disk drive cable • Hard disk drive • Hard disk controller
<p>FAILURE: MEDIA: BAD SECTOR DETECTED ON CYLINDER 0</p>	<p>Press the Help key and follow the instructions on the screen. Re-initialize the hard disk using the hard disk utility program. Run the diagnostic again. If failure still occurs, replace the disk drive.</p>
<p>FAILURE: CONTROLLER OR DRIVE?: (followed by) DIAGNOSTIC CYLINDER HAS INCORRECT DATA</p>	<p>Press the Help key and follow the instructions on the screen. Replace the parts in the following order:</p>
<p>HARD READ FAILURE</p>	<ul style="list-style-type: none"> • Hard disk drive cable • Hard disk drive • Hard disk controller

Table 3-2 Diagnostic Test Messages (Cont)

Messages	Possible Source/ Corrective Action
Extended Communications Option Internal Diagnostic Error Messages	
FAILURE: COMM OPTION BOARD	
(followed by:)	
COMM OPTION NOT INSTALLED	<ul style="list-style-type: none"> • Verify that option has been installed.
MPSC DATA BUS WRITING ZEROS	<ul style="list-style-type: none"> • Reseat COMM option by removing and installing it. • Rerun Ext Comm test. • If error persists, replace COMM option module.
DMA TERMINAL COUNT CHANNEL 0	<ul style="list-style-type: none"> • Make sure nothing is attached to COMM connectors. If there is, remove and rerun test.
DMA TERMINAL COUNT CHANNEL 2	
Ext. Comm A BUFFER COMPARE ERROR	<ul style="list-style-type: none"> • If error persists, reseat COMM option by removing and installing it.
Ext. Comm B BUFFER COMPARE ERROR	
SYNC DETECT Ext. Comm A	<ul style="list-style-type: none"> • Rerun test. If error persists, replace COMM option.
SYNC DETECT Ext. Comm B	

Table 3-2 Diagnostic Test Messages (Cont)

Messages	Possible Source/ Corrective Action
DMA REGISTER DATA TEST	<ul style="list-style-type: none"> • There is a hardware fault in the COMM option. Reseat option by removing and installing it.
DMA DIAGNOSTIC INTERRUPT	<ul style="list-style-type: none"> • Reseat option by removing and installing it.
COMMAND STATUS REGISTER RESET	<ul style="list-style-type: none"> • Rerun test.
COMMAND STATUS REGISTER READ	<ul style="list-style-type: none"> • If error persists, replace COMM option.
MPSC DATA BUS	
BAUD RATE GENERATOR	
Extended Communications Option External Diagnostic Error Messages	
FAILURE: COMM OPTION BOARD: (followed by): CARRIER SENSE	<ul style="list-style-type: none"> • Check that loopback plug is attached <u>only</u> to EXT COMM B connector.
CLOCK SUBSTITUTION	
COMM SIGNAL "DTR" TO "DSR"	<ul style="list-style-type: none"> • If not, attach plug and rerun test.
COMM SIGNAL "RTS" TO "CTS" & "BRLSD/CD"	<ul style="list-style-type: none"> • If error persists, reseat COMM option and rerun test.
COMM SIGNAL "SPSL" TO "RI"	
COMM SIGNAL "SRTS" TO "SI"	<ul style="list-style-type: none"> • If error persists, replace COMM option.
COUNT DONE	
DMA TERMINAL COUNT CHANNEL 0	

Table 3-2 Diagnostic Test Messages (Cont)

Messages	Possible Source/ Corrective Action
DMA TERMINAL COUNT CHANNEL 2	<ul style="list-style-type: none"> • Check that loopback plug is attached only to EXT COMM B connector.
Ext. Comm A BUFFER COMPARE ERROR	
Ext. Comm B BUFFER COMPARE ERROR	<ul style="list-style-type: none"> • If not, attach plug and rerun test.
MISSING IDLE DETECT	<ul style="list-style-type: none"> • If error persists, reseal COMM option and rerun test.
SYNC DETECT Ext. Comm A	
SYNC DETECT Ext. Comm B	<ul style="list-style-type: none"> • If error persists, replace COMM option.
UNEXPECTED IDLE DETECT	

Color/Graphics Option Error Messages

FAILURE: GRAPHICS OPTION:
(followed by:)

**GRAPHICS BOARD NOT
PRESENT**

Option is not detected
in the system.

- Verify that option has been installed.
- Reseat option board by removing and installing it.
- Rerun test. If error persists, replace option and rerun test.
- If error persists, error may be in the system module.

Table 3-2 Diagnostic Test Messages (Cont)

Messages	Possible Source/ Corrective Action
CHARACTER BUFFER	<ul style="list-style-type: none"> • Reseat color/graphics option by removing it, installing it, and rerunning test.
CLOCK TIMING	
CONTROLLER INVALID SYNCHRONIZATION	<ul style="list-style-type: none"> • If error persists, replace color/graphics option.
CONTROLLER OR ADDRESSING	
CONTROLLER OR DATA BUS	<ul style="list-style-type: none"> • Rerun test. If error persists, there is a hardware fault in the system module.
CONTROLLER RETURNS INVALID STATUS	
DATA BUS OR MEMORY	
ERRATIC INTERRUPT	
BACKGROUND/ REGISTER OR PLANE SELECT	
GRAPHICS MASK	
MEMORY DATA	
MEMORY REFRESH	
PATTERN REGISTER OR PATTERN MULTIPLIER	
PROGRAMMABLE LOGIC ARRAY	
SCROLL MAP OR DATA BUS	
TEXT MASK	

3.3.1 Test Drives A and B

The Test Drives A and B selection, on the Main Diagnostic Menu checks diskette drives A and B only. You select 4, Disk System from the Individual Test Menu, described in Paragraph 3.3.3, to check drives C and D.

3.3.2 Test Computer

The Test Computer selection on the Main Diagnostic Menu checks most of the basic Rainbow computer functions including extended memory. It does not check other options or the line drivers on each port. It is a collection of individual tests that run one after the other. The Test Computer selection takes about 30 minutes to run, so you should use it only when you cannot find the problem with some other shorter test. After the Test Computer selection finds the trouble and you replace the failing part, do not run the Test Computer selection again to verify the fix. Run the test that found the trouble from the Individual Test Menu described in Paragraph 3.3.3.

3.3.3 Display Individual Test Menu

The Display Individual Test Menu selection on the Main Diagnostic Menu displays a menu, shown in Figure 3-6, of the individual tests that are included in the Test Computer selection. In addition, there are tests that require loopback connectors and user interaction and there are tests that may be added by the customer for optional equipment.

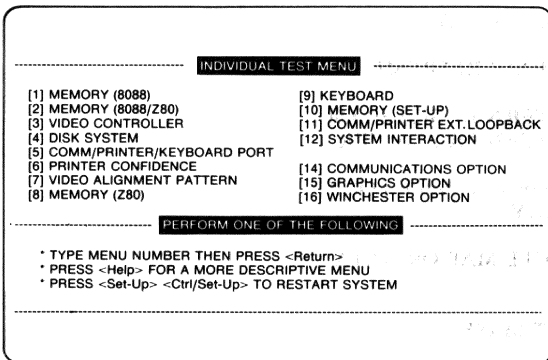

Figure 3-6 Individual Test Menu

The following paragraphs summarize the individual test selections. You can also press the **Help** key for additional information on each test.

1. **MEMORY (8088)** – The Memory (8088) test checks the memory including the optional memory board, if present. If you replace the memory board or add components to the memory board, you use this test to verify that the new memory board works correctly.
2. **MEMORY (8088/Z80)** – This test checks the memory that is shared between the two internal processors.
3. **VIDEO CONTROLLER** – This test checks the timing of the refresh signal, checks internal loopback signals, and displays each of the special video capabilities of the screen for 20 seconds. You must watch the screen to check these capabilities. To begin the displays, press the **Resume** key. To hold a display, press the **Interrupt** key. To continue to the next display, press the **Resume** key.
4. **DISK SYSTEM** – This diagnostic tests diskette drives A and B, C and D, or all of them. This performs the same test as the Test Drives A and B selection described in Paragraph 3.3.1; however, it allows you to test drives C and D also.
5. **COMM/PRINTER/KEYBOARD PORT** – This test checks all internal data transmission paths, except for the line driver circuits, on the system module. A loopback plug is not required for this test.
6. **PRINTER CONFIDENCE** – This test checks the printer. Press the **Escape** key. Type your test message on the keyboard, then press the **Escape** key again. To stop the test, press the **Escape** key again or press the **Return** key.
7. **VIDEO ALIGNMENT PATTERN** – This test fills the entire screen with E's to help you perform screen adjustments and check intensity, sizing, and spacing of characters. When the graphics option is present, this test produces a pattern with center cross hairs and corner marks that you can match with a transparent template (part number 29-24371-00).
8. **MEMORY (Z80)** – This test checks the 2K byte Z80A processor memory on the system module.

9. **KEYBOARD** – This test draws a keyboard on the screen with all of the keys on it. When you press a key, the screen will indicate whether or not the key works. Press the **Help** key for information on exceptions. To exit the test, type the letters **OUT**.
10. **MEMORY (SET-UP)** – This test checks the nonvolatile memory that is used for saving Set-Up selections after power is turned off.
11. **COMM/PRINTER EXTERNAL LOOPBACK** – This test checks the communications and printer circuits including the line drivers on the system module that could not be checked with selection 5. You must install a loopback plug on the **COMM** connector (part number 12-15336-01 for PC100A or 12-15336-04 for PC100B) and a loopback plug (29-24631-00) on the **PRINTER** connector before you can run this test.
12. **SYSTEM INTERACTION** – This test exercises all system tasks at once to check for timing problems. If an error is detected, the test reduces the number of tasks competing for system resources to detect the failure.
13. Not used.

NOTE

Tests 14, 15, and 16 are diagnostic tests that are shipped with each option. Using selection 4 from the Main Diagnostic Menu, you can add these tests to your Rainbow diagnostic diskette (version 2.0 or higher). You cannot add these tests to Version 1.0 of the diagnostic diskette (part numbers BL-T309A-BV and BL-T309B-BV). Therefore, if you have Version 1.0, run these tests from the diagnostic diskette that comes with the option.

14. **COMMUNICATIONS OPTION** – This selection contains the internal and external diagnostic tests that come with the extended communications option. A loopback plug (part number 12-15336-04) is required for the external diagnostic test. See Appendix C to run this test.
15. **GRAPHICS OPTION** – This selection contains the color/graphics diagnostic that comes with the color/graphics option. See Appendix D to run this test.

16. WINCHESTER OPTION – This selection contains the hard disk diagnostic (also on the Rainbow Hard Disk Utility Program diskette) that comes with the Winchester (hard disk) option. See Appendix E for more information on this program.

3.3.4 Install New Diagnostic Test

This selection is not a test but a feature that allows you to add the tests for each option to your diagnostic diskette. Each new option has a diskette with the diagnostic tests for that option. You use the Install New Diagnostic selection on the Main Diagnostic Menu to copy the new test to the Rainbow diagnostic diskette. Type **4**, press the **Return** key, and follow the instructions on the screen. To select the test for a particular option, display the Individual Test Menu (Figure 3-6), type the number of the test (14, 15, or 16), then press the **Return** key.

NOTE

You cannot use this feature if you have an early Rainbow diagnostic diskette (part numbers BL-T309A-BV or BL-T309B-BV).

3.4 EXITING A DIAGNOSTIC

To return to the Main System Menu from a diagnostic program, follow the instructions on the screen. If the program stops and does not display a failure message, note the diagnostic section and the hardware configuration; then, report the problem to the Digital Customer Help Line, 800-DEC-8000. Reset the computer by entering Set-Up and pressing **<Ctrl/Set-Up>**. If you cannot enter Set-Up, you have to set the power switch to 0 then back to 1.

3.5 DISKETTE CARE

Diskettes can be easily damaged but are very durable when you handle them properly. To ensure long diskette life, observe the following guidelines.

- Remove diskettes from the drives before turning the system power off.
- Do not bend the diskettes.
- Do not touch the diskette surface through the slots shown in Figure 3-7. Skin oils can cause the drive to produce data errors.

- Always return diskettes to their protective paper envelopes even if you expect to use them again in a few seconds. One piece of grit on a diskette can destroy critical data.
- Do not batter or bang your diskettes. Keep them in their plastic case.
- Do not write on the diskette label with a ball-point pen or a pencil; this may dent the diskette. Use felt tip pens.
- Watch out for magnets. They can destroy data on your diskette.
- Replace diskettes when they get old.

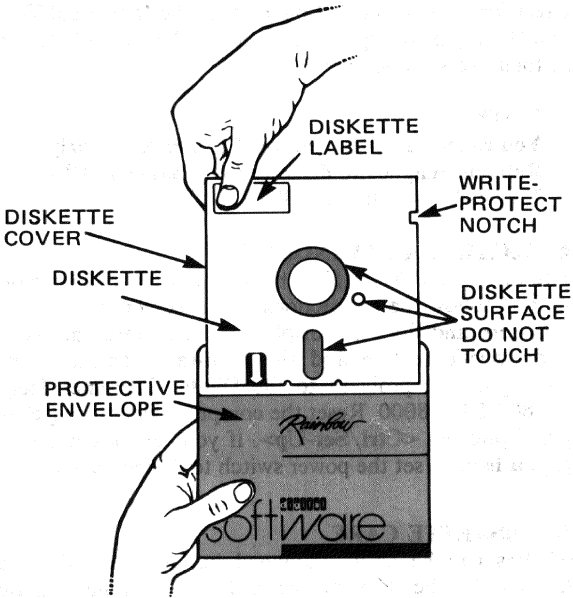

Figure 3-7 Diskette Care

4 MONITOR ADJUSTMENTS

4.1 INTRODUCTION

This chapter discusses general adjustments to the black and white video monitor, VR201, as well as specific adjustments if it is used with the color/graphics option.

For all adjustments to your color video monitor, VR241-A, refer to the *VR241 Color Video Monitor Pocket Service Guide* (EK-VR241-PS) for details.

4.2 PREPARATION

Before you can make any adjustments to the monitor, you must perform the following steps.

1. Set the power switch on the system unit to 0 (off) and unplug the cables from the back of the monitor.
2. Place some protective material over the screen to protect it from scratches.
3. If your monitor is equipped with a tilt foot, extend it.

CAUTION

If the tilt foot is not fully extended, it will catch on the internal wires of the monitor when you remove the cover.

4. Place the monitor face down on a flat surface.
5. Remove the screw cap from the back of the monitor (Figure 4-1).
6. Unscrew the cover retaining screw and remove it (Figure 4-1).
7. Slide the cover off and place it to one side.

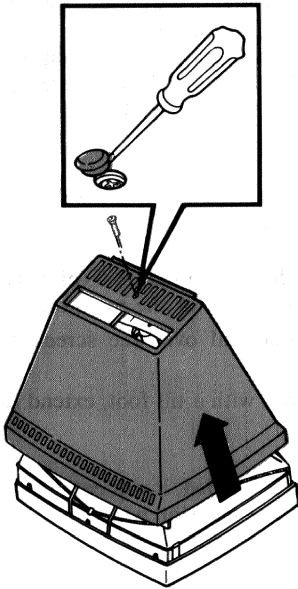

Figure 4-1 Monitor Cover Removal

WARNING
SOURCES OF HIGH VOLTAGE

The monitor holds a charge of over 12,000 V even with the power off. Therefore, when adjusting the monitor, use extreme care, especially around the following parts, shown in Figure 4-2.

- Anode and anode wire
- Flyback transformer
- Connector at neck of CRT

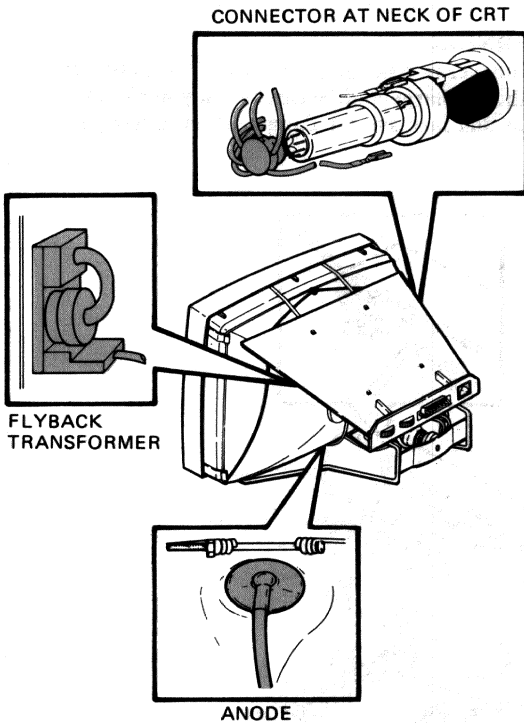

Figure 4-2 Sources of High Voltage

8. Discharge the anode connection of the CRT by performing the following steps.

NOTE

The high voltage at the anode will normally discharge by itself over a short period of time when the power is turned off; however, this discharge procedure is necessary in case there is a problem in the high voltage power supply on the monitor module that prevents it from discharging by itself.

- a. Clip the anode discharge tool to the wire frame of the monitor assembly as shown in Figure 4-3.

WARNING

Do not scratch the glass of the CRT with the tip of the discharge tool. Scratches may weaken the glass and increase the danger of an implosion.

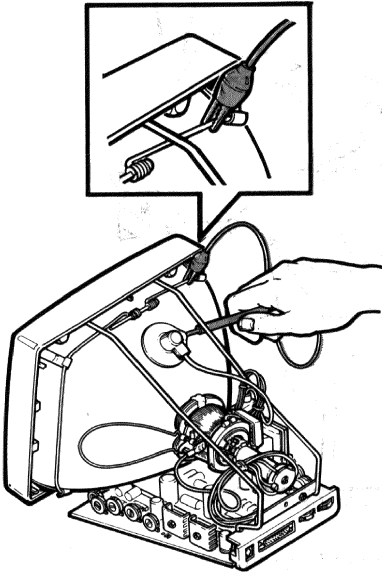

Figure 4-3 Discharging the CRT Anode

- b. Slide the tip of the anode discharge tool or test probe under the rubber boot as shown in Figure 4-3. Hold for a full 3 seconds.
9. Return the monitor to its normal operating position.

WARNING

Place the monitor on a nonconductive surface to avoid any electrical shorts.

10. Remove the protective material from the screen.
11. Reconnect all cables to the back of the monitor (Figure 4-4), and set the power switch to 1 (on).
12. Load the Rainbow diagnostic diskette and select the Display Individual Test Menu from the Main Diagnostic Menu (see Paragraph 3.3). If you have a color/graphics option installed, load the GSX-86 diskette and select the Graphics Option Hardware Diagnostic Test.

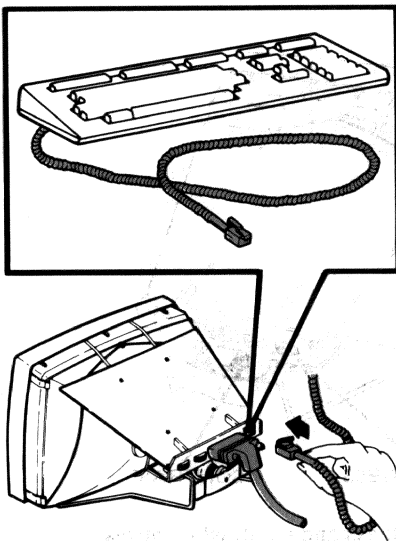

Figure 4-4 Connecting the Monitor for Adjustments

13. Select the video (or monitor) alignment pattern. The video alignment pattern will fill the screen with E's. The graphics monitor alignment pattern will create a crosshatch pattern on the screen.

4.3 ADJUSTMENTS

Whenever you make any adjustment, make sure the following Set-Up conditions exist.

- 80 column screen width (not 132 columns)
- Dark screen (white characters on a dark background)

The procedure for changing the Set-Up features is explained in Chapter 2, Set-Up Features.

4.3.1 Brightness and Contrast

Use the following procedure to adjust brightness and contrast.

1. Turn the brightness and contrast controls to the minimum setting (Figure 4-5).

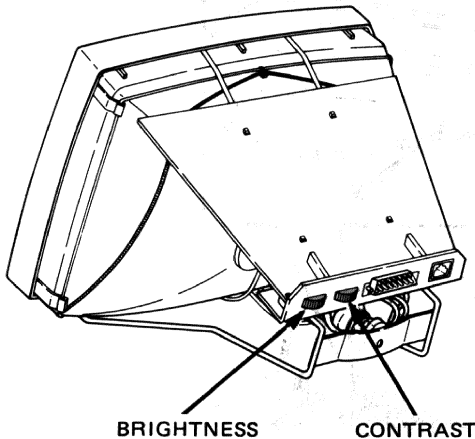

Figure 4-5 Brightness and Contrast Controls

2. Increase the brightness control until the raster appears; then, decrease it just until the raster disappears.
3. Set the contrast control for easy viewing.

4.3.2 Vertical Hold (VH)

Use the following procedure to adjust the vertical hold.

1. Examine the monitor display for rolling or any other sign of vertical instability.
2. If needed, adjust the vertical hold (VH) control (Figure 4-6) to stop any vertical movement.

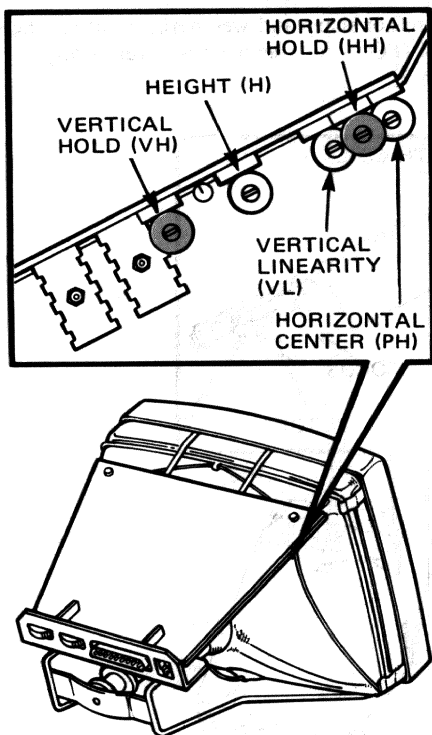

Figure 4-6 Vertical and Horizontal Hold Controls

4.3.3 Horizontal Hold (HH)

Use the following procedure to adjust the horizontal hold.

1. Examine the monitor display for tearing or any other sign of horizontal instability.
2. If needed, adjust the horizontal hold (HH) control (Figure 4-6) to stop any horizontal movement.

4.3.4 Focus

Use the following procedure to adjust the focus control.

1. Examine the pattern at the four corners and in the center of the screen. Each line should be sharp and well-defined.
2. If the lines are not sharp and well-defined, adjust the focus control (FOC) for the sharpest overall display (see Figure 4-7).

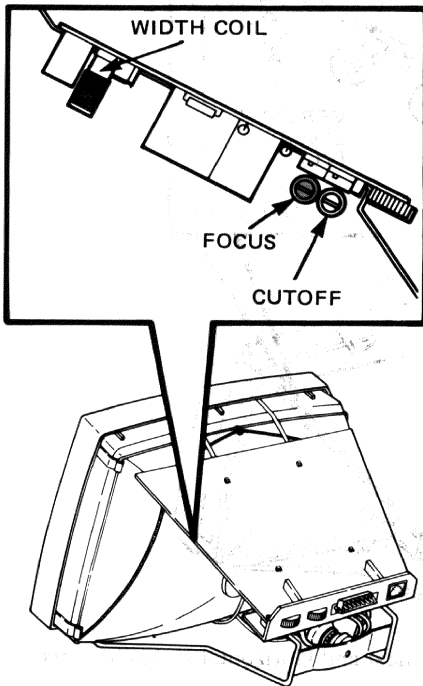

Figure 4-7 Focus Control

4.3.5 Vertical Centering and Rotation Check without Color/Graphics Option

Use the following procedure to check the vertical centering and rotation.

NOTE

If you have a color/graphics option, this adjustment is more critical, and you must use a video alignment template (29-24371). See Paragraph 4.3.6.

1. The screen of E's should be about 4 mm (5/32 in) below center. If the screen of E's is too high or too low, replace the entire monitor. Vertical centering is not adjustable.
2. If the screen of E's slants across the screen or curves or bows by more than 3 mm (1/8 in) at the top or bottom of the screen, replace the entire monitor. Rotation (slanting) and pincushion (bowing) are not adjustable.

NOTE

The electrical center of the screen is not the same as the apparent physical center of the screen. When the monitor is adjusted correctly, the screen display will be offset towards the bottom of the screen.



4.3.6 Vertical Centering and Rotation Check for Color/Graphics Option

Use the following procedure to check the vertical centering and rotation.

NOTE

A video alignment template (29-24371) is required for the following checks.

1. Measure the distance in three places between the bottom edge of the alignment pattern and the monitor bezel (Figure 4-8). Use the scale on the template for the measurements. Make a note of each measurement.
2. Compare all three measurements. The difference between the measurements should not be greater than ± 2 mm (1/16 in). If the difference is greater, go to step 5.
3. Measure the distance between the top center edge of the alignment pattern and the monitor bezel. Use the scale on the template for the measurement.
4. Compare the measurements from steps 1 and 3. The top measurement should be larger by at least 1 mm (1/32 in) but no more than 7 mm (9/32 in). If the difference is greater, go to step 5.
5. If any of the measurements are out of tolerance, replace the monitor assembly.

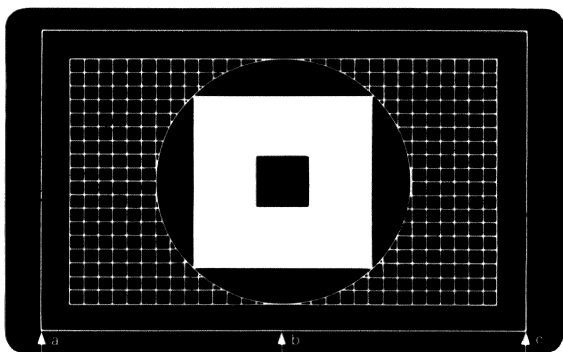

$$a = b = c (\pm 2 \text{ mm})$$

Figure 4-8 Vertical Centering and Rotation Check with Alignment Template

4.3.7 Horizontal Centering and Width Coil

These two adjustments can affect each other and may also affect the horizontal hold adjustment. Therefore, after adjusting either the horizontal centering control or the width coil, you may have to readjust the others slightly.

NOTE

If you have a color/graphics option, these adjustments are more critical, and you must use a video alignment template. See Paragraphs 4.3.10 and 4.3.11.

1. Adjust the horizontal centering (PH) control (Figure 4-9) so that the screen of E's is centered side to side.

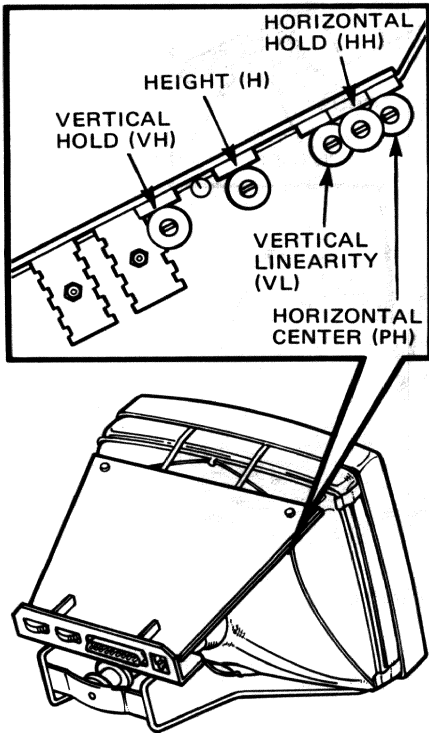

Figure 4-9 Monitor Module Controls – Left Side

2. Adjust the width coil (Figure 4-10) for comfortable viewing.
3. Recheck the horizontal hold adjustment (Paragraph 4.3.3).

NOTE

You cannot adjust vertical centering and rotation.

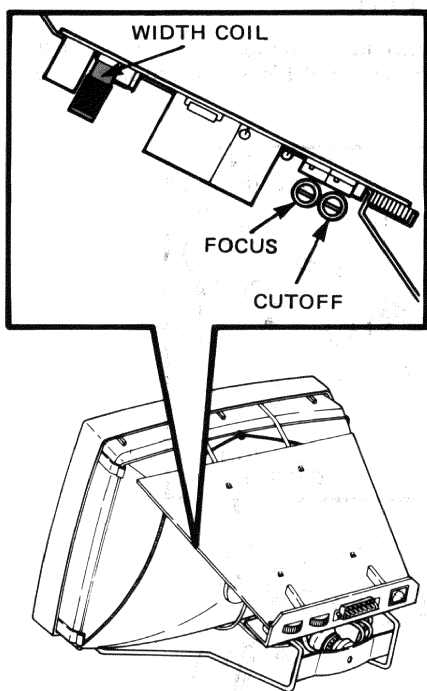

Figure 4-10 Width Coil

4.3.8 Cutoff

The cutoff control (Figure 4-10) sets the monitor's sensitivity to the video signal from the system module. It sets the video signal voltage needed to blank out a spot on the screen. If you replace the monitor board, perform the following steps.

1. Place the old and the new monitor boards side-by-side with the cutoff controls (CO) at the same end.
2. Set the cutoff control on the new monitor board to match the setting on the old board.
3. Check the video monitor adjustments.

4.3.9 Height and Vertical Linearity

The height and vertical linearity controls can affect each other and may affect the vertical hold adjustment. After adjusting either the height or the vertical linearity controls, you may have to readjust the vertical hold slightly.

NOTE

If you have a color/graphics option, these adjustments are more critical, and you must use a video alignment template. See Paragraphs 4.3.10 and 4.3.11.

1. Adjust the vertical linearity (VL) control (Figure 4-9) until there is no distortion in the screen of E's (the E's on the top of the screen are the same height as the E's on the bottom and at the center of the screen).
2. Adjust the height (H) control (Figure 4-9) for comfortable viewing.

4.3.10 Horizontal Centering for Color/Graphics Option

Use the following procedure to check the horizontal centering.

NOTE

A video alignment template is required for this adjustment.

1. Measure the distance between the center left edge of the alignment pattern and the monitor bezel (Figure 4-11). Use the scale on the template for the measurement. Make a note of the measurement.
2. Measure the distance between the center right edge of the alignment pattern and the monitor bezel. Use the scale of the template for the measurement. Make a note of the measurement.
3. Compare the measurements from steps 1 and 2. If the difference between the two measurements is greater than 6 mm (1/4 in), adjust the horizontal center (PH) control (Figure 4-9).
4. Repeat steps 1 and 2 to verify that the adjustment is less than 6 mm (1/4 in).

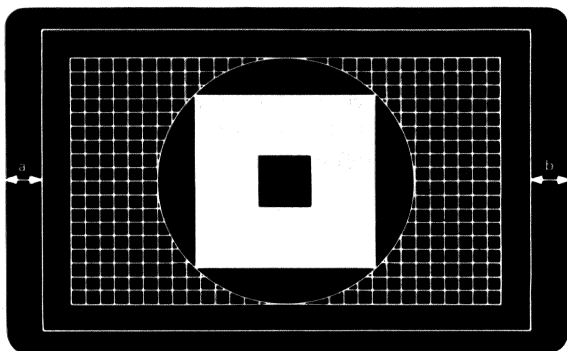

$$b - a < 6 \text{ mm}$$

Figure 4-11 Horizontal Centering

4.3.11 Aspect Ratio (Horizontal Width and Height) for Color/Graphics Option

Use the following procedure to adjust the aspect ratio.

NOTE

A video alignment template is required for this adjustment.

1. Using the alignment template, measure the height of the center square (Figure 4-12). It should be 25 mm (1 in) \pm 2 mm (1/16 in). If not, adjust the height (H) control (Figure 4-9).
2. Measure the width of the center square. This side should be within 1 mm (1/32 in) of the height. If not, adjust the width coil (Figure 4-10).
3. Recheck the horizontal centering (Paragraph 4.3.10); then, check the vertical linearity (Paragraph 4.3.12).

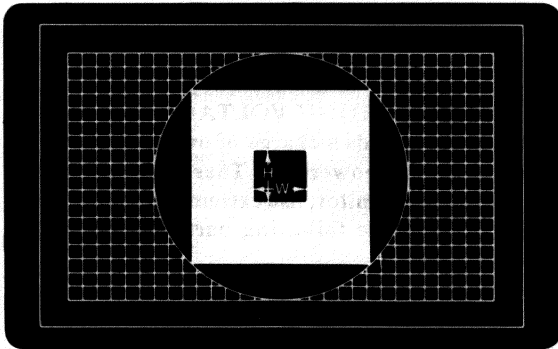

$$H = 25 \text{ mm } (\pm 2 \text{ mm})$$

$$W = H (\pm 1 \text{ mm})$$

Figure 4-12 Aspect Ratio

4.3.12 Vertical Linearity for Color/Graphics Option

Use the following procedure to adjust the vertical linearity.

NOTE

A video alignment template is required for this adjustment.

1. Check the height of the crosshatch pattern near the four corners of the display. The pattern should have the same height in all four corners.
2. If not, adjust the vertical linearity (VL) control (Figure 4-9) until the pattern is the same height in all four corners.
3. Check the aspect ratio (Paragraph 4.3.11).

4.4 Reassemble the Video Monitor

Use the following procedure to reassemble the video monitor.

1. Set the power switch on the system unit to 0 (off).

WARNING**SOURCES OF HIGH VOLTAGE**

The monitor holds a charge of over 12,000 V even with the power off. Therefore, when adjusting the monitor, use extreme care, especially around the following parts, shown in Figure 4-13.

- Anode and anode wire
 - Flyback transformer
 - Connector at neck of CRT
2. Unplug all of the cables from the back of the video monitor.
 3. Discharge the anode connection of the CRT. (See Paragraph 4.2, step 8.)
 4. Place some protective material over the screen to protect it from scratches.
 5. Place the monitor face down on a flat surface.
 6. Keep the tilt foot extended. If the tilt foot is not fully extended, it will catch on the internal wires of the monitor when you replace the cover.

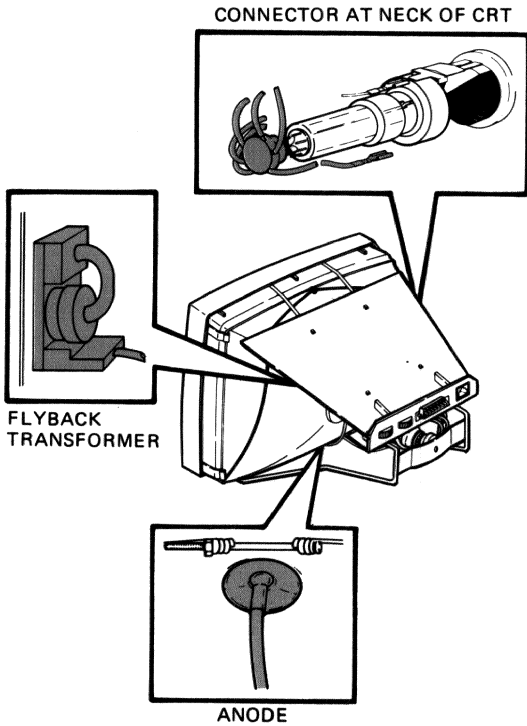
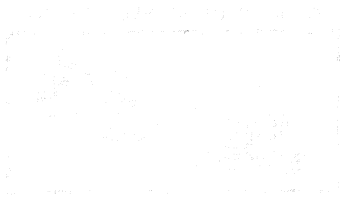

Figure 4-13 Sources of High Voltage

7. Slide the monitor cover on and make sure it is seated correctly.
8. Install the screw in the monitor cover to hold it in place.
9. Replace the screw cap into the back of the monitor.
10. Return the monitor to its normal operating position.
11. Remove the protective material from the screen.
12. Reconnect all the cables to the video monitor.
13. If needed, clean the screen with the recommended screen cleaner (49-01607-01) or isopropyl alcohol.
14. Set the power switch on the system unit to 1 (on).



THE STATE OF CALIFORNIA,
COUNTY OF _____
I, _____, County Clerk,
do hereby certify that _____
is the true and correct copy
of the _____
of _____
as the same appears from the
records on file in my office.

IN WITNESS WHEREOF, I have hereunto set my hand and the seal of said County, this _____ day of _____, 19____.

County Clerk



5 REMOVAL AND REPLACEMENT PROCEDURES

5.1 INTRODUCTION

The maintenance philosophy for the Rainbow computer is replacement of the field replaceable unit (FRU). This chapter describes the removal and replacement procedures for the following field replaceable units.

- Floor stand
- System module
- RX50 controller board
- RX50 diskette drive
- Memory board option
- Color/graphics option
- Extended communications option
- Hard disk controller board
- RD51 hard disk drive option
- Keyboard
- Fan bracket assembly
- Fan
- Power switch
- Power supply
- Monitor
- Monitor module (black and white monitor only)

Figure 5-1 shows the order in which you must remove the units. To install the same FRU, perform the removal steps in reverse order unless otherwise noted.

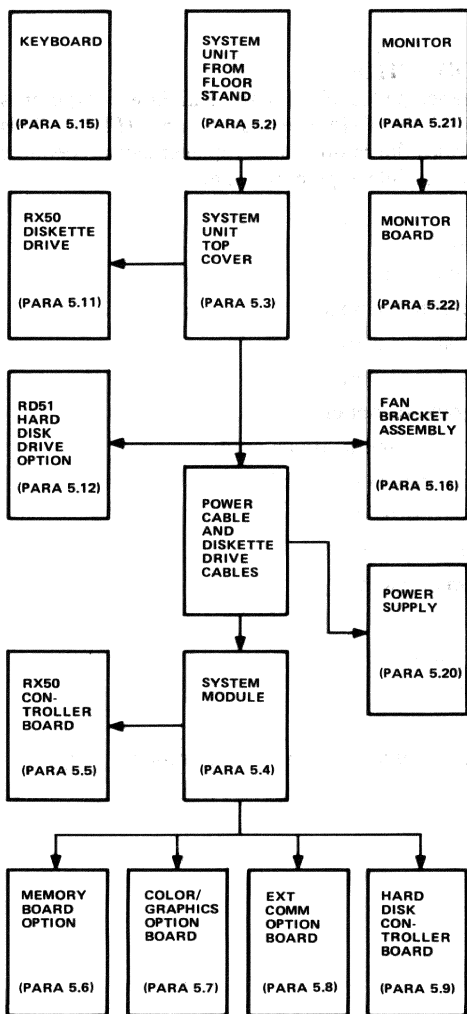

Figure 5-1 FRU Removal Sequence

5.2 REMOVE SYSTEM UNIT FROM FLOOR STAND

Perform the following steps to remove the system unit from the floor stand if present.

1. Set the power switch to 0 (off) and unplug the power cord.
2. Open the rear door of the floor stand and remove all the cables from the system unit.
3. Close the rear door of the floor stand, and place the floor stand on a desk so its door opens downward (Figure 5-2).

CAUTION

The system unit and floor stand together weigh 21.8 kg (48 lb). Two people should lift the unit.

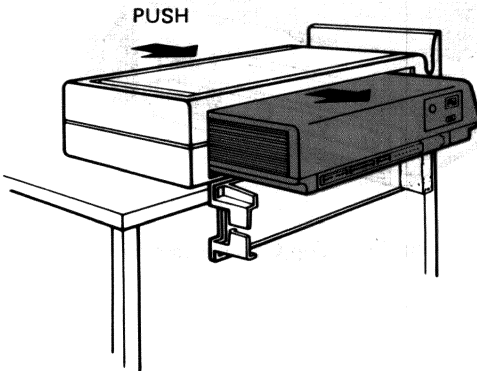

Figure 5-2 Removing System Unit from Floor Stand

4. Open the rear door of the floor stand. Lift and slide the system unit out of the stand and place it on a desk.

5.3 TOP COVER REMOVAL

Perform the following steps to remove the top cover of the system unit.

1. Remove any diskettes from the drives.
2. Close the drive doors.
3. Set the power switch to 0 (off) and remove the power cord.
4. Slide the two cover release tabs away from you and out.
5. Lift cover as shown in Figure 5-3.

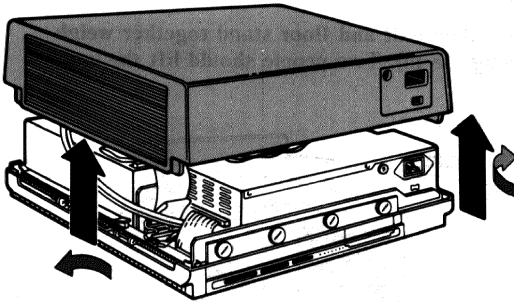

Figure 5-3 System Unit Top Cover Removal

5.4 SYSTEM MODULE REMOVAL AND INSTALLATION

Perform the following steps to remove the system module.

1. Remove the power cord from the wall and from the system unit.
2. Remove all cables from the back of the system unit, especially if you have a color monitor.
3. Remove the system unit from the floor stand if present (Paragraph 5.2).
4. Remove the system unit top cover. See Figure 5-3.
5. Unplug the power cable from the power supply (Figure 5-4).

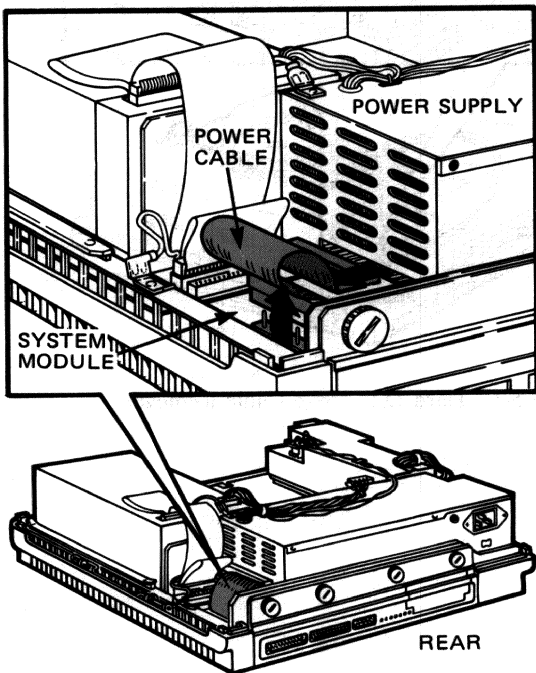

Figure 5-4 Power Cable Removal

6. Unplug the hard disk drive cable if it is present (Figure 5-5). Leave the ground clip attached.

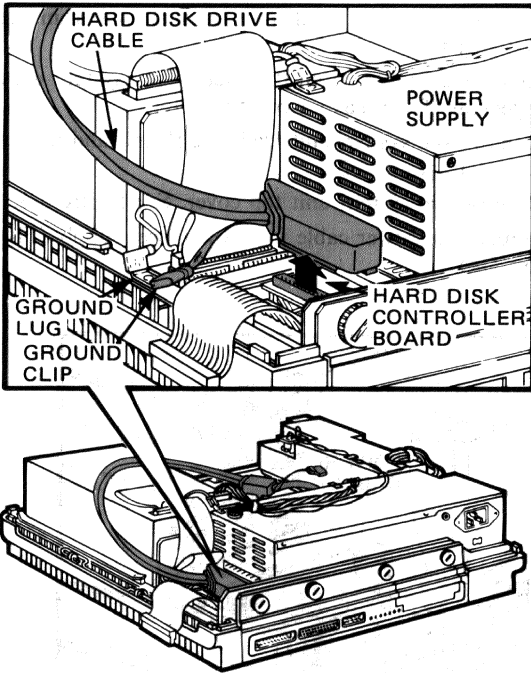

Figure 5-5 Hard Disk Drive Cable Removal

7. Unplug the power cable from the system module (Figure 5-4).
8. Unplug the diskette drive flat cable(s) as shown in Figure 5-6. Leave the ground clip(s) attached.

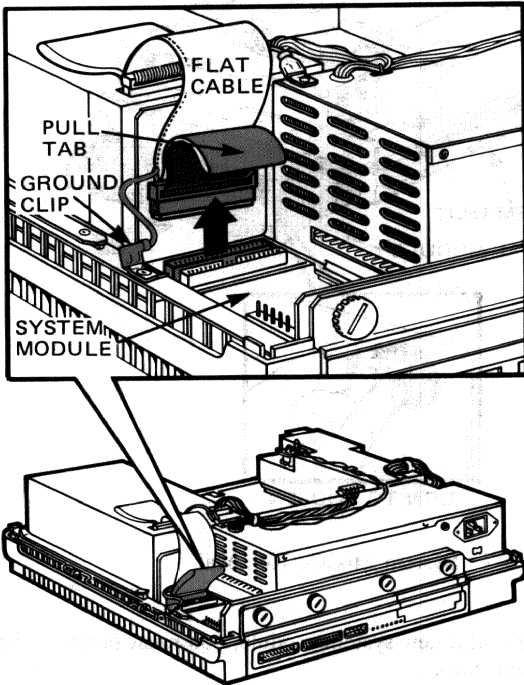

Figure 5-6 Diskette Drive Flat Cable Removal

9. Use a coin and turn all four screws once (Figure 5-7). Repeat until all four screws are loose and you can slide the system module out of the system unit.

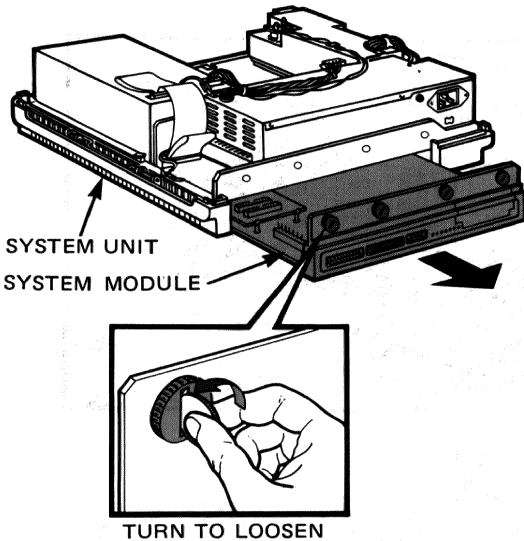

Figure 5-7 System Module Removal

To install a new system module, you must perform the following steps.

1. Remove all controller and option boards from the old system module. See Paragraphs 5.5 through 5.9.
2. Remove the language ROM if you have a keyboard other than English for the PC100A (Paragraph 5.10.2) and other than English, French, or German for the PC100B (Paragraph 5.10.3)
3. If applicable, remove the language ROM from the new system module and install the ROM you removed in step 2 above.
4. Install all controller and option boards on the new system module. See Paragraphs 5.5 to 5.9.
5. Slide the new system module into the system unit.
6. Use a coin to turn all four screws once. Repeat until each screw is tight.

7. Connect the diskette drive flat cable(s).
8. Plug the power cable into the connector on the system module.
9. If present, plug the hard disk drive cable into the hard disk controller board (Figure 5-8).
10. Plug the power cable firmly into the power supply.
11. Replace the top cover on the system unit.
12. Connect all cables and the power cord to the system unit.
13. Plug in the power cord and set the power switch to 1 (on).
14. With the customer's help, check the Set-Up features (see Chapter 2). Because the Set-Up features are stored in nonvolatile memory (NVM) on the system module, replacing this module will change the Set-Up features.

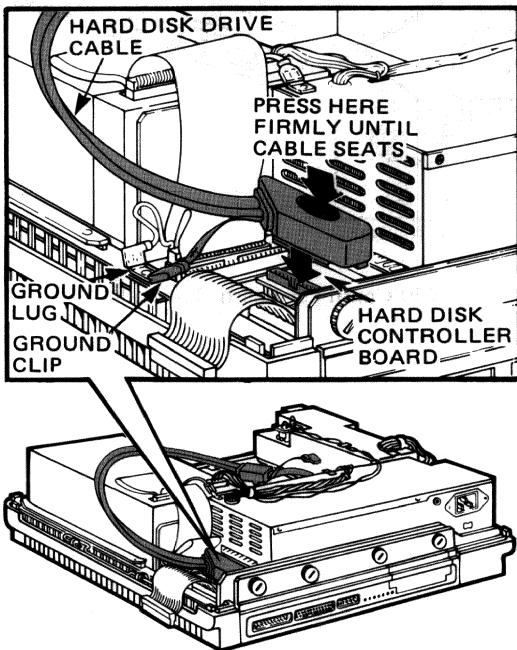

Figure 5-8 Installing Hard Disk Cable

5.5 RX50 CONTROLLER MODULE REMOVAL

Perform the following steps to remove the RX50 controller module.

WARNING

For your safety, disconnect the power cord.

1. Remove the system module (Paragraph 5.4).
2. Push the top of the connector clip and each standoff aside and lift the RX50 controller module off of the system module as shown in Figure 5-9.

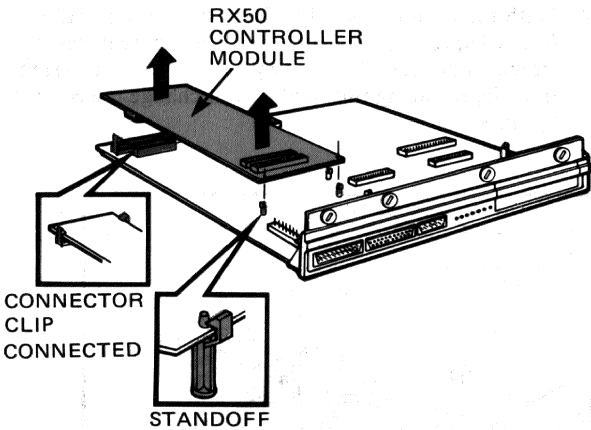

Figure 5-9 RX50 Controller Board Removal

5.6 MEMORY BOARD REMOVAL

Perform the following steps to remove the memory board.

WARNING

For your safety, disconnect the power cord.

1. Remove the system module (Paragraph 5.4).
2. Push the top of the three standoffs aside and lift the memory board off of the system module. See Figure 5-10.

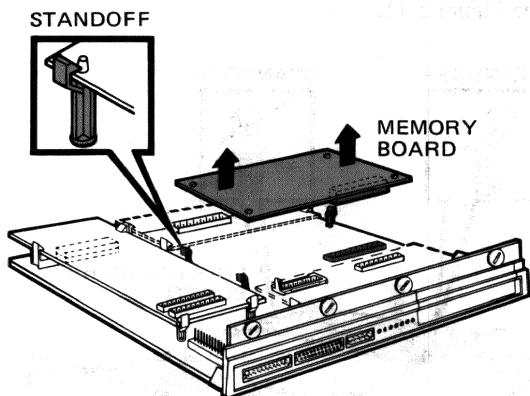

Figure 5-10 Memory Board Removal

5.7 COLOR/GRAPHICS OPTION BOARD REMOVAL

Perform the following steps to remove the color/graphics option board.

WARNING

For your safety, disconnect the power cord.

1. Remove the system module (Paragraph 5.4).
2. Push the top of each standoff aside and lift the color/graphics option board off of the system module. See Figure 5-11.

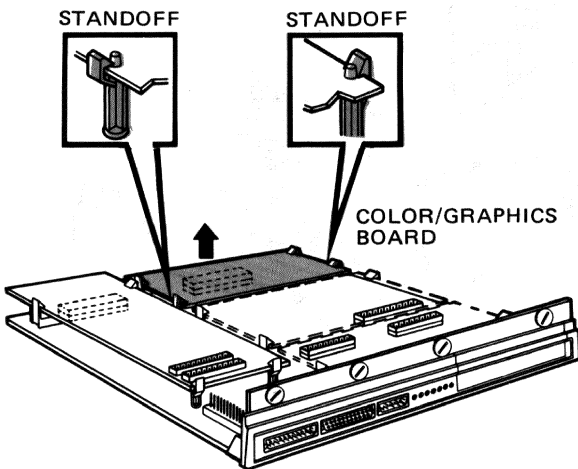

Figure 5-11 Color/Graphics Option Board Removal

5.8 EXTENDED COMMUNICATIONS OPTION BOARD REMOVAL

Perform the following steps to remove the extended communications option board.

WARNING

For your safety, disconnect the power cord.

1. Remove the system module (Paragraph 5.4).
2. Push each standoff aside and lift the extended communications option board off of the system module. See Figure 5-12.

NOTE

When replacing the extended communications option board, tip the board at an angle to get its metal connectors through the holes in the back panel of the system unit.

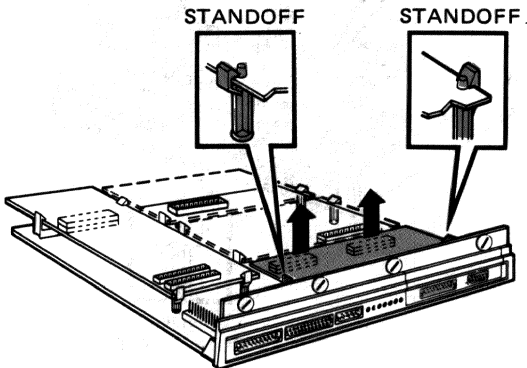

Figure 5-12 Extended Communications Option Board Removal

5.9 HARD DISK CONTROLLER BOARD REMOVAL

Perform the following steps to remove the hard disk controller board.

WARNING

For your safety, disconnect the power cord.

1. Remove the system module (Paragraph 5.4).
2. Push the top of the connector clip and the two standoffs aside and lift the hard disk controller board off of the system module. See Figure 5-13.
3. When replacing the hard disk controller board, remove the spacer and install it on the new board. If the new board has a spacer in the package, install the new spacer on the board.

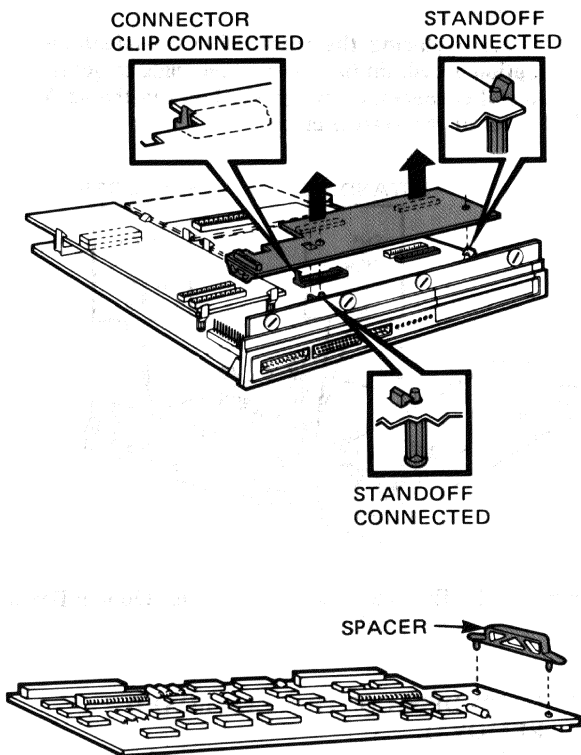

Figure 5-13 Hard Disk Controller Board Removal

5.10 ROM REMOVAL

The PC100A has three ROMs that can be replaced; the PC100B has two ROMs that can be replaced. They contain firmware for the power-up diagnostic, Main System Menu, keyboard language, selftest diagnostic, Set-Up features, and terminal mode features.

5.10.1 PC100A ROMs 0 and 1 Removal and Replacement

You should always replace ROMs 0 and 1 as a pair in the PC100A to ensure that the firmware programming in each has the same version number. Perform the following steps to replace these ROMs.

CAUTION

If your system module has a QIKEJECT™ chip socket, as shown in Figure 5-14, it will break if you pry the chip up out of the socket. Use a screwdriver to push the chip sideways instead.

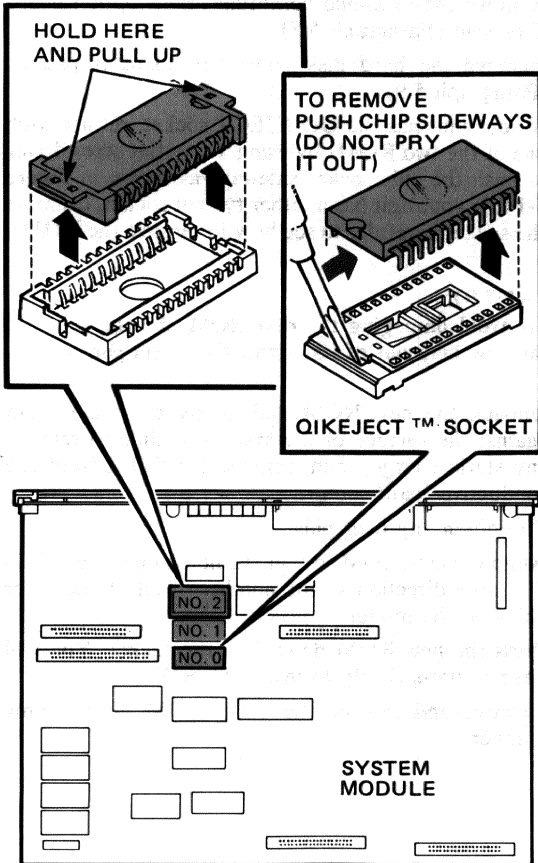

Figure 5-14 ROM Removal on PC100A

WARNING

For your safety, disconnect the power cord.

1. Remove the system module (Paragraph 5.4).
2. Remove the memory board if present (Paragraph 5.6).
3. Remove the extended communications option board if present (Paragraph 5.8).
4. Remove the hard disk controller board if present (Paragraph 5.9).
5. If your unit has the QIKEJECT socket, release each one of the two ROMs by using a tiny flat screwdriver to push the chip socket sideways as shown in Figure 5-14. If your unit has another type of socket, examine the socket carefully to see how to remove the ROMs.

CAUTION

To avoid damaging the new ROM, do not pull the new chip out of its conductive foam pad.

6. Unpack the new ROM and gently press the foam against the surface of the system module to remove any static charge; then, remove the ROM from the conductive foam.
7. Straighten any bent pins.
8. Align the new ROM so that the notch on one end is in the same direction as the notches of all of the other chips on the module.
9. Press the new ROM down into the socket. You will have to press firmly to insert the ROM.
10. Remove and replace the other ROM in the same manner.

5.10.2 PC100A ROM 2 (Language ROM) Removal and Replacement

Perform the following steps to replace the language ROM in the PC100A.

WARNING

For your safety, disconnect the power cord.

1. Remove the system module (Paragraph 5.4).
2. To remove the old ROM, pull it up as shown in Figure 5-14. You will have to pull hard.
3. The new language ROM comes with an antistatic cover. Do not remove this cover. It will pop off automatically when you insert the ROM into the ROM socket.
4. To insert the new ROM, orient it so that it matches the keys on the ROM socket.
5. Press the ROM down into the socket.

5.10.3 PC100B ROMs 0 and 1 Removal and Replacement

ROMs 0 and 1 on the PC100B can be replaced separately. ROM 0 has the firmware; ROM 1 has 3 languages and may need to be replaced in specific countries to match the keyboard of that country. The ROM languages and part numbers are listed in Appendix A.

Perform the following steps to replace these ROMs.

WARNING

For your safety, disconnect the power cord.

1. Remove the system module (Paragraph 5.4).
2. Remove the memory board if present (Paragraph 5.6).
3. Remove the extended communications option board if present (Paragraph 5.8).
4. Remove the hard disk controller board if present (Paragraph 5.9).

5. Use a small flat screwdriver to gently lift each end of the ROM, shown in Figure 5-15, until you can lift it out of its socket.

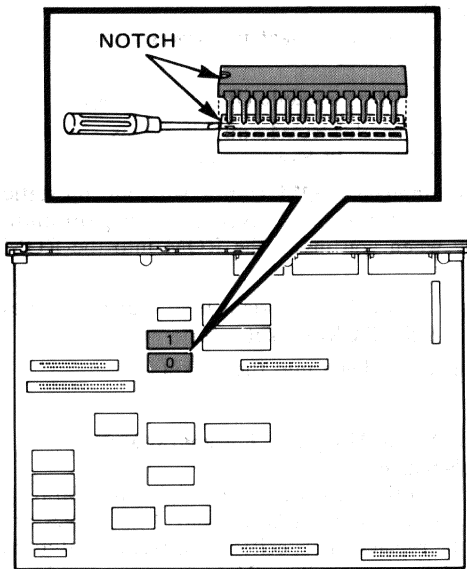

Figure 5-15 ROM Removal on PC100B

6. Unpack the new ROM but **DO NOT** remove it from its conductive foam.
7. Gently press the foam against the surface of the system module to remove any static charge; then, remove the ROM from the conductive foam.
8. Straighten any bent pins.
9. Align the new ROM so that the notch on one end is in the same direction as the notches of all of the other chips on the module.
10. Alternately, press each top half of the ROM until it seats firmly in its socket.

5.11 RX50 DISKETTE DRIVE REMOVAL

Perform the following steps to remove the RX50 diskette drive.

1. Prepare the diskette drive for shipment, if applicable.
 - a. Turn the power on.
 - b. After the power-up test is finished, turn the power off. This ensures that the head is at track zero so that the protective card will fit properly and not damage the read/write head.
 - c. Insert the protective card into the upper drive(s) and close all diskette drive doors. See Figure 5-16.

WARNING

For your safety, disconnect the power cord.

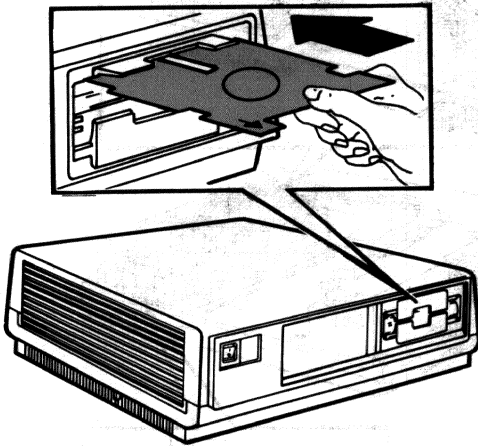

Figure 5-16 Inserting Protective Card

92 REMOVAL AND REPLACEMENT PROCEDURES

2. Remove the system unit top cover (Paragraph 5.3).
3. Unplug the diskette drive flat cable from the top of the diskette drive (Figure 5-17).
4. Unplug the 4-wire power cable from the top of the diskette drive (Figure 5-17).
5. Press the latch with a pencil and slide the diskette drive out as shown in Figure 5-17.
6. Slide the new diskette drive into the system unit.
7. Connect the cables removed in steps 3 and 4 above.
8. Remove the protective card.
9. Apply A and B or C and D labels to the front of the new diskette drive.

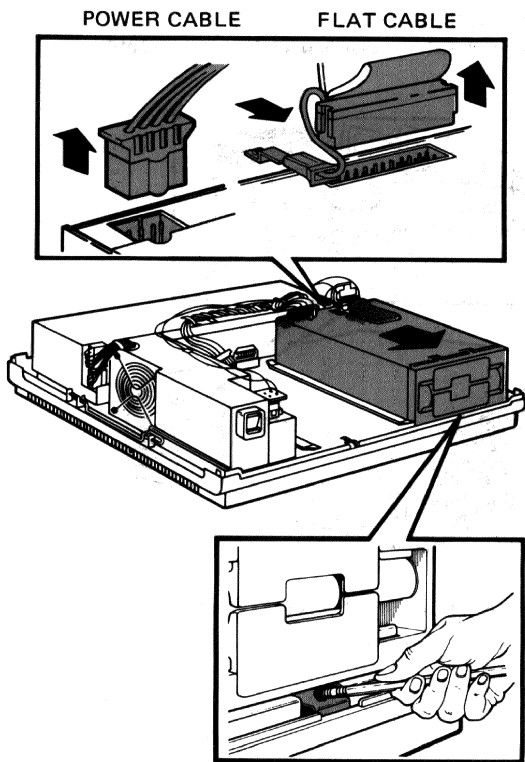

Figure 5-17 Diskette Drive Flat Cable and 4-Wire Power Cable Removal

5.12 RD51 HARD DISK DRIVE (WINCHESTER) REMOVAL

Perform the following steps to remove the hard disk drive.

1. Remove the system unit top cover (Paragraph 5.3).

WARNING

For your safety, disconnect the power cord.

2. Unplug the ground clip of the hard disk drive cable from the power supply (Figure 5-18).
3. Press the latch with a pencil and slide the hard disk drive forward (Figure 5-18).

CAUTION

DO NOT drop or bump the hard disk drive. It is a delicate precision instrument and subject to damage if handled roughly.

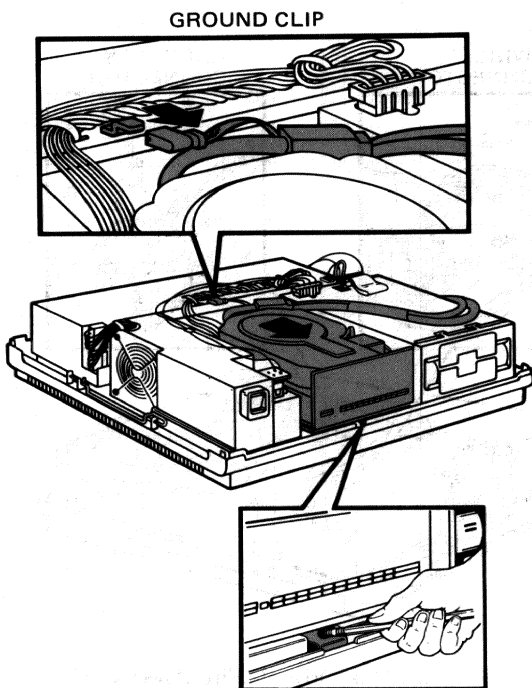

Figure 5-18 Ground Clip and Hard Disk Drive Removal

4. Unplug the 4-wire power cable from the back of the hard disk drive. (Figure 5-19)
5. Pull the hard disk drive cable straight out of the back of the hard disk drive (Figure 5-19). Do not remove this cable at an angle to the disk drive.

NOTE

Replace the hard disk drive cable with another to check if the cable is causing the problem before replacing the disk drive. A bent pin in one of its connectors is difficult to see and almost impossible to fix. (See Paragraph 5-13.)

6. Slide the hard disk drive out of the system unit and place it in its original packing material if it is to be transported.

CAUTION

DO NOT drop or bump the hard disk drive.

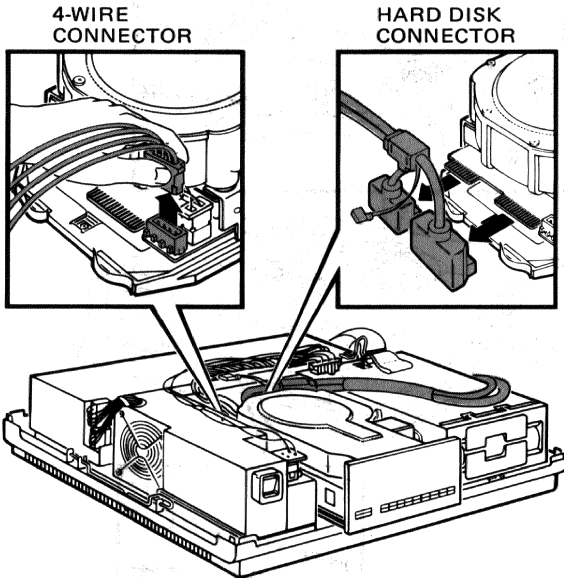

Figure 5-19 Hard Disk Drive 4-Wire Power Cable and Hard Disk Drive Cable Removal

5.13 HARD DISK DRIVE CABLE REMOVAL AND INSTALLATION

Perform the following steps to remove the hard disk drive cable from the controller board.

WARNING

For your safety, disconnect the power cord.

1. Remove the system unit top cover (Paragraph 5.3).
2. Remove the hard disk drive (Paragraph 5.12).
3. Unplug the power cable from the power supply (Figure 5-20).

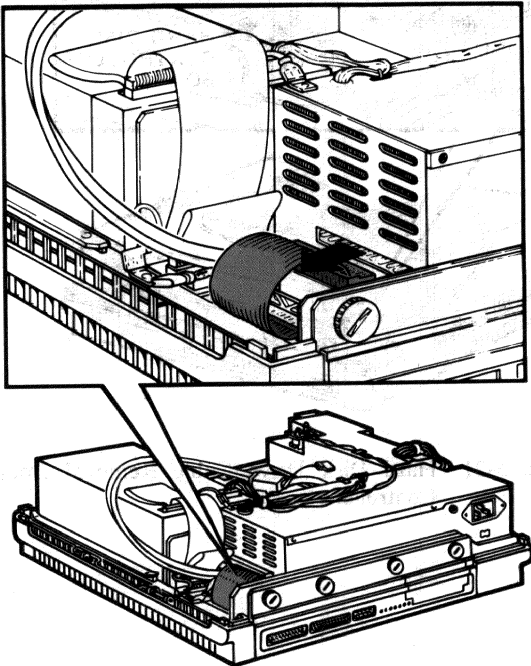

Figure 5-20 Power Cable Removal

4. Unplug the hard disk drive cable from the hard disk controller board (Figure 5-21). Unplug its ground clip.

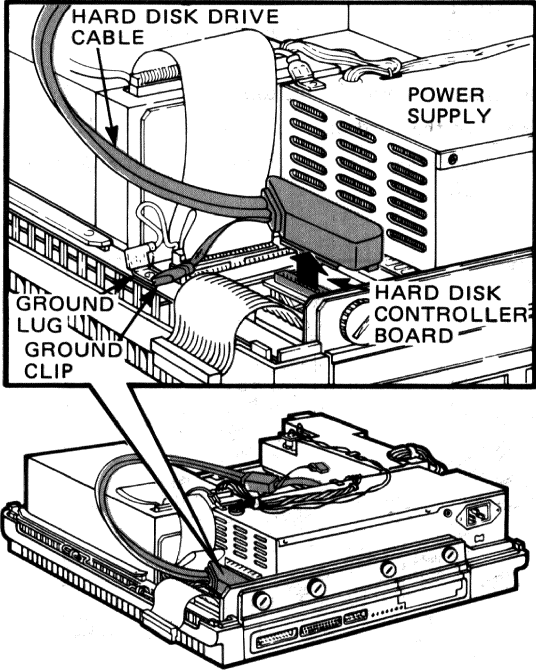

Figure 5-21 Hard Disk Drive Cable Removal from Controller

To install a new hard disk drive cable, perform the following steps.

1. Press the hard disk drive cable connector firmly as shown in Figure 5-22, until the connector seats fully and is level.
2. Connect the ground clip to the ground lug.
3. Plug the power cable (removed in step 3 above) into the power supply.
4. Install the hard disk drive (Paragraph 5.14).

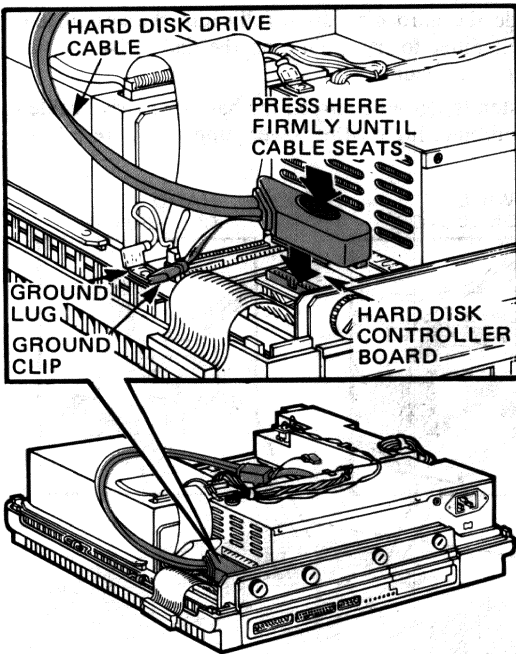

Figure 5-22 Connecting Hard Disk Drive Cable Firmly

5.14 HARD DISK DRIVE INSTALLATION

1. Unpack the new hard disk drive and slide it partially into the system unit.
2. Connect the hard disk drive cable connectors (Figure 5-23) installing them straight onto the hard disk drive. Do not install them at an angle to the hard disk drive.
3. Make sure the hard disk drive cable lies flat across the diskette drive (Figure 5-24).
4. Plug the 4-wire power cable into the power connector on the disk drive (Figure 5-23).
5. Slide the hard disk drive fully into the system unit. Remember to try pulling on the disk drive to make sure it is secure.
6. Fasten the ground clip on the hard disk drive cable to the ground lug on the power supply (Figure 5-24).

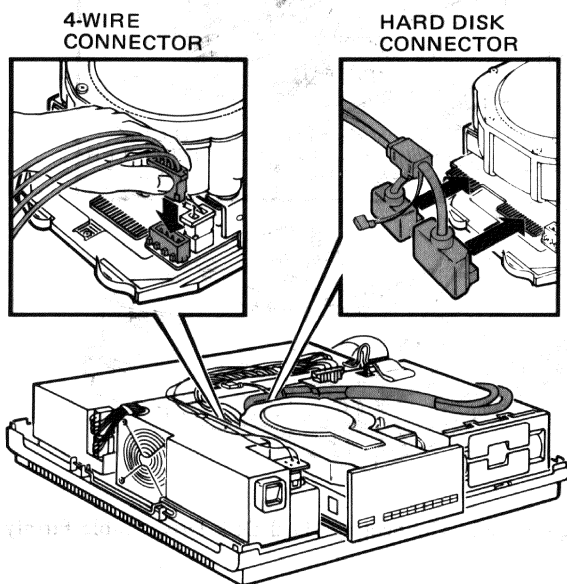

Figure 5-23 Hard Disk Drive Cable and 4-Wire Power Cable Installation (to disk drive)

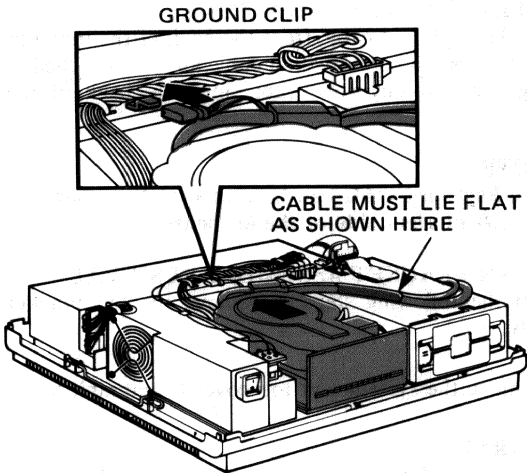

Figure 5-24 Fastening Ground Clip to Power Supply

CAUTION

Do not transport the hard disk drive without its shipping box.

Pack the hard disk drive in its original packing material to prevent damage from shock and vibrations.

5.15 KEYBOARD REPLACEMENT

Unplug the keyboard cable from the back of the monitor. The new keyboard comes with a cable already attached to it. Plug the new keyboard cable into the back of the monitor.

NOTE

The keyboard cable can be routed to fit either the left or right side of the keyboard.

5.16 FAN BRACKET ASSEMBLY REMOVAL

Perform the following steps to remove the fan bracket assembly.

1. Remove the system unit top cover (Paragraph 5.3).

WARNING

For your safety, disconnect the power cord.

2. Remove the fan assembly plugs from your power supply by pinching the sides and pulling hard (Figure 5-25).

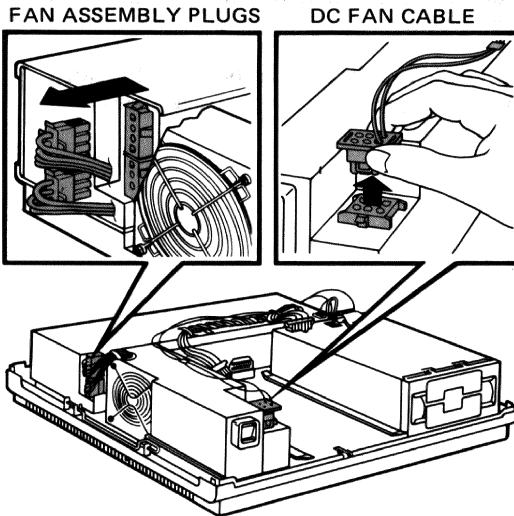

Figure 5-25 Unplugging Fan Assembly Plugs and DC Fan Cable

3. Unplug the dc fan cable from the front of the fan assembly (PC100B only). See Figure 5-25.
4. Remove the three screws on the top of the fan bracket assembly as shown in Figure 5-26.
5. Lift the fan bracket assembly up (Figure 5-26).

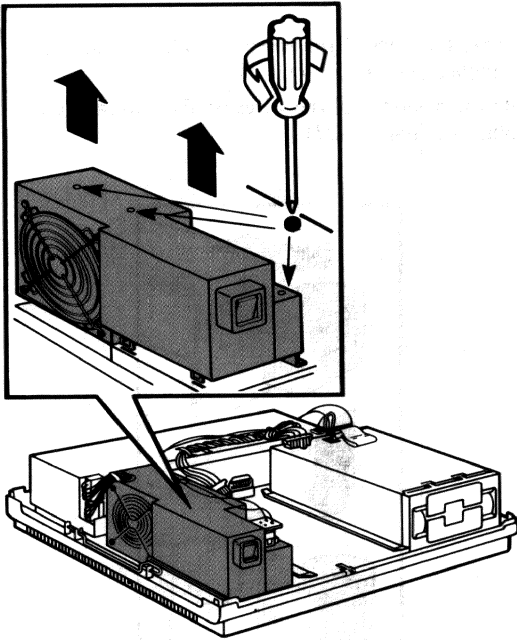

Figure 5-26 Fan Bracket Assembly Removal

5.17 POWER SWITCH (1/0) REMOVAL

Perform the following steps to remove the power switch.

1. Remove the system unit top cover (Paragraph 5.3).

WARNING

For your safety, disconnect the power cord.

2. Squeeze the sides of the power switch and pull it out a few inches (Figure 5-27).
3. Note the positions of the wires on the switch and then unplug it (Figure 5-27).

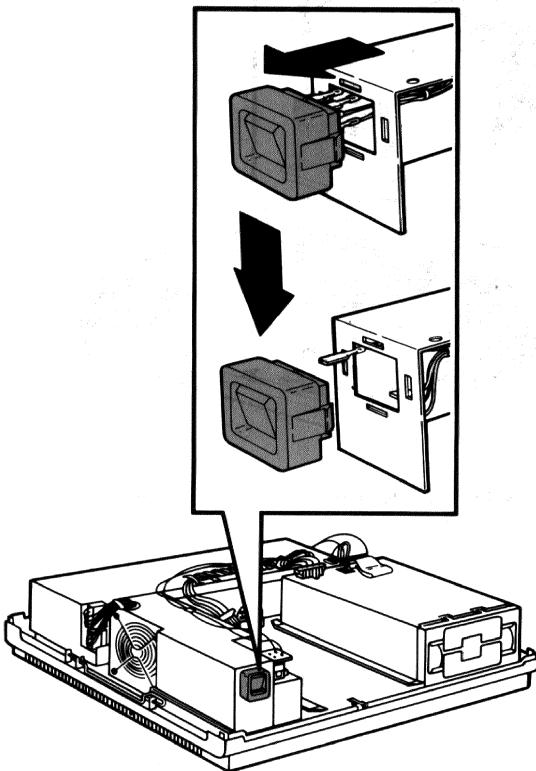

Figure 5-27 Removing Power Switch

5.18 FAN REMOVAL (PC100A)

To remove the fan from the fan bracket assembly, perform the following steps.

1. Remove the system unit top cover (Paragraph 5.3).

WARNING

For your safety, disconnect the power cord.

2. Remove the fan bracket assembly (Paragraph 5.16).
3. Remove the power switch and unplug the two wires on the fan (Figure 5-28).
4. Remove the four screws that hold the fan in place (Figure 5-28).

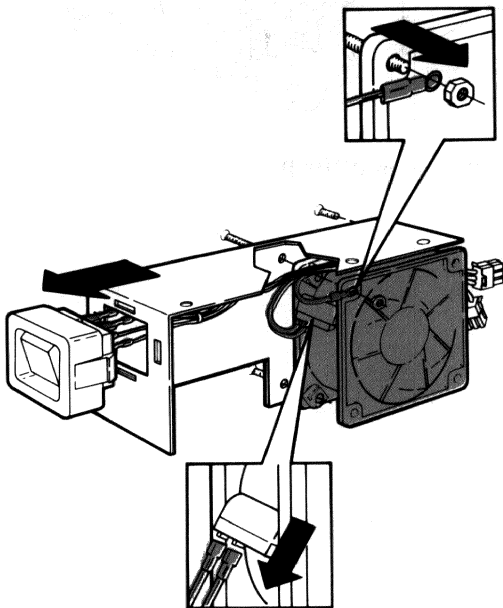

Figure 5-28 Fan in PC100A

5.19 FAN REMOVAL (PC100B)

In the PC100B, do not replace the fan (Figure 5-29) in the field; rather, replace the entire fan bracket assembly. See Paragraph 5.16.

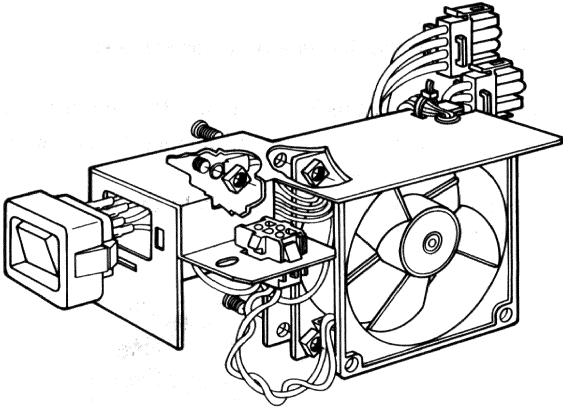

Figure 5-29 Fan in PC100B

5.20 POWER SUPPLY REMOVAL

Perform the following steps to remove the power supply.

1. Remove the system unit top cover (Paragraph 5.3).

WARNING

For your safety, disconnect the power cord.

2. Unplug the 4-wire power connector from the diskette drive(s), as shown in Figure 5-30.
3. Unplug the ground clip from the ground lug on top of the power supply, Figure 5-30.

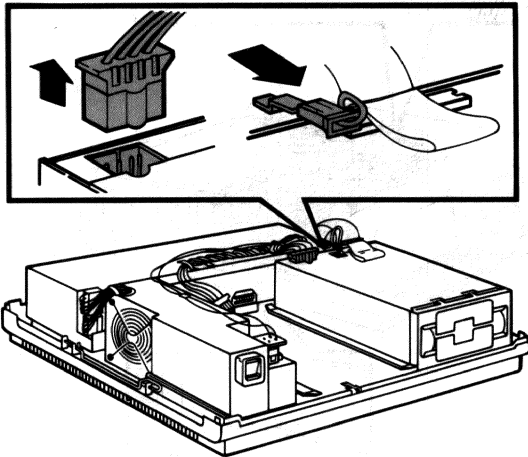

Figure 5-30 Unplugging 4-Wire Cable and Ground Clip

4. If a hard disk drive (Winchester) is present, unplug the ground clip from the power supply (Figure 5-31). Press the front latch with a pencil and slide the hard disk drive forward (Figure 5-31). Unplug the 4-wire power cable from the hard disk drive (see Figure 5-32).

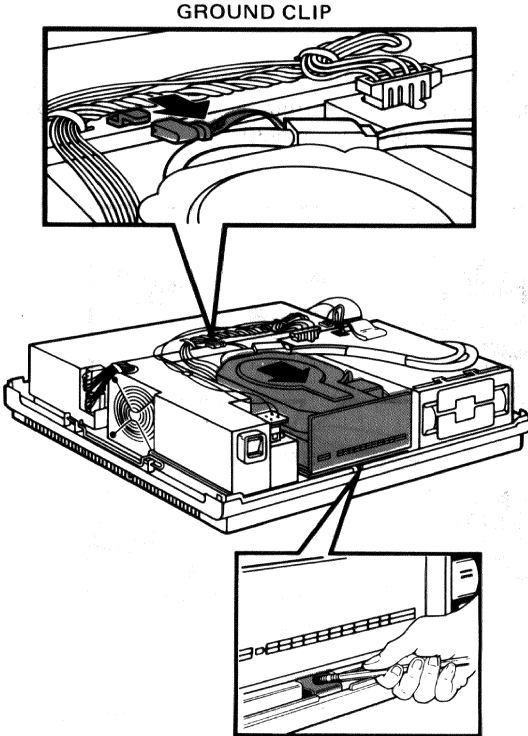

Figure 5-31 Unplugging Ground Clip and Sliding Hard Disk Drive Forward

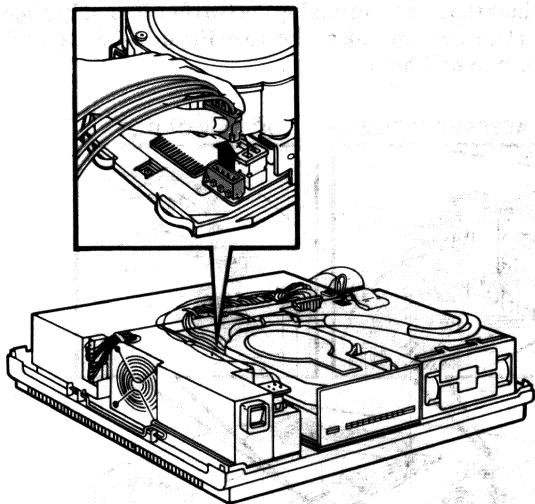

Figure 5-32 Unplugging 4-Wire Cable

5. (PC100B only) Unplug the dc fan cable from the connector in front of the fan assembly. (See Figure 5-33.) Disconnect this cable from any tie-down clip on top of the fan bracket assembly.

- 6. Pinch the sides and unplug the two fan assembly plugs that are near the fan, as shown in Figure 5-33. You will have to pull hard.

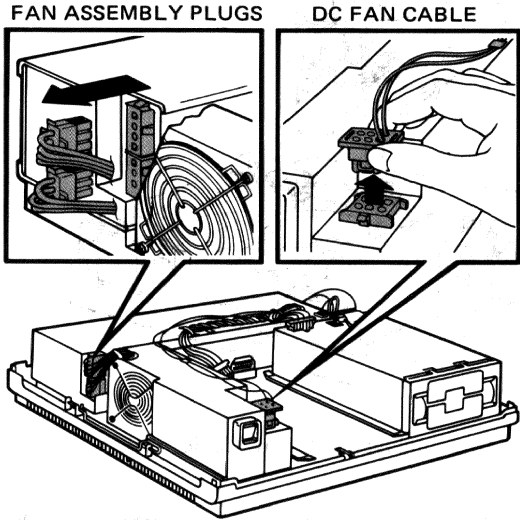

Figure 5-33 Unplugging DC Fan Cable and Plugs Near Fan

7. Unplug the power cable from the power supply (Figure 5-34).

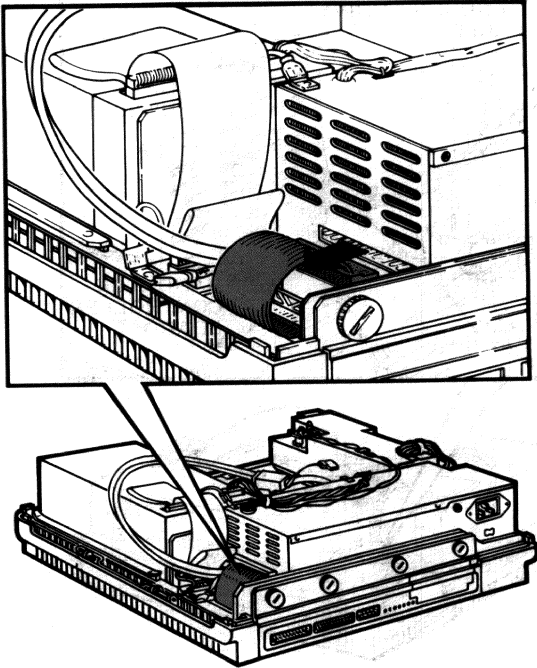

Figure 5-34 Unplugging Power Cable from Power Supply

8. Unplug the hard disk drive cable from the hard disk controller board (Figure 5-35).

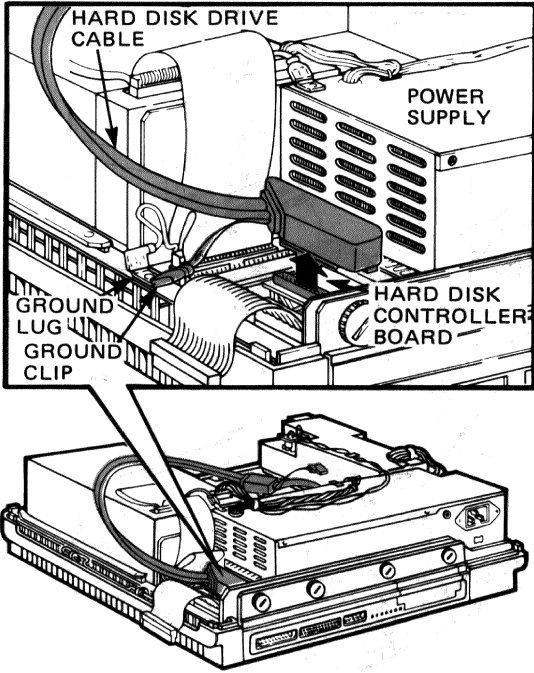

Figure 5-35 Unplugging Hard Disk Drive Cable from Controller

9. Unplug the power cable from the system module.
10. Unplug the diskette drive flat cable(s), Figure 5-36. Unplug the ground clip(s) from the ground lug. Fold the cable(s) over the top of the diskette drive.

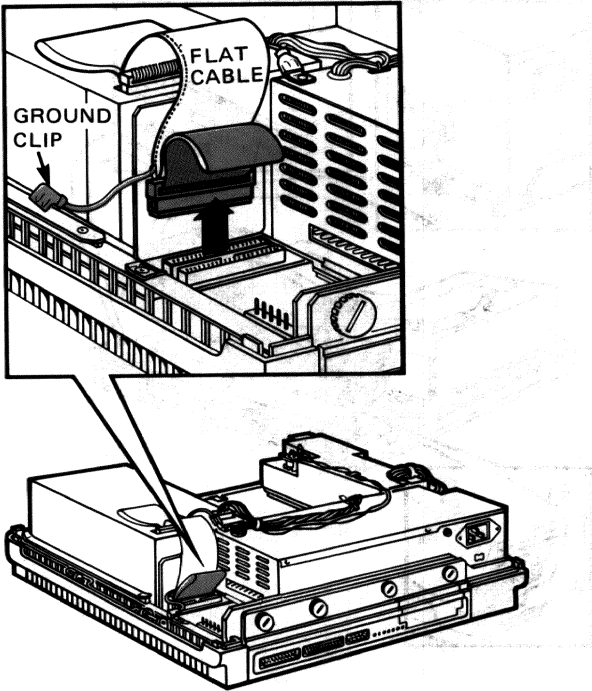

Figure 5-36 Unplugging Diskette Drive Flat Cable(s)

11. Slide or lift the latch on the side of the power supply, as shown in Figure 5-37.
12. Lift the end of the power supply up as shown in Figure 5-37 and remove it.

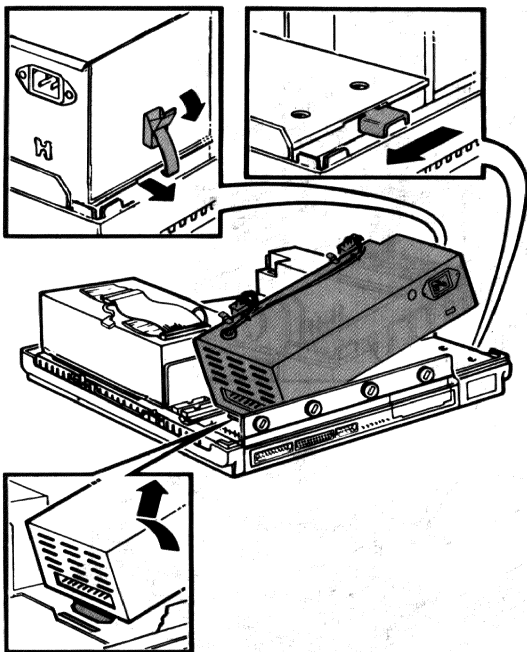

Figure 5-37 Removing the Power Supply

To install a power supply, reverse steps 1 through 12 above.

CAUTION

On a new power supply, check the voltage selector switch, shown in Figure 5-38, to make sure it is set correctly for the power at the wall receptacle.

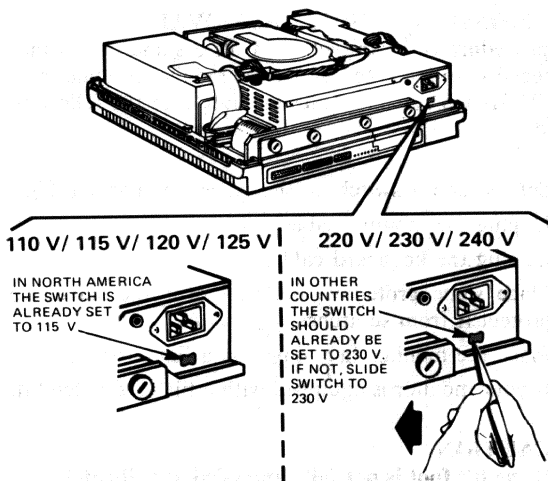

Figure 5-38 Check Voltage Setting

5.21 MONITOR REMOVAL

Perform the following steps to remove the monitor.

WARNING

For your safety, make sure the power is OFF.

1. Switch off the power supply if you have a color video monitor.
2. Unplug the power cable.
3. Unplug the monitor cable.
4. Unplug the keyboard cable and remove the monitor.

After you remove the old monitor, pack it in its original protective material for shipping or storage. To install a new monitor reverse steps 1 through 4. When you are finished, clean the screen of the new monitor with the recommended cleaning solution or isopropyl alcohol.

5.22 MONITOR MODULE REMOVAL

This procedure is for branch field offices and others that are specially equipped to remove the monitor module from the VR201-A black and white monitor. Use the following procedure.

1. Set the power switch on the system unit to 1 (off).
2. Unplug the monitor cable.
3. Unplug the keyboard cable.
4. Place some protective material over the screen to protect it from scratches.
5. Place the monitor face down on a flat surface.
6. If your monitor is equipped with a tilt foot, extend it.

CAUTION

If the tilt foot is not fully extended, it will catch on the internal wires of the video monitor when you remove the cover.

7. Remove the screw cap from the back of the monitor (Figure 5-39).
8. Unscrew the cover retaining screw and remove it (Figure 5-39).
9. Slide the cover off and place it to one side.

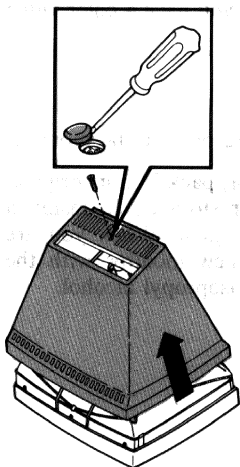

Figure 5-39 Monitor Cover Removal

WARNING

The monitor holds a charge of over 12,000 V and, before you remove the monitor module, you must, for your safety, turn the power OFF.

When changing the monitor module, use extreme care, especially around the following high voltage parts, shown in Figure 5-40.

- Anode and anode wire
- Flyback transformer
- Connector at neck of CRT

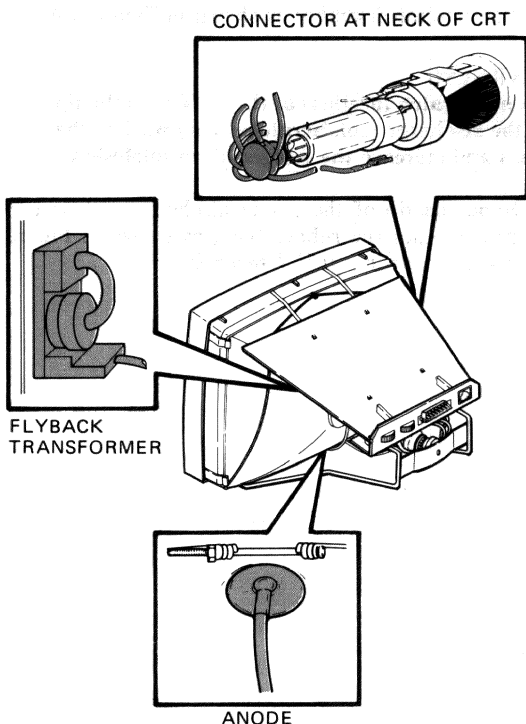

Figure 5-40 Sources of High Voltage

10. Discharge the anode connection of the CRT by performing the following steps.

NOTE

The high voltage at the anode will normally discharge by itself over a short period of time when the power is turned off; however, this discharge procedure is necessary in case there is a problem in the high voltage power supply on the monitor module that prevents it from discharging by itself.

- a. Clip the anode discharge tool to the wire frame of the monitor assembly as shown in Figure 5-41.

WARNING

Do not scratch the glass of the CRT with the tip of the discharge tool. Scratches may weaken the glass and increase the danger of an implosion.

- b. Slide the tip of the anode discharge tool or test probe under the rubber boot, as shown in Figure 5-41. Hold for a *full 3 seconds*.

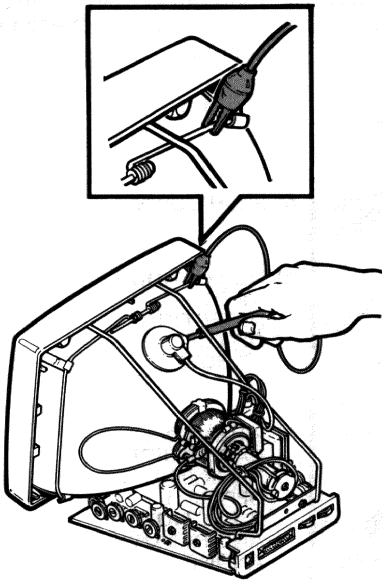

Figure 5-41 Discharging CRT Anode

11. Disconnect the anode wire from the CRT by pushing the anode further into its socket. Rock it from side to side and roll it out as shown in Figure 5-42.

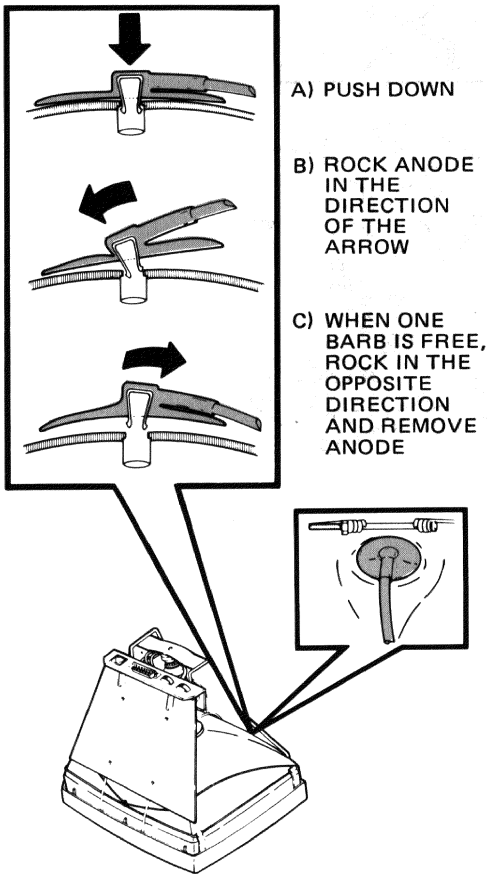

Figure 5-42 Anode Removal

12. Unplug the connector from the neck of the CRT as shown in Figure 5-43.

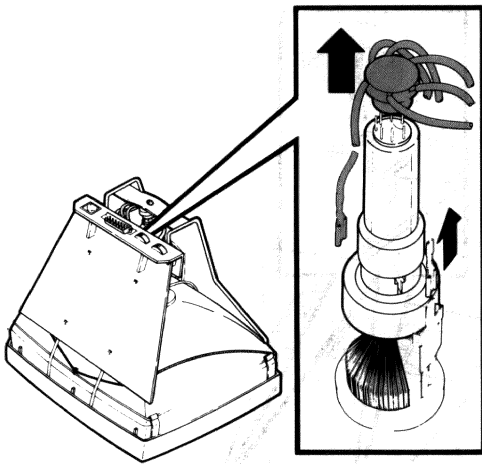

Figure 5-43 Removing CRT Connector

13. Unplug the associated white ground wire from the lug on the neck of the CRT. Also remove the white ground wire from the chassis frame.

14. Remove the rear panel from the edge of the monitor module as shown in Figure 5-44.

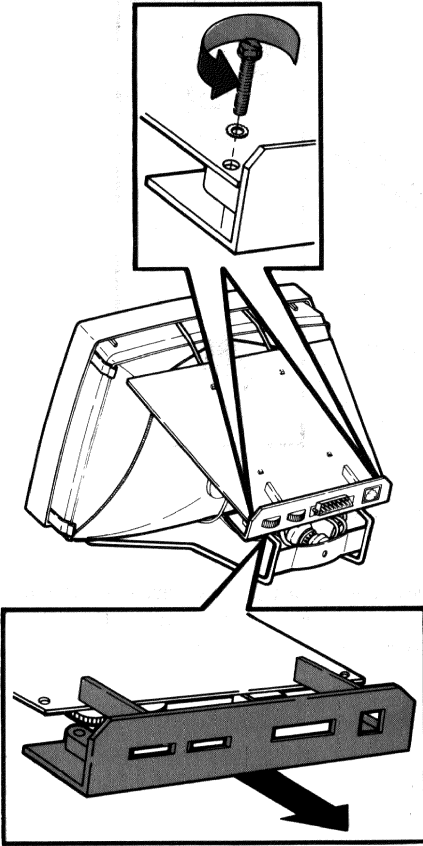

Figure 5-44 Monitor Module Rear Panel Removal

15. With needlenose pliers, release the standoffs holding the module as shown in Figure 5-45. Do not worry if the standoffs break; the new module comes with new standoffs.
16. Remove the 4-wire connector from the center of the monitor module.

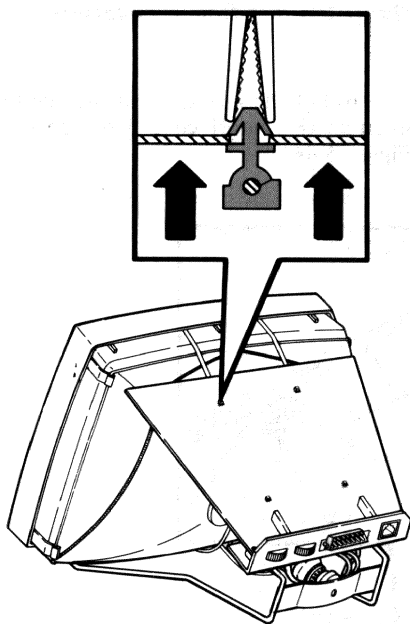

Figure 5-45 Monitor Module Standoff Removal

5.23 MONITOR MODULE REPLACEMENT

To install a new monitor module, you should perform the following steps.

WARNING

Discharge the anode wire of the new module by touching it to the white ground wire on the new module. The new module may contain a stored high voltage charge left over from manufacturing testing.

1. Set the cutoff control of the new monitor module to the same position as the cutoff control on the old module. See Figure 5-46.

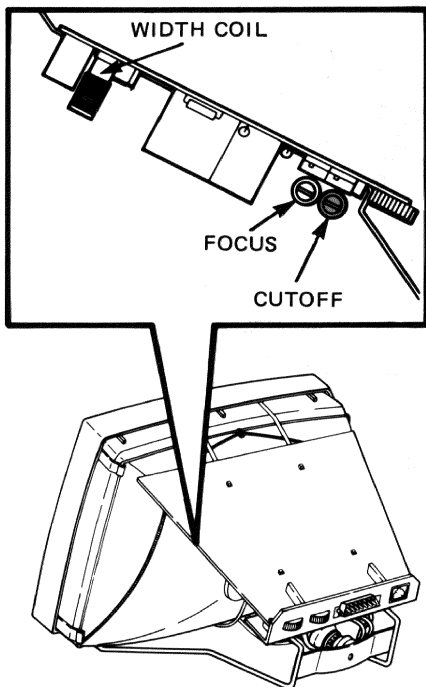

Figure 5-46 Monitor Module Cutoff Control

2. Replace any broken standoffs.
3. Plug the connector (6 wires) into the center of the monitor module.
4. Connect one of the two white ground wires from the connector to the lug on the neck of the CRT.
5. Connect the other white ground wire from the connector to the chassis frame.
6. Install the monitor module on the standoffs.
7. Install the monitor module rear panel.
8. Reconnect the anode wire to the CRT.
9. Before installing the cover, connect the keyboard cable and the monitor cable from the system unit.
10. Connect the power cord to the color video monitor.
11. Set the color video monitor power switch to 1 (on).
12. Set the system unit power switch to 1 (on).
13. Boot the diagnostic diskette. From the Individual Test menu, select subtest Video Alignment Pattern. See Chapter 3 for the procedure to run the Rainbow diagnostic diskette.
14. Look at the display and adjust the monitor according to the procedures in Chapter 4.
15. After adjustment, install the monitor cover and reconnect the cables to the keyboard and system unit.
16. When you are finished, clean the monitor screen with a glass cleaning solution or isopropyl alcohol.

THE UNIVERSITY OF CHICAGO LIBRARY

THE UNIVERSITY OF CHICAGO LIBRARY

THE UNIVERSITY OF CHICAGO LIBRARY

THE UNIVERSITY OF CHICAGO LIBRARY

THE UNIVERSITY OF CHICAGO LIBRARY

THE UNIVERSITY OF CHICAGO LIBRARY

THE UNIVERSITY OF CHICAGO LIBRARY

THE UNIVERSITY OF CHICAGO LIBRARY

THE UNIVERSITY OF CHICAGO LIBRARY

THE UNIVERSITY OF CHICAGO LIBRARY

THE UNIVERSITY OF CHICAGO LIBRARY

THE UNIVERSITY OF CHICAGO LIBRARY

THE UNIVERSITY OF CHICAGO LIBRARY

THE UNIVERSITY OF CHICAGO LIBRARY

THE UNIVERSITY OF CHICAGO LIBRARY

THE UNIVERSITY OF CHICAGO LIBRARY

THE UNIVERSITY OF CHICAGO LIBRARY

THE UNIVERSITY OF CHICAGO LIBRARY

THE UNIVERSITY OF CHICAGO LIBRARY

THE UNIVERSITY OF CHICAGO LIBRARY

THE UNIVERSITY OF CHICAGO LIBRARY

THE UNIVERSITY OF CHICAGO LIBRARY

THE UNIVERSITY OF CHICAGO LIBRARY

THE UNIVERSITY OF CHICAGO LIBRARY

THE UNIVERSITY OF CHICAGO LIBRARY

THE UNIVERSITY OF CHICAGO LIBRARY

THE UNIVERSITY OF CHICAGO LIBRARY

THE UNIVERSITY OF CHICAGO LIBRARY

THE UNIVERSITY OF CHICAGO LIBRARY

THE UNIVERSITY OF CHICAGO LIBRARY



A RAINBOW COMPUTER PARTS LIST

Table A-1 lists the recommended spare parts for the Rainbow computer. For a more detailed parts list, refer to the *PC100 Rainbow™ 100 System Unit Illustrated Parts Breakdown*, EK-SB100-IP.

Table A-1 Rainbow Computer Parts List

Part	Digital Part Number
System module, PC100A*	70-19974-00
System module, PC100B	70-19974-02
RX50 controller module	54-15482
Hard disk controller board	54-16019
64K byte memory board (PC100A)†	PC1XX-AA
192K byte memory board (PC100A)†	PC1XX-AB
128K byte memory board (PC100B)	PC1XX-AC
256K byte memory board (PC100B)	PC1XX-AD
64K byte memory component kit (9 chips) PC100B	PC1XX-AY
256K byte memory component kit (9 chips) PC100B	PC1XX-AZ
Color/graphics option board	54-15688
Extended communications option board	54-15703
ROM 0 PC100B	23-022E5-00
ROM 1 CLUSTER 1 (German, French, English) PC100B	23-020E5-00
ROM 1 CLUSTER 2 (Dutch, French, English) PC100B	23-015E5-00
ROM 1 CLUSTER 3 (Finnish, Swedish, English) PC100B	23-016E5-00
ROM 1 CLUSTER 4 (Danish, Norwegian, English) PC100B	23-017E5-00
ROM 1 CLUSTER 5 (Spanish, Italian, English) PC100B	23-018E5-00
Canadian (French) language ROM*	BG-R873A-BV
British (UK) language ROM*	BG-R876A-BV
German/Austrian language ROM*	BG-R878A-BV
Italian language ROM*	BG-R874A-BV

*Part is for the Rainbow PC100A version only.

†This memory board can be used on either the Rainbow PC100A or PC100B versions.

Table A-1 Rainbow Computer Parts List (Cont)

Part	Digital Part Number
Swiss (French) language ROM*	BG-R376A-BV
Swiss (German) language ROM*	BG-R375A-BV
Belgian/French language ROM*	BG-R877A-BV
Spanish language ROM*	BG-R377A-BV
Dutch language ROM*	BG-R881A-BV
U.S.A. language ROM*	70-20274-15
Belgian/Flemish language ROM*	BG-R378A-BV
Danish language ROM*	BG-R875A-BV
Finnish language ROM*	BG-R872A-BV
Norwegian language ROM*	BG-R879A-BV
Swedish language ROM*	BG-R880A-BV
Power supply - PC100A*	H7842-A
Power supply - PC100B†	H7842-D
COMM connector loopback plug - PC100A*	12-15336-01
EXT COMM B loopback plug/ COMM connector - PC100B	12-15336-04
PRINTER connector loopback plug	29-24631-00
RX50 diskettes (pack of ten)	RX50K-10
RX50 dual-diskette drive	RX50-AA
Keyboard, American (English)	LK201-AA
Keyboard, British (English)	LK201-AE
Keyboard, Belgian/French	LK201-AP
Keyboard, Belgian/Flemish	LK201-AB
Keyboard, Canadian (French)	LK201-AC
Keyboard, Danish	LK201-AD
Keyboard, Finnish	LK201-AF
Keyboard, German/Austrian	LK201-AG
Keyboard, Dutch	LK201-AH
Keyboard, Italian	LK201-AI
Keyboard, Norwegian	LK201-AN
Keyboard, Spanish	LK201-AS
Keyboard, Swedish	LK201-AM
Keyboard, Swiss (French)	LK201-AK
Keyboard, Swiss (German)	LK201-AL
Keycap removal tool	74-27314-01
Video monitor assembly (white phosphor)	VR201-A
Color monitor	VR241-A
Cable, color monitor	BCC17
Cable, hard disk drive	17-00427-01
Cable, monitor, 1.8 m (6 ft)	17-00283-00
Cable, power supply to system module, 10.1 cm (4 in)	17-00318-02
Cable, RX50 shielded, 20.3 cm, (8 in)	17-00317-03
Cable, RX50 shielded, 36.8 cm (14.5 in)	17-00317-04

Table A-1 Rainbow Computer Parts List (Cont)

Part	Digital Part Number
Cable, COMM printer, 3 m (10 ft)	BCC04-10
Cable, modem	BCC15
Fan bracket assembly, PC100A*	70-19572-00
Fan bracket assembly, PC100B	70-20816-01
Line cord, Australia	17-00198-00
Line cord, Belgium	17-00199-00
Line cord, Canada (French)	17-00083-09
Line cord, Denmark	17-00310-01
Line cord, Finland	17-00199-00
Line cord, France	17-00199-00
Line cord, Germany	17-00199-00
Line cord, Holland	17-00199-00
Line cord, Italy	17-00199-00
Line cord, Japan	17-00083-09
Line cord, Norway	17-00199-00
Line cord, Spain	17-00199-00
Line cord, Sweden	17-00199-00
Line cord, Switzerland (French)	17-00210-00
Line cord, Switzerland (German)	17-00210-00
Line cord, United Kingdom	17-00209-00
Line cord, U.S.A.	17-00083-09
Cable, keyboard	17-00294-00
Connector clip, RX50 controller	74-28702-01
Connector clip, RD51 controller	74-28702-02
Standoffs, module	12-19857-01
Spacer, hard disk controller	74-29164-01
Filler panel, PC100	74-27174-01
Rainbow 100 medallion*	74-27256-03
Video alignment template	29-24371-00
Packaging container for RD51	99-90045-01

*Part is for the Rainbow PC100A version only.

†This power supply is also used on the PC100A with the Winchester upgrade kit.

... ..

... ..

... ..

... ..

... ..

... ..

... ..

... ..

... ..

... ..

... ..

... ..

... ..

... ..

... ..

... ..

... ..

... ..

... ..

... ..

... ..

... ..

... ..

... ..

... ..

... ..

... ..

... ..

... ..

... ..

B MEMORY OPTION TEST PROCEDURE

B.1 INTRODUCTION

This procedure provides information you should follow to test the Rainbow memory board when you first install it, or when you increase the size of the memory. This procedure determines if you installed your memory board correctly, or if you installed the memory upgrade chips correctly. In addition, if you suspect the memory board is faulty, you can use this procedure to check and test the memory board.

B.1.1 Turning on the Computer (PC100B only)*

Set the power switch to 1 (on).

The first time you turn on your Rainbow computer after installing a memory board or changing its memory size, the monitor should display the following message. (The letters nnnK represent your total memory size.)

See Owner's Manual - MESSAGE 24 - New Memory Size
= nnnK

The computer displays this message only once, and shortly thereafter displays the Main System Menu, shown in Figure B-1.

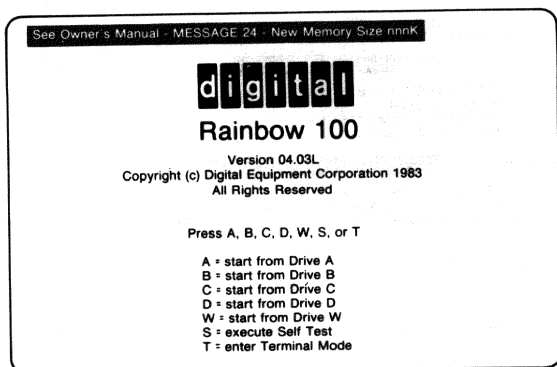

Figure B-1 Main System Menu with Message

* Refer to Chapter 2 (Paragraph 2.2.7) to set the memory size for the PC100A version of the Rainbow computer.

Compare the new memory size displayed with the total memory expected. Refer to page 3 in the *Rainbow™ Memory Board Option Installation Guide*.

If the system displays either of the following messages, disregard the message and continue with this procedure.

MESSAGE 27 - Memory Board

MESSAGE 2 - Main Board

To continue with this test procedure, you must display the Main System Menu. Press the **Set-Up** key, then press **<Ctrl/Set-Up>** to display the Main System Menu.

NOTE

If the computer does not display the Main System Menu, refer to Chapter 3 of this guide.

B.1.2 PC100A Memory Board Options

To set the memory size for the PC100A Rainbow version memory board options, refer to Paragraph 2.2.7 of this guide.

B.2 TEST PROCEDURE

Find the Rainbow diagnostic diskette in the system kit. Insert this diskette in diskette drive A and close the door. Type A and press the **Return** key. The computer displays the Main Diagnostic Menu (Figure B-2).

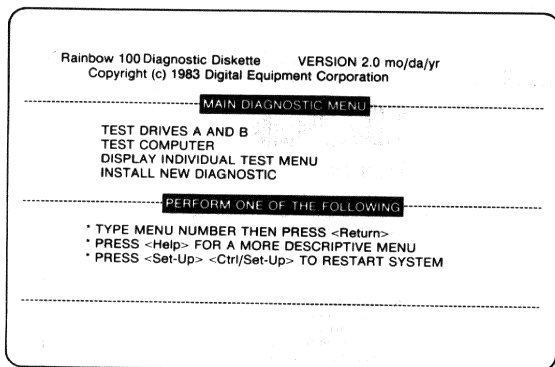

Figure B-2 Main Diagnostic Menu

Type 3 and press the **Return** key to display the Individual Test menu (Figure B-3).

INDIVIDUAL TEST MENU	
[1] MEMORY (8088)	[9] KEYBOARD
[2] MEMORY (8088/Z80)	[10] MEMORY (SET-UP)
[3] VIDEO CONTROLLER	[11] COMM/PRINTER EXT.LOOPBACK
[4] DISK SYSTEM	[12] SYSTEM INTERACTION
[5] COMM/PRINTER/KEYBOARD PORT	
[6] PRINTER CONFIDENCE	[14] COMMUNICATIONS OPTION
[7] VIDEO ALIGNMENT PATTERN	[15] GRAPHICS OPTION
[8] MEMORY (Z80)	[16] WINCHESTER OPTION
PERFORM ONE OF THE FOLLOWING	
<ul style="list-style-type: none"> * TYPE MENU NUMBER THEN PRESS <Return> * PRESS <Help> FOR A MORE DESCRIPTIVE MENU * PRESS <Set-Up> <Ctrl/Set-Up> TO RESTART SYSTEM 	

Figure B-3 Individual Test Menu

Type 1 and press the **Return** key to select the first test: **MEMORY (8088)**.* The test begins by sizing the memory and checking for correct installation of the memory chips. The computer displays the screen shown in Figure B-4.

INDIVIDUAL DIAGNOSTIC TEST: MEMORY (8088) (REV 2.0)
SYSTEM MEMORY SIZE = nnnk

Figure B-4 Individual Diagnostic Test

* If you receive a Memory Utility Program diskette with the new memory module, do not use the MEMORY (8088) test. Use the new diskette.

B.2.1 A Successful Test

If the system memory size displayed is the same as your total memory size and the test is successful, the computer displays the Main Diagnostic Menu with the following message at the bottom of the screen (see Figure B-5).

PREVIOUSLY RUN INDIVIDUAL TEST - PASSED

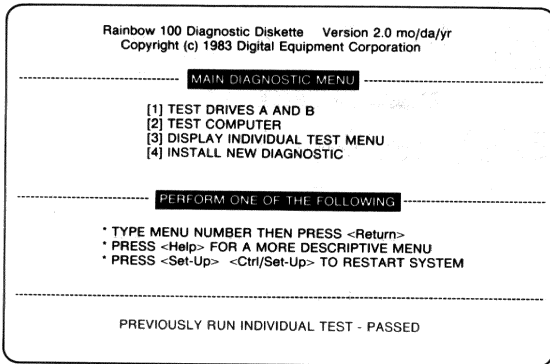

Figure B-5 Main Diagnostic Menu with Test-Passed Message

NOTE

The memory test may take 30 minutes, depending on the size of your memory.

B.2.2 An Unsuccessful Test

If a memory chip is inserted backward, has a bent leg, is the wrong size, or is faulty, the system displays a failure message at the bottom of the screen (see Figure B-6). If the memory board has the wrong switch settings, the system will display a failure message.

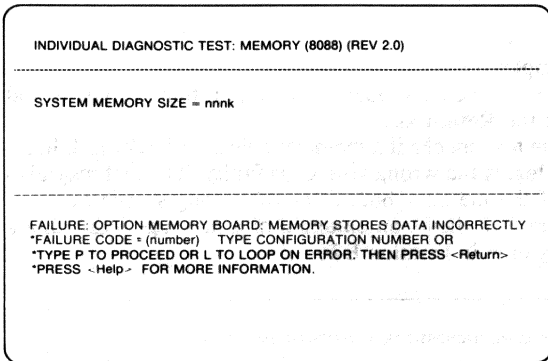

Figure B-6 Individual Diagnostic Test with a Failure Message

If you see the message:

**FAILURE: OPTION MEMORY BOARD:
MEMORY SIZING INCORRECT**

type **P** to proceed, as many times as requested, until the test starts running. If "FAILURE CODE = nn" is displayed, record the number then read the next section.

B.2.2.1 Determine the Failing Chip – If you have just added a new memory board, your configuration number is either 1 or 2, as found on page 2 of your *Rainbow™ Memory Board Option Installation Guide*. If you have added a set of memory upgrade chips, you must determine a new configuration number. Refer to Paragraph B.3 to determine this number.

Type the configuration number and press the **Return** key.

Example:

If your memory board is configuration 2, type **2** and press the **Return** key.

The test checks if a memory chip is in backward, has a bent leg, is the wrong size, or is faulty. The test may also fail if the memory board has the wrong switch settings. Figure B-7 shows an example of a message indicating a faulty chip in location E26.

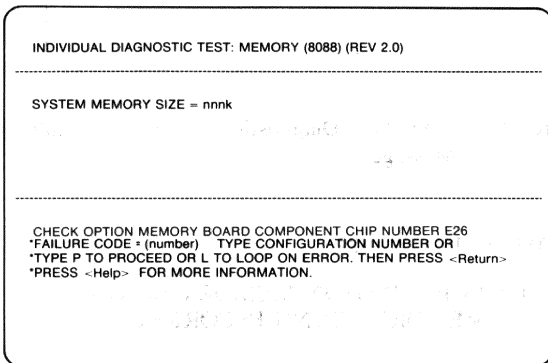

Figure B-7 Individual Diagnostic Test with a Faulty Memory Component Message

NOTE

If you do not know the configuration of your memory board, you must remove the power cord from the Rainbow computer and remove the memory board from the system module to look at the configuration. (See Paragraph 5.6.)

B.2.2.2 Identify the Chip Location – Find the E number displayed on your screen and mark it in the Figure B-8.

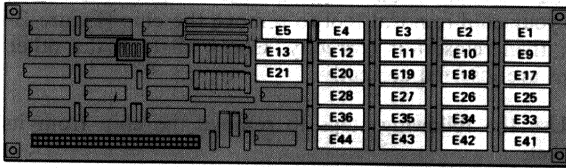

Figure B-8 Memory Board Chip Location Map

B.2.2.3 Remove the Memory Board – Set the power switch to 0 (off), unplug the power cord, and remove the system module, as described in Paragraph 5.4. Press outward on the three standoffs and remove the memory board from the system module as shown in Figure B-9.

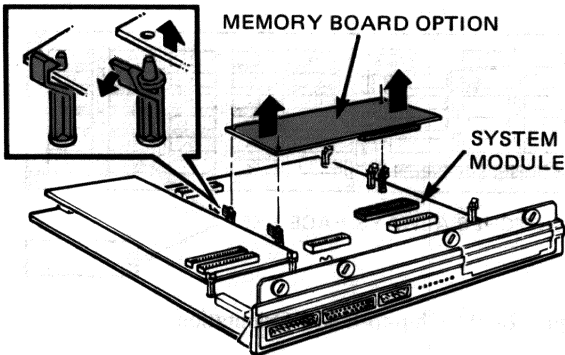

Figure B-9 Memory Board Option Removal

B.2.2.4 If the Chip is in Backward – Place the memory board option in front of you as shown in Figure B-10. Locate the notch on the end of the chip. If the notch is facing the opposite direction than the others on the board, use your chip removal tool to remove the chip (Figure B-11); then reinsert it correctly. Check that all the other chips are inserted correctly.

Use the following steps to remove the chip from its socket.

1. Use the removal tool provided in the upgrade kit. Place the hooked edges of the tool between the memory chip and the socket, as shown. Gently rock the chip from left to right until it is loose in the socket.
2. To prevent the legs from bending, use one hand to lift the removal tool and chip, and the other hand to hold down the memory board. Raise the chip straight up and out of the socket. After correcting the fault, install the memory chip correctly.

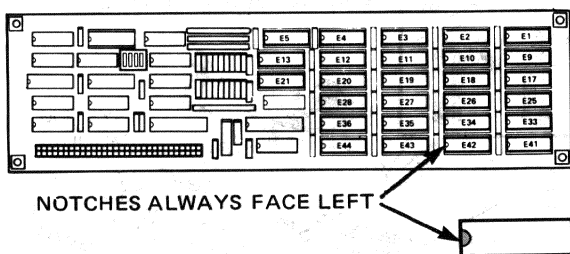

Figure B-10 Chip-to-Board Orientation

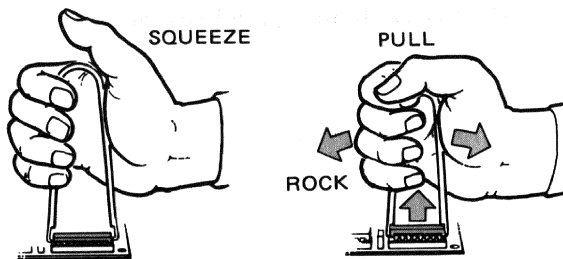

Figure B-11 Chip Removal

CAUTION

Memory chips can be damaged by static electricity if they are not handled carefully. Keep the memory chips on your spare board until you are ready to install them on the new module. Use a static discharge kit, such as a Velostat® kit (part number 29-11762), when handling memory chips and the memory module.

B.2.2.5 Chip with Bent Leg – If you find a bent leg on the chip, use your chip removal tool to remove the chip. Straighten each leg of the chip, then reinsert the chip, taking care not to bend the legs.

B.2.2.6 Check Chip Size – Check that all nine chips in each bank are the same size. Check the number, either 64 or 256, on the chips in each bank (see Figure B-12). They must have the same number within each bank, but may differ from another bank. For example, 64K chips may be in bank 1, and 256K chips may be in bank 2.

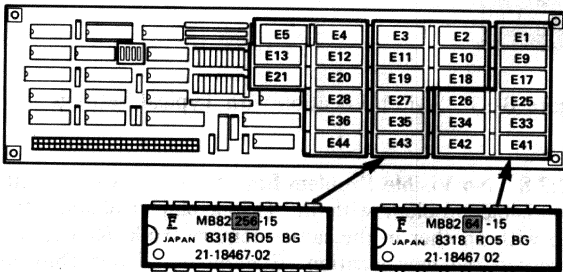

Figure B-12 Chip Size Identification

B.2.2.7 Check Memory Board Switch Setting – Check the memory board switch for the correct setting as shown in Figure B-13. Go to Paragraph B.3 to check your switch settings or check your switches with the following table.

Memory Bank	Switch Position	64K Chips	256K Chips
1	1	OFF	ON
2	2	OFF	ON
3	3	OFF	ON
	4*	ON	ON

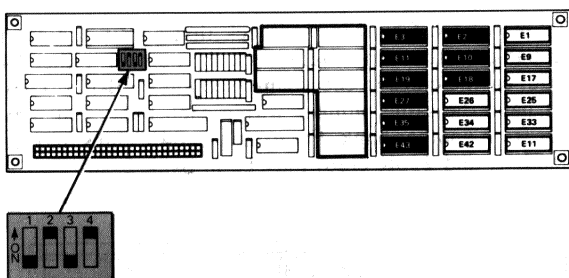

Figure B-13 Switch Location with Typical Settings

B.2.2.8 No Visible Problem Found – If you cannot find any visible problem with the failing chip, exchange the chip with another in the same memory bank. Remember to record the new location (E number) of this chip on Figure B-8.

Install the memory board in your computer and run this test procedure again. If the test fails at the new memory chip location, return the upgrade kit or memory option to the dealer. Remember to ship the memory board in its original protective packing material and shipping box.

B.2.2.9 Rerun Memory Test – After replacing a faulty chip, return to Paragraph B.2 and rerun the MEMORY (8088) test from the Individual Test menu on the Rainbow diagnostic diskette. This test will only find one failure at a time. Therefore, you must remove and replace each chip that causes the test to fail, then run the test again.

Continue running the test until it is successful.

*Factory set. Must always remain ON.

B.3 CONFIGURATIONS

If you do not know your configuration number, remove the memory board from the system module. Refer to Paragraph B.2.2.3.

Place the memory board in front of you as shown in Figure B-14.

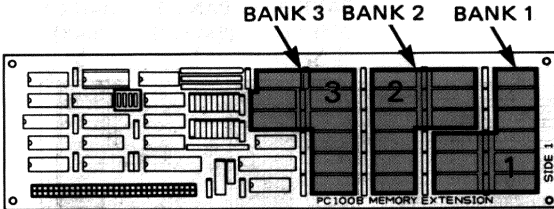

Figure B-14 Chip Bank Identification

Determine the size of the memory chips, 64 or 256, in each bank by comparing them to Figure B-15.

NOTE

The exact letters and numbers on the chips and their locations may be different on your memory board; however, the size numbers must be the same within each bank.

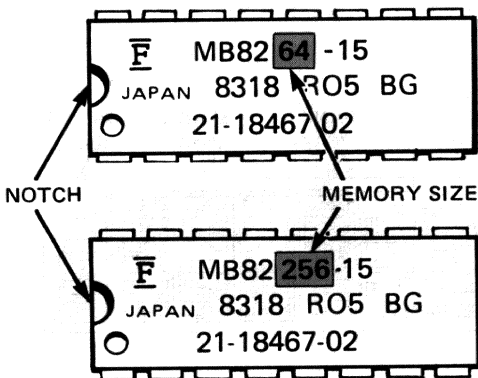

Figure B-15 Memory Chip Size

Compare your memory board chip sizes and locations to the eight configurations shown in Figures B-16 through B-23 on the following pages.

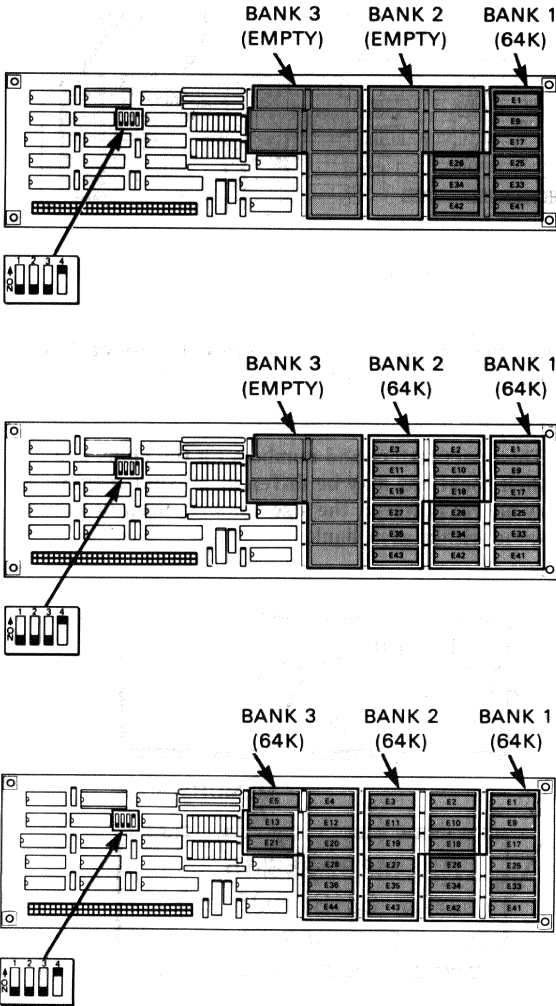

Figure B-16 Configuration 1

Once you find your configuration number, write it down on page 2 of your *Rainbow™ Memory Board Option Installation Guide* for future reference.

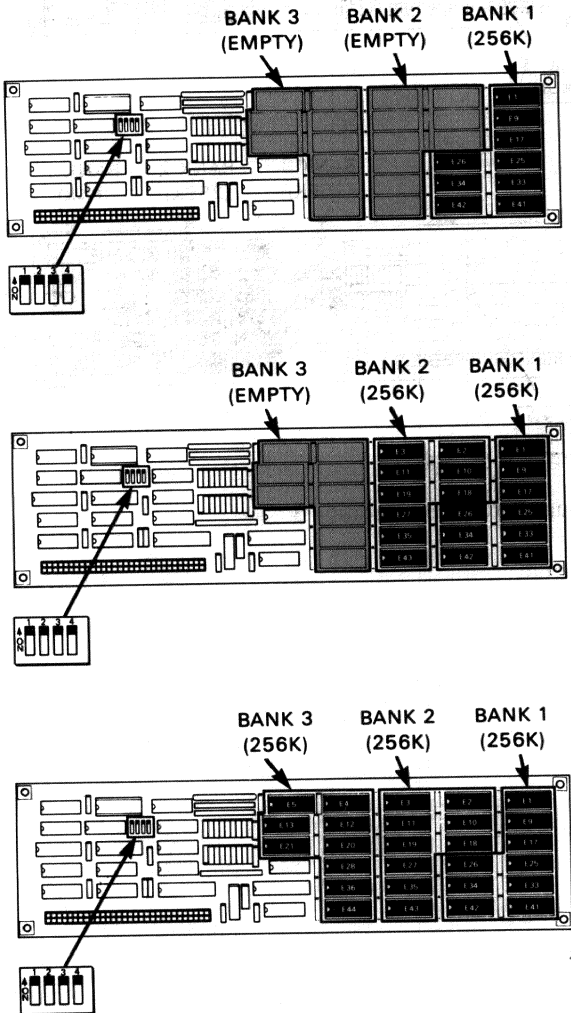

Figure B-17 Configuration 2

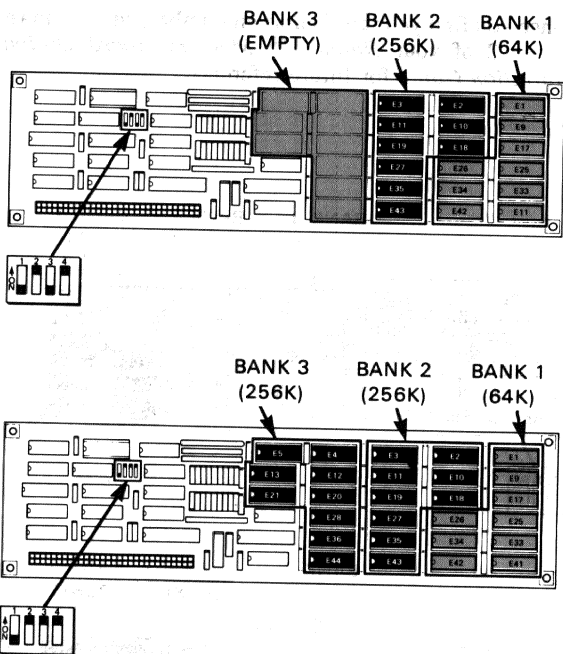

Figure B-18 Configuration 3

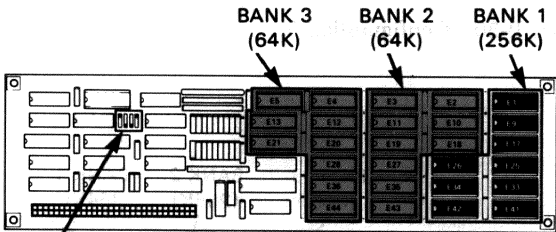
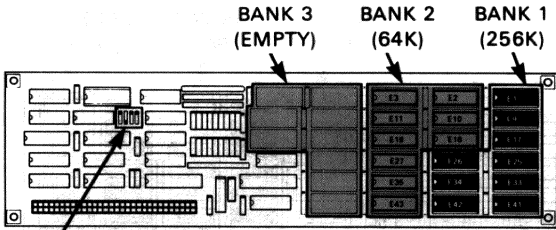

Figure B-19 Configuration 4

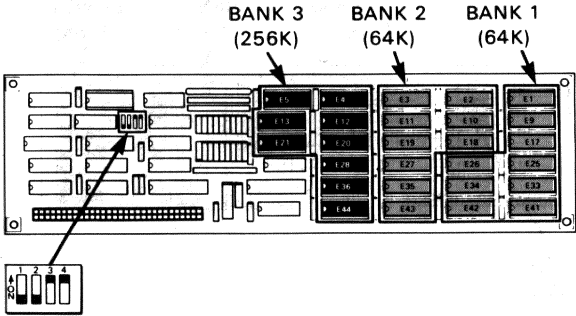

Figure B-20 Configuration 5

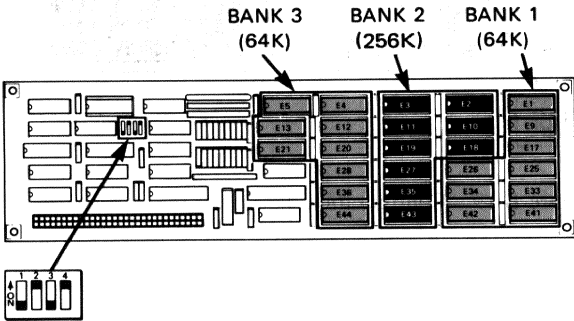

Figure B-21 Configuration 6

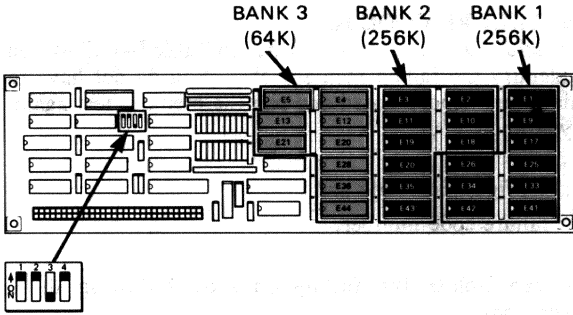

Figure B-22 Configuration 7

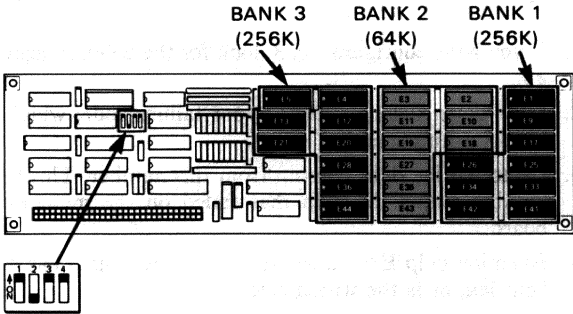

Figure B-23 Configuration 8

B.4 FAILURE CODE KEY

The failure code numbers provided in Table B-1 allow you to identify the failing memory chip. You do not have to install the memory board and run the memory test again. If you know your:

1. configuration code and
2. failure code number,

you can isolate the failing chip by following these instructions.

Look for your configuration number in the top row of the table. Next, find your failure code in your configuration number column. Then, move to the far right in the failure code row and locate the failing E number in the E NUM column.

Example:

1. If you have configuration 3, look for the column head #3.
2. Look down this column for your failure code, which in this example is 70.
3. Go to the far right column from this number. This E number shows the chip that failed on the memory board.
4. Examine chip E36 to see if it is in backward, has a bent leg, or is the wrong size.

The location of the E number for this example is shown in Figure B-24.

Once you have corrected your failing chip, install your memory board and run this memory test procedure again until it is successful.

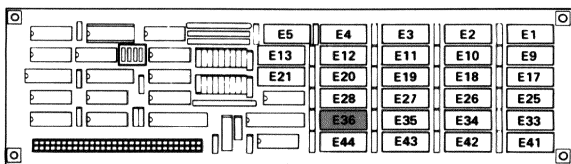

Figure B-24 Memory Board Chip Location

Table B-1 Failure Code Table

	CONFIGURATION NUMBERS				E NUM
	#1	#2	#3	#4	
20	20 30 40 50	20	20 30 40 50	34	
21	21 31 41 51	21	21 31 41 51	26	
22	22 32 42 52	22	22 32 42 52	41	
23	23 33 43 53	23	23 33 43 53	33	
24	24 34 44 54	24	24 34 44 54	25	
25	25 35 45 55	25	25 35 45 55	17	
26	26 36 46 56	26	26 36 46 56	9	
27	27 37 47 57	27	27 37 47 57	1	
28	28 38 48 58	28	28 38 48 58	42	
30	60 70 80 90	30 40 50 60	60	35	
31	60 70 80 90	31 41 51 61	61	27	
32	62 72 82 92	32 42 52 62	62	19	
33	63 73 83 93	33 43 53 63	63	11	
34	64 74 84 94	34 44 54 64	64	3	
35	65 75 85 95	35 45 55 65	65	18	
36	66 76 86 96	36 46 56 66	66	10	
37	67 77 87 97	37 47 57 67	67	2	
38	68 78 88 98	38 48 58 68	68	13	
40	A0 B0 C0 D0	70 80 90 A0	70	36	
41	A1 B1 C1 D1	71 81 91 A1	71	28	
42	A2 B2 C2 D2	72 82 92 A2	72	20	
43	A3 B3 C3 D3	73 83 93 A3	73	12	
44	A4 B4 C4 D4	74 84 94 A4	74	4	
45	A5 B5 C5 D5	75 85 95 A5	75	21	
46	A6 B6 C6 D6	76 86 96 A6	76	13	
47	A7 B7 C7 D7	77 87 97 A7	77	5	
48	A8 B8 C8 D8	78 88 98 A8	78	44	

FAILURE CODE NUMBERS

	CONFIGURATION NUMBERS				E NUM
	#5	#6	#7	#8	
20	20	20 30 40 50	20 30 40 50	34	
21	21	21 31 41 51	21 31 41 51	26	
22	22	22 32 42 52	22 32 42 52	41	
23	23	23 33 43 53	23 33 43 53	33	
24	24	24 34 44 54	24 34 44 54	25	
25	25	25 35 45 55	25 35 45 55	17	
26	26	26 36 46 56	26 36 46 56	9	
27	27	27 37 47 57	27 37 47 57	1	
28	28	28 38 48 58	28 38 48 58	42	
30	30 40 50 60	60 70 80 90	60	35	
31	31 41 51 61	61 71 81 91	61	27	
32	32 42 52 62	62 72 82 92	62	19	
33	33 43 53 63	63 73 83 93	63	11	
34	34 44 54 64	64 74 84 94	64	3	
35	35 45 55 65	65 75 85 95	65	18	
36	36 46 56 66	66 76 86 96	66	10	
37	37 47 57 67	67 77 87 97	67	2	
38	38 48 58 68	68 78 88 98	68	13	
40	50 60 70	70 A0	70 80 90 A0	36	
41	51 61 71	71 A1	71 81 91 A1	28	
42	52 62 72	72 A2	72 82 92 A2	20	
43	53 63 73	73 A3	73 83 93 A3	12	
44	54 64 74	74 A4	74 84 94 A4	4	
45	55 65 75	75 A5	75 85 95 A5	21	
46	56 66 76	76 A6	76 86 96 A6	13	
47	57 67 77	77 A7	77 87 97 A7	5	
48	58 68 78	78 A8	78 88 98 A8	44	

FAILURE CODE NUMBERS

1917

1917

1917

1917

1917

1917

1917

1917

1917

1917

1917

1917

1917

1917

1917

1917

1917

1917

1917

1917

1917

1917

1917



EXTENDED COMMUNICATIONS OPTION TEST PROCEDURE

C.1 INTRODUCTION

The extended communications option test procedure checks if the extended communications option board (54-15703) is installed correctly. The test procedure has both internal and external subtests. The internal subtests check most of the circuits on the board except for the line drivers for the EXT COMM B connector. The external subtests check these line drivers.

Before changing the extended communications option board, you should check that the external connector pins and the pins on the 40-pin connectors on the option board are not bent.

Reseat the option board and make sure that all the cable connectors on the system module are firmly in place, and that all the external cable connectors are secure.

Try testing the option board again, and if it fails, change the board.

C.2 TESTING

For these test procedures, you will need the option test diskette (BL-V174A-MV) and the loopback plug (12-15336-04).

Remove the option test diskette from its protective envelope and insert it into drive A.

C.2.1 Access Test

To start the diagnostic test, select the diskette drive that contains the option test diskette. Type A.

The computer displays the individual diagnostic test (Figure C-1) on the screen.

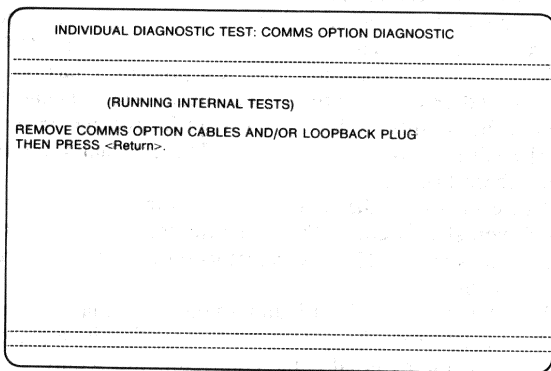

Figure C-1 Individual Diagnostic Test

NOTE

The communications option cables and/or loop-back plug should not be connected.

C.2.2 Starting Internal Tests

To start the internal tests, press the **Return** key. As the computer performs each internal subtest, its title displays on the screen followed by the result: **Passed** or **Failed**. As the internal tests are running, you will see a screen similar to the one shown in Figure C-2.

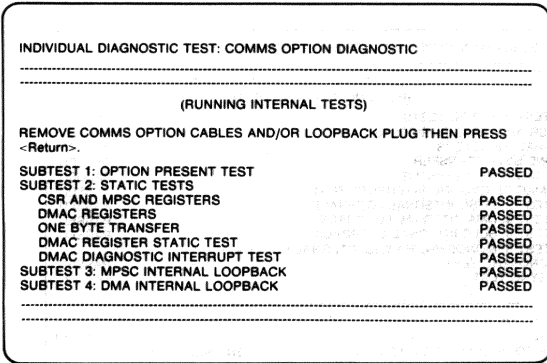

Figure C-2 Internal Tests Running

If an internal test fails, the system will display a message at the bottom of the screen showing which subtest failed. Figure C-3 shows a screen that reports a failed subtest with an explanatory error message. Write down the subtest number that failed and the error message, and refer to Paragraph C.3, or press the **Help** key for more error information.

```

INDIVIDUAL DIAGNOSTIC TEST: COMMS OPTION DIAGNOSTIC
-----
                                (RUNNING INTERNAL TESTS)
SUBTEST 2: STATIC TESTS                                     PASSED
  CSR AND MPSC REGISTERS                                   PASSED
  DMAC REGISTERS                                          PASSED
  ONE BYTE TRANSFER                                       PASSED
  DMAC BYTE TRANSFER                                      PASSED
  DMAC DIAGNOSTIC INTERRUPT TEST                          PASSED
SUBTEST 3: MPSC INTERNAL LOOPBACK                          PASSED
SUBTEST 4: DMA INTERNAL LOOPBACK                          PASSED
SUBTEST 5: SDLC INTERNAL LOOPBACK                         PASSED
SUBTEST 6: MONOSYNC/BISYNC INTERNAL LOOPBACK
  MONOSYNC TEST                                           PASSED
  BISYNC TEST                                              FAILED
-----
FAILURE: COMMUNICATIONS OPTION BOARD: SYNC DETECT FAILURE Ext. Comm A.
TYPE P TO PROCEED OR L TO LOOP ON ERROR, THEN PRESS <Return>:
PRESS <Help> FOR MORE ERROR INFORMATION.

```

Figure C-3 Internal Test Failure Message

To exit Help press the **Resume** key. Testing then restarts from the beginning.

C.2.3 Proceeding from an Error

You type **P** on the keyboard and press the **Return** key to continue the testing for each error encountered. If you type **L** and press the **Return** key, the message

LOOPING ON ERROR: % ERROR = nnn

replaces the previous message. The % ERROR is used to aid in troubleshooting intermittent problems.

After the test is performed 10 times, the percent failure is updated. To exit the loop, press the **Set-Up** key; then, press **<Ctrl/Set-Up>**. The system now displays the Main System Menu, and you will have to restart the testing procedures from the beginning.

When all of the internal tests are complete, the test stops and displays **INTERNAL TESTS COMPLETE**, as shown in Figure C-4.

```

INDIVIDUAL DIAGNOSTIC TEST: COMMS OPTION DIAGNOSTIC
-----
                                     (INTERNAL TESTS COMPLETE)

1200 BITS PER SECOND>                PASSED
1800 BITS PER SECOND>                PASSED
2000 BITS PER SECOND>                PASSED
2400 BITS PER SECOND>                PASSED
3600 BITS PER SECOND>                PASSED
4800 BITS PER SECOND>                PASSED
9600 BITS PER SECOND>                PASSED
19200 BITS PER SECOND>               PASSED
19200 BITS PER SECOND DIVIDED BY 32> PASSED
19200 BITS PER SECOND DIVIDED BY 64> PASSED

                                     (INTERNAL TESTS COMPLETE)

INSERT A LOOPBACK PLUG IN THE EXT COMM B CONNECTOR AND PRESS
<Return>
-----

```

Figure C-4 Internal Tests Complete

C.2.4 Starting External Testing

Insert the loopback plug in the EXT COMM B connector as shown in Figure C-5. To start the external testing, press

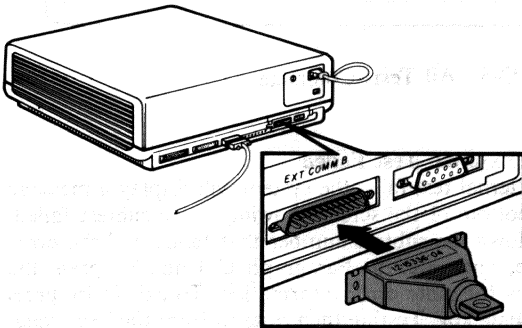

Figure C-5 Inserting Loopback Plug

the **Return** key. As the computer performs each external subtest, the subtest title and its result display on the screen. When all external tests are complete, the statement

TO REPEAT TESTS, PRESS <Return>:
OTHERWISE, REMOVE DISKETTE.

displays on the screen as shown in Figure C-6.

- Remove the option test diskette.
- Remove the loopback plug.

```

INDIVIDUAL DIAGNOSTIC TEST: COMMS OPTION DIAGNOSTIC
-----
                                (EXTERNAL TESTS COMPLETE)
19200 BITS PER SECOND>                PASSED
19200 BITS PER SECOND DIVIDEND BY 32>  PASSED
19200 BITS PER SECOND DIVIDEND BY 64>  PASSED
                                (INTERNAL TESTS COMPLETE)
INSERT A LOOPBACK PLUG IN THE EXT COMM B CONNECTOR AND PRESS
<Return>.
Subtest 9: EXTERNAL COMMS SIGNAL        PASSED
Subtest 10: EXTERNAL LOOPBACK           PASSED
Subtest 11: IDLE DETECT                  PASSED
                                (ALL TESTS COMPLETE)
TO REPEAT TESTS PRESS <Return>: OTHERWISE, REMOVE DISKETTE.
-----

```

Figure C-6 All Tests Complete

C.2.5 External Test Failed

If an external test fails, the system will display a message at the bottom of the screen showing which subtest failed. Write down the subtest number that failed and the error message, and refer to Paragraph C.3 and/or press the **Help** key for more error information. To exit Help, press the **Resume** key. Testing then restarts from the beginning.

C.3 FAULTS, ERROR MESSAGES, AND CORRECTIVE ACTION

The Help message screens referred to in this section will only appear when a fault is present and you press the **Help** key. They cannot be accessed by any other means.

Internal Test Error Message	Error Indicates	Corrective Action
FAILURE: COMM OPTION BOARD: (followed by:)	Option not detected by the system.	See Figure C-7.
COMM OPTION NOT INSTALLED -		

FAILURE: COMM OPTION BOARD: COMM OPTION NOT INSTALLED SCREEN 1 OF 1

The system does not detect the presence of the COMM option. It may be that the COMM option has not been properly installed.

INSTRUCTIONS FOR REMOVING AND INSTALLING THE COMM OPTION ARE FOUND IN THE EXTENDED COMM OPTION INSTALLATION GUIDE (EK-PCXC-IN).

1. Verify that the COMM option has indeed been installed.
2. Reseat the COMM option by removing and then reinstalling it.
3. Now re-run this test again to see if that fixed the problem.
4. If this error persists, you may need to replace the COMM option module. Please call one of the Help Line numbers listed in your Rainbow-100 Owner's Manual for further help. To exit press <Resume>. To rerun test press <Main Screen>.

Press <Next Screen> for more information

Figure C-7

Internal Test Error Message	Error Indicates	Corrective Action
FAILURE: COMM OPTION BOARD: (followed by:)		
Ext. Comm A BUFFER COMPARE ERROR	Received and transmitted data not identical.	
Ext. Comm B BUFFER COMPARE ERROR		
SYNC DETECT Ext. Comm A	Multiprotocol serial connector not synchronized.	See Figures C-8 and C-9.
SYNC DETECT Ext. Comm B		
DMA TERMINAL COUNT CHANNEL 0	Data transfers not completed during allotted time.	
DMA TERMINAL COUNT CHANNEL 2		

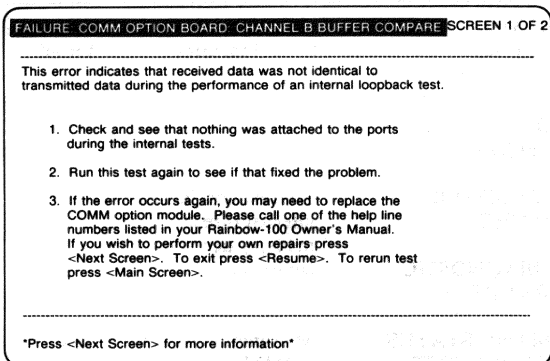

Figure C-8

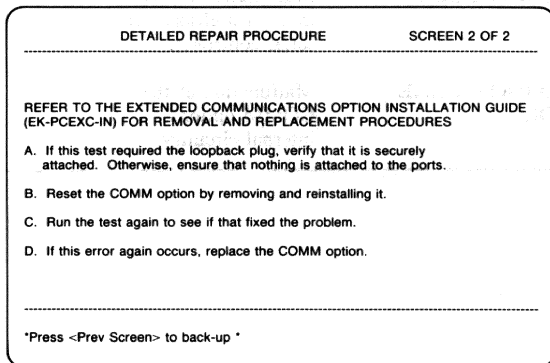

Figure C-9

Internal Test Error Message	Error Indicates	Corrective Action
FAILURE: COMM OPTION BOARD: (followed by:)		
DMA REGISTER DATA TEST	Malfunction in the internal direct memory access controller.	
DMA DIAGNOSTIC INTERRUPT		
COMMAND STATUS REGISTER RESET	Malfunction of the COMM option internal circuitry.	See Figures C-10 and C-11.
COMMAND STATUS REGISTER READ		
MPSC DATA BUS	Malfunction in the internal multiprotocol serial controller.	
BAUD RATE GENE- RATOR	Malfunction of the COMM option internal circuitry.	

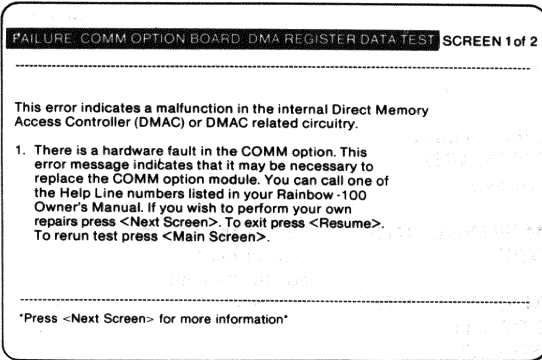

Figure C-10

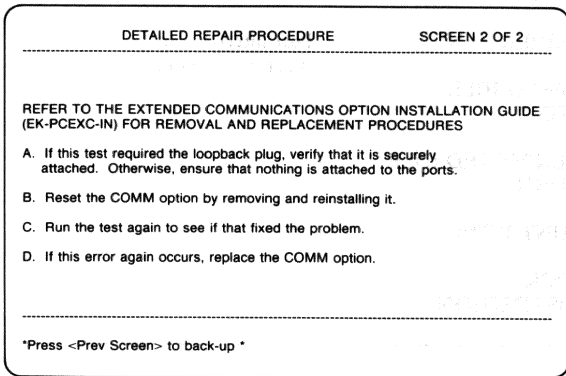

Figure C-11

External Test Error Message	Error Indicates	Corrective Action
External Testing		
FAILURE: COMM OPTION BOARD: (followed by:)		
COMM SIGNAL "DTR" TO "DSR"	One of the modem control lines is not functioning properly	See Figures C-12 and C-13.
COMM SIGNAL "RTS" TO "CTS" and "BRLSD/CD"		
COMM SIGNAL "SPSL" TO "RI"		
COMM SIGNAL "SRTS" TO "SI"		
CARRIER SENSE	Port interface not functioning properly.	
MISSING IDLE DETECT		
UNEXPECTED IDLE DETECT		
COUNT DONE		
CLOCK SUBSTITUTION		

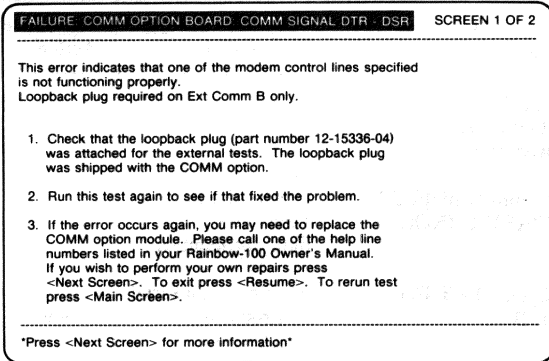

Figure C-12

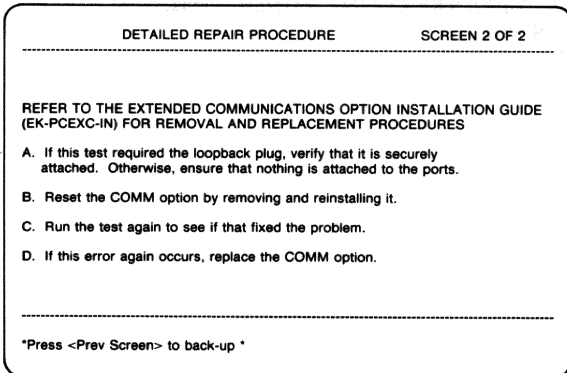

Figure C-13

External Test Error Message	Error Indicates	Corrective Action
FAILURE: COMM OPTION BOARD: (followed by:)		
Ext. Comm B BUFFER COMPARE ERROR	Received and transmitted data not identical.	
SYNC DETECT Ext. Comm B	Multiprotocol serial controller not synchronized.	See Figures C-14 and C-15.
DMA TERMINAL COUNT CHANNEL 0	Data transfer was not completed during allotted time for	
DMA TERMINAL COUNT CHANNEL 2	external loopback test.	

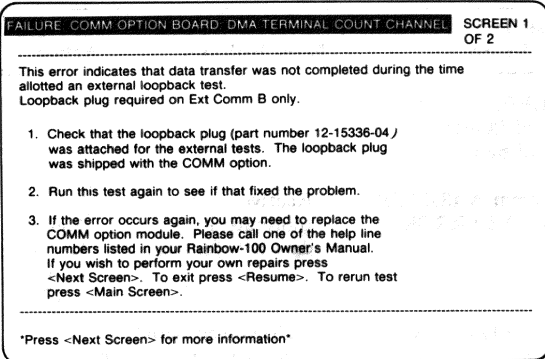

Figure C-14

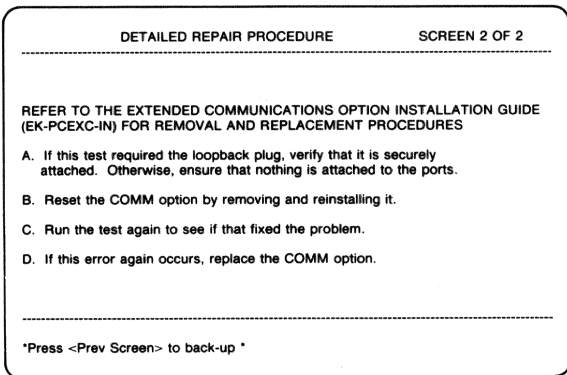

Figure C-15

External Test Error Message	Error Indicates	Corrective Action
FAILURE: COMM OPTION BOARD: (followed by:)		
Ext. Comm A BUFFER COMPARE ERROR	Received and transmitted data not identical.	See Figures C-16 and C-17.
SYNC DETECT Ext. Comm A	Multiprotocol serial con- troller not synchronized.	

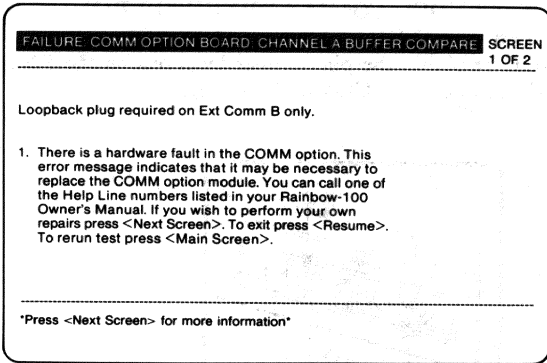

Figure C-16

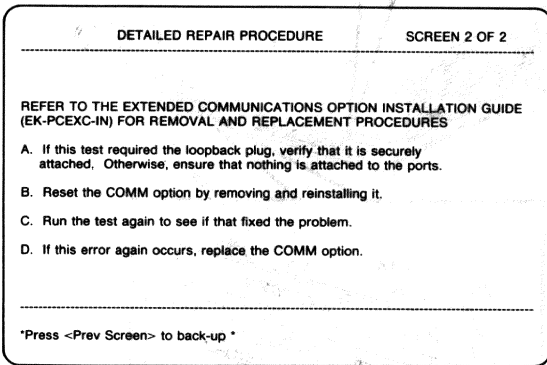

Figure C-17

C.4 EXTENDED COMM CONNECTOR PIN LOCATIONS

Figure C-18 shows the pin number locations on the,EXT COMM A and EXT COMM B connectors.

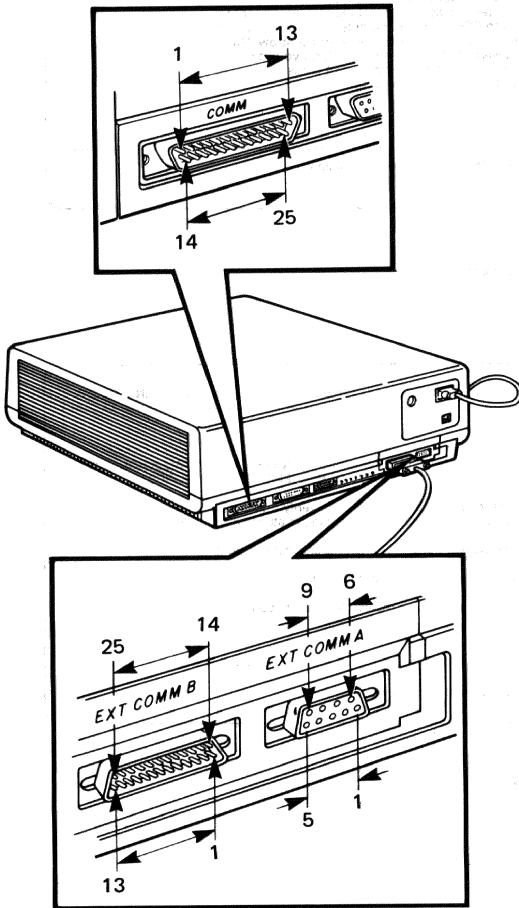

Figure C-18 COMM Connector Pin Assignments

D COLOR/GRAPHICS OPTION TEST PROCEDURE

D.1 INTRODUCTION

The color/graphics option test procedure is on the GSX-86 diskette that comes with the color/graphics option board (54-15688). The test procedure checks if the board is installed correctly. It also tests the circuits on the board. The test procedure also has a monitor alignment pattern that allows you to adjust the monitor.

If you have a black and white monitor (VR201-A), refer to Chapter 4 of this book for any adjustments. For all adjustments to your color monitor (VR241-A), see the *VR241-A Color Video Monitor Pocket Service Guide* (EK-VR241-PS).

Before changing the color/graphics option board, you should check that the external connector pins and the pins on the 40-pin connectors on the option board are not bent.

Reseat the option board and make sure that all the cable connectors on the system module are firmly in place, and that all the external cable connectors are secure.

Try testing the option board again, and if it fails, change the board.

D.2 TESTING

For these test procedures, you will need the graphics option hardware diagnostic tests on the GSX-86 diskette (BL-V174A-MV). Remove the GSX-86 diskette from its protective envelope and insert it into drive A.

D.2.1 Main GSX-86 Menu Access

To access the main GSX-86 menu, select the diskette drive that contains the GSX-86 diskette. Type A. The computer displays the main GSX-86 menu, shown in Figure D-1, on the screen.

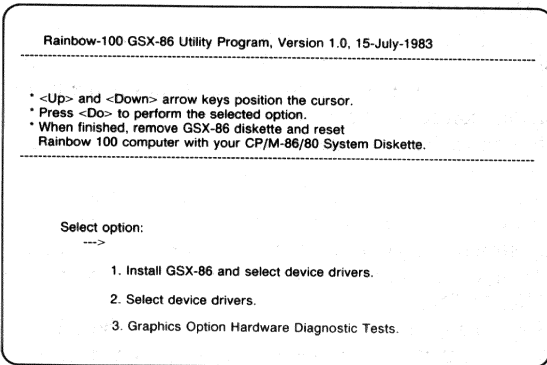

Figure D-1 Main GSX-86 Menu

To select the graphics option hardware diagnostic tests, position the cursor on option 3 by pressing the **▼** key three times. Then, press the **Do** key to perform the selected option.

D.2.2 Monitor Hardware Selection

Type **1**, **2**, or **3** to select the test for the type of monitor on your system. Then, press the **Return** key (Figure D-2).

INDIVIDUAL DIAGNOSTIC TEST: GRAPHICS OPTION DIAGNOSTIC

PLEASE SELECT ONE OF THE FOLLOWING:

1. THIS SYSTEM HAS A BLACK & WHITE MONITOR ONLY
2. THIS SYSTEM HAS A COLOR MONITOR ONLY
3. THIS SYSTEM HAS BOTH B/W AND COLOR MONITORS

** TO RETURN TO MAIN MENU, PRESS <Main Screen> **

TYPE SELECTION NUMBER, THEN PRESS <Return>:

Figure D-2 Monitor Hardware Selection

D.2.3 Select Tests

Figure D-3 shows the test selection menu. Type 1 to run complete graphics tests.

NOTE

The other selections run specific parts of test 1.

INDIVIDUAL DIAGNOSTIC TEST: GRAPHICS OPTION DIAGNOSTIC

PLEASE SELECT ONE OF THE FOLLOWING:

1. COMPLETE GRAPHICS TESTS	7. WHITE SCREEN
2. QUICK VERIFY	8. COLOR BARS
3. MONITOR ALIGNMENT PATTERN	9. SCROLLING TEST
4. RED SCREEN	
5. GREEN SCREEN	
6. BLUE SCREEN	

* TO RETURN TO MAIN MENU, PRESS <Main Screen>
* TO RETURN TO HARDWARE CHOICES, PRESS <Prev Screen>

TYPE SELECTION NUMBER, THEN PRESS <Return>

Figure D-3 Test Selection Menu

D.2.4 Starting Graphics Tests

To start the tests, press the **Return** key. As the computer performs each subtest, its title displays on the screen followed by the result: **Passed** or **Failed**. As the tests are running, you will see a screen similar to that in Figure D-4. In addition, you will also see various patterns during some of the tests.

INDIVIDUAL DIAGNOSTIC TEST: GRAPHICS OPTION DIAGNOSTIC	
SUBTEST 1: OPTION PRESENT?	PASSED
SUBTEST 2: SCROLL MAP	PASSED
SUBTEST 3: FIFO	PASSED
SUBTEST 4: STATUS REGISTER	PASSED
SUBTEST 5: CLOCK	PASSED
SUBTEST 6: INTERNAL SYNCHRONIZATION	PASSED
SUBTEST 7: TEXT/GRAPHICS MASK	PASSED
SUBTEST 8: CHARACTER BUFFER	PASSED
SUBTEST 9: MEMORY DATA AND REFRESH	PASSED
SUBTEST 10: GRAPHICS REGISTERS	PASSED

Figure D-4 Tests in Progress

D.2.5 Completed Graphics Tests

When all graphics tests are complete (Figure D-5), the system displays the statement

*****ALL TESTS COMPLETE!!*****

on the screen briefly; then, the main GSX-86 menu (Figure D-1) automatically displays.

- Remove the GSX-86 diskette.

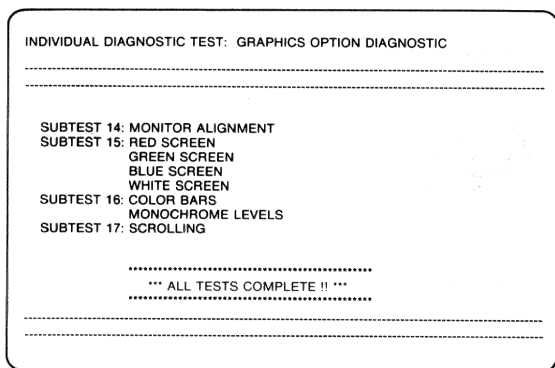

Figure D-5 All Tests Complete

D.2.6 Failed Graphics Test

If a graphics test fails, the system will display a message at the bottom of the screen showing which subtest failed. (See Figure D-6.)

INDIVIDUAL DIAGNOSTIC TEST: GRAPHICS OPTION DIAGNOSTIC	
SUBTEST 1: OPTION PRESENT?	PASSED
SUBTEST 2: SCROLL MAP	PASSED
SUBTEST 3: FIFO	PASSED
SUBTEST 4: STATUS REGISTER	PASSED
SUBTEST 5: CLOCK	PASSED
SUBTEST 6: INTERNAL SYNCHRONIZATION	PASSED
SUBTEST 7: TEXT/GRAPHICS MASK	PASSED
SUBTEST 8: CHARACTER BUFFER	PASSED
SUBTEST 9: MEMORY DATA AND REFRESH	PASSED
SUBTEST 10: GRAPHICS REGISTERS	FAILED

FAILURE: GRAPHICS OPTION: PATTERN REGISTER OR PATTERN MULTIPLIER

- TYPE P TO PROCEED OR L TO LOOP ON ERROR, THEN PRESS <Return>
- PRESS <Help> FOR MORE ERROR INFORMATION

Figure D-6 Screen with Failure Message

Write down the subtest number that failed and the error message, and refer to Paragraph D.3, and/or press the **Help** key for more error information. To exit Help, press the **Resume** key. Testing then restarts from the beginning.

D.2.7 Proceeding from an Error

You type **P** on the keyboard and press the **Return** key to continue the testing after each error encountered. If you type **L** and press the **Return** key, the message

-LOOPING ON ERROR: % ERROR = nnn

replaces the previous message.

After the test is performed 10 times, the percent failure is updated. To exit the loop, press the **Set-Up** key; then, press **<Ctrl/Set-Up>**.

The system displays the Main System Menu, and you will have to start the testing procedures from the beginning.

D.3 FAULTS, ERROR MESSAGES, AND CORRECTIVE ACTION

The Help message screens referred to in this section will only appear when a fault is present and you press the **Help** key. They cannot be accessed by any other means.

Error Message	Error Indicates	Corrective Action
FAILURE: GRAPHICS OPTION: (followed by:)		
GRAPHICS BOARD NOT PRESENT	Option not detected by the system.	See Figure D-7.
Internal Testing		
FAILURE: GRAPHICS OPTION: (followed by:)		
SCROLL MAP OR DATA BUS	Failure in the scroll map circuitry or the common data path.	See Figure D-8.
CONTROLLER OR DATA BUS	Proper cursor position not confirmed.	
CONTROLLER RETURNS INVALID STATUS	Controller status register is incorrectly set.	
CLOCK TIMING	Clock malfunctioning or graphics controller has failed.	
CONTROLLER INVALID SYNCHRONIZATION	Graphics controller's internal timing not synchronized.	

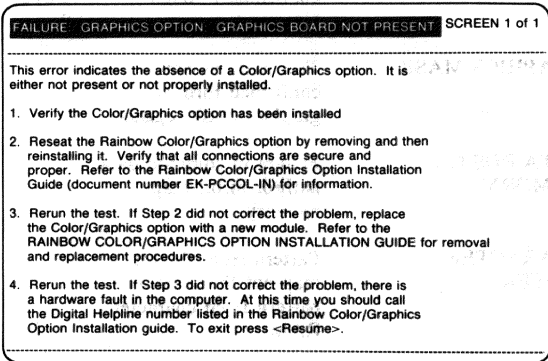

Figure D-7

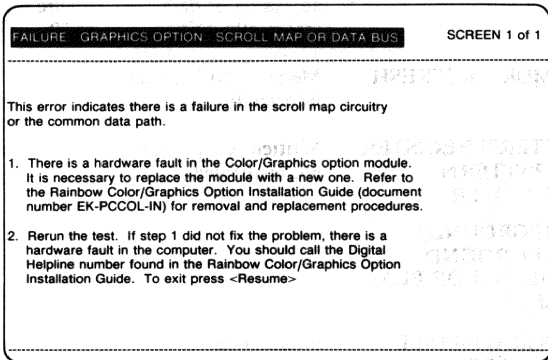

Figure D-8

Error Message	Error Indicates	Corrective Action
FAILURE: GRAPHICS OPTION: (followed by:)		
TEXT MASK	Test patterns not confirmed through text mask register.	See Figure D-9.
GRAPHICS MASK	Test patterns not confirmed through graphics mask register.	
DATA BUS OR MEMORY	Failure in common data path or in bit map memory.	
CHARACTER BUFFER	Pattern from the bit map not the same as pattern from character RAM.	
FAILURE: GRAPHICS OPTION: (followed by:)		
MEMORY DATA	Memory incorrect addressed or data incorrectly written.	See Figure D-10.
MEMORY REFRESH	Memory storing data incorrectly.	
PATTERN REGISTER OR PATTERN MULTIPLIER	Written test patterns not confirmed.	
FOREGROUND/ BACKGROUND REGISTER OR PLANE SELECT		
PROGRAMMABLE LOGIC ARRAY	Information incorrectly modified when written back to bit map memory.	
ERRATIC INTERRUPT	Failure of the interrupt logic.	
CONTROLLER OR ADDRESSING	Graphics controllers output failed.	

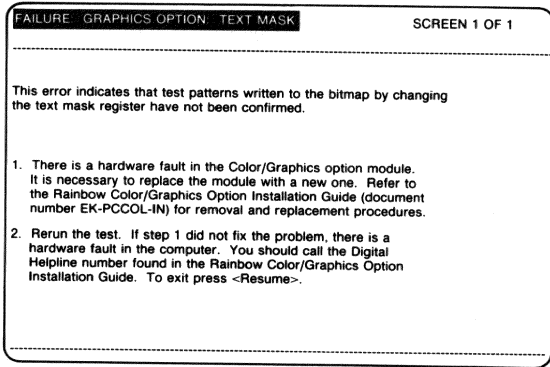

Figure D-9

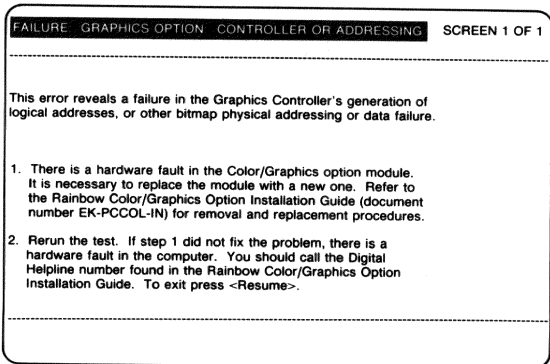

Figure D-10

The first part of the report deals with the general situation in the country. It is noted that the economy is in a state of depression, and that the government is unable to meet its obligations. The report also mentions that the population is suffering from a lack of food and clothing, and that the government is unable to provide for their needs.

The second part of the report deals with the situation in the various provinces. It is noted that the situation is similar in all provinces, with a lack of food and clothing, and a general state of depression. The report also mentions that the government is unable to provide for the needs of the population in any of the provinces.

The third part of the report deals with the situation in the various cities. It is noted that the situation is similar in all cities, with a lack of food and clothing, and a general state of depression. The report also mentions that the government is unable to provide for the needs of the population in any of the cities.

The fourth part of the report deals with the situation in the various districts. It is noted that the situation is similar in all districts, with a lack of food and clothing, and a general state of depression. The report also mentions that the government is unable to provide for the needs of the population in any of the districts.

The fifth part of the report deals with the situation in the various villages. It is noted that the situation is similar in all villages, with a lack of food and clothing, and a general state of depression. The report also mentions that the government is unable to provide for the needs of the population in any of the villages.

E WINCHESTER (HARD) DISK OPTION TEST PROCEDURE

E.1 INTRODUCTION

The Winchester disk option test procedure provides information on testing and initializing a hard disk drive and running the hard disk diagnostic. This procedure also lists the most common errors that occur when installing a hard disk drive. Other errors are listed in Chapter 3, Testing and Troubleshooting.

The field replaceable units (FRUs) for the hard disk option are as follows:

- Hard disk drive cable
- Hard disk drive
- Hard disk controller board

Before replacing any of the FRUs, make sure that the controller board is fully seated in both of its connectors, make sure the 4-wire power cable is connected to the hard disk drive, and make sure the hard disk drive cable is connected firmly to the controller board and to the hard disk drive. Make sure you know that a hard disk drive is bad before initializing, repartitioning, or replacing it. The hard disk drive holds as much data as 25 diskettes.

CAUTION

DO NOT initialize, test, repartition, or remove the hard disk drive unless the customer has back-up diskettes of all the files on the hard disk drive.

E.2 TESTING AND INITIALIZING THE HARD DISK DRIVE

Find the Rainbow hard disk utility program diskette in the user kit and insert it into diskette drive A. Close the drive door.

Testing and Initializing the Hard Disk

To test and initialize the hard disk, type A. The computer will display the screen shown in Figure E-1. If you see a message at the top of the screen, refer to page 22 for instructions. Now, type 1 to move the arrow to the first selection:

1. Test and initialize the hard disk.

Press the **Do** key; you will now see a message on your screen warning you that data on the hard disk will be destroyed. Press the **Resume** key. You will see the warning message repeated. Press the **Resume** key again. You will see the following message.

Testing hard disk controller

The computer then displays the screen shown in Figure E-2 with a time to completion message. You will have to wait for the program to count down to 0 seconds. You will then see the following message.

Initialization is in progress.

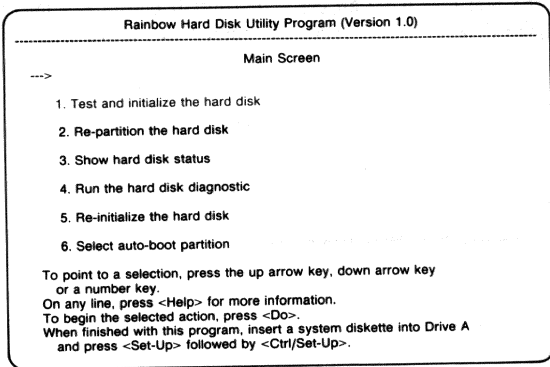

Figure E-1 Rainbow Hard Disk Utility Program Main Screen

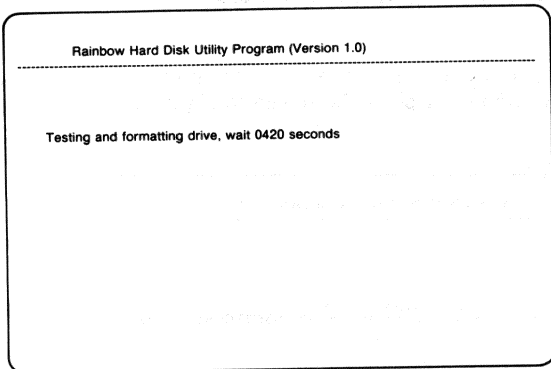

Figure E-2 Testing and Formatting Drive, Wait

If the test discovers an error or finds it cannot initialize the hard disk, it will display the screen in Figure E-3.

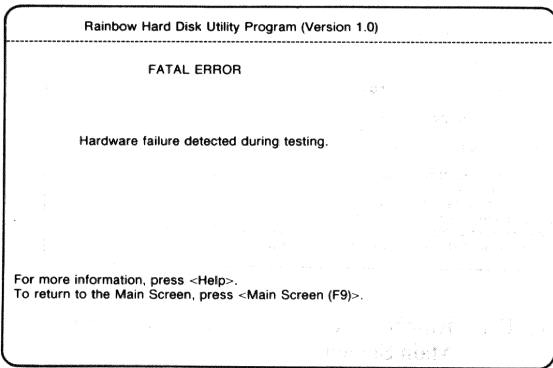

Figure E-3 FATAL ERROR Screen

When the testing and initialization process is complete, the computer displays the screen in Figure E-4.

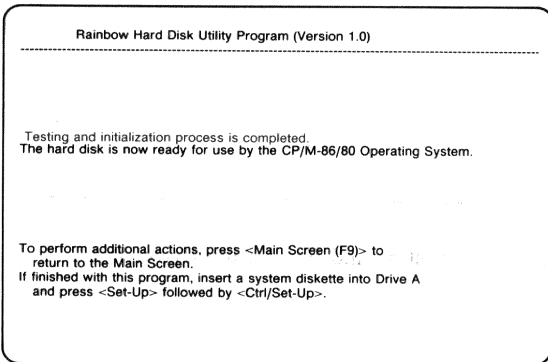

Figure E-4 Testing and Initialization Process Complete

NOTE

If you see any other message, the test did not pass. Press the Help key for further instructions. To exit the Help instructions, press the Resume key.

Remove the diskette in diskette drive A and return to the Main System Menu. To return to the Main System Menu, press the Set-Up key, then, press <Ctrl/Set-Up>.

E.3 RUN THE HARD DISK DIAGNOSTIC

Select number 4 from the Rainbow hard disk utility program diskette menu. This selection runs all the subtests in selection 1, and, in addition, prints all the subtest names and indicates if the subtest PASSED or FAILED. If the diagnostic is successful, the screen in Figure E-5 is displayed.

```

Rainbow Hard Disk Utility Program (Version 1.0)
-----
HARD DISK OPTION DIAGNOSTIC  REV 1.5
-----
                                     PASS 0000
SUBTEST #7: READ ALL SECTORS          PASSED
            WRITE SECTORS TEST
            IMPLIED SEEK (WRITE)      PASSED
            BASIC WRITE TEST 1       PASSED
            BASIC WRITE TEST 2       PASSED
            BASIC WRITE TEST 3       PASSED
SUBTEST #8: WRITE FORMAT TESTS       PASSED
*** DIAGNOSTIC COMPLETE ***
PRESS <RETURN> TO RETURN TO MAIN MENU.
-----

```

Figure E-5 Hard Disk Option Diagnostic Complete

If a subtest fails, the test stops and a failure message is displayed at the bottom of the screen. The more common failures that occur during installation are presented in Paragraph E.4.; all the hard disk error messages are shown in Table 3-2. Refer to this table for other error messages for the hard disk drive.

E.4 FAULTS, ERROR MESSAGES, AND CORRECTIVE ACTION

The following errors can occur most often while installing or replacing a hard disk drive.

THE HARD DISK OPTION IS NOT CONNECTED

This error occurs during selection 1, testing and initializing the hard disk drive. Press the **Help** key for more information. To exit the **Help** instructions, press the **Resume** key.

This error will occur if the hard disk controller is not fully seated in its connectors on the system module or it is missing.

FAILURE: HARD DISK CONTROLLER: R/W ERROR IN HEAD SELECT REGISTER

If substest 1 of the diagnostic fails and displays the screen in Figure E-6, the hard disk controller is not firmly seated on the system module.

Rainbow Hard Disk Utility Program (Version 1.0)		
HARD DISK OPTION DIAGNOSTIC		REV 1.5
SUBTEST #1: INTERNAL REGISTERS TEST		PASS 0000
SECTOR COUNT (R2)		PASSED
SECTOR NUMBER (R3)		PASSED
CYL NUMBER LOW (R4)		PASSED
CYL NUMBER HIGH (R5)		PASSED
SECTOR SIZE,DRIVE, HEAD (R6)		
FAILURE: HARD DISK CONTROLLER: R/W ERROR IN HEAD SELECT REGISTER		
* TYPE P TO PROCEED OR L TO LOOP ON ERROR, THEN PRESS <Return>:		
* PRESS <Help> FOR MORE ERROR INFORMATION.		

Figure E-6 Subtest 1 Failure: R/W Error in Head Select Register

Corrective Action

Perform the following steps.

1. Remove the system module (Paragraph 5.4).
2. Press down on the hard disk controller at all its connectors and standoffs making sure it seats firmly.

3. Install the system module in the system unit.
4. Make sure the hard disk cable is connected to the hard disk controller and to the hard disk drive.
5. Run the hard disk diagnostic test again.

FAILURE: DRIVE: DRIVE NOT READY

If subtest 2 fails its Restore test and displays the screen in Figure E-7, check for loose cable connections to the hard disk controller.

Rainbow Hard Disk Utility Program (Version 1.0)		
HARD DISK OPTION DIAGNOSTIC		REV 1.5
		PASS 0000
SUBTEST #1:	INTERNAL REGISTERS TEST	
	SECTOR COUNT (R2)	PASSED
	SECTOR NUMBER (R3)	PASSED
	CYL NUMBER LOW (R4)	PASSED
	CYL NUMBER HIGH (R5)	PASSED
	SECTOR SIZE, DRIVE, HEAD (R6)	PASSED
	COUNTER CLEAR TEST A	PASSED
	SECTOR BUFFER TEST A	PASSED
	SECTOR BUFFER TEST B	PASSED
	COUNTER CLEAR TEST B	PASSED
SUBTEST #2:	RESTORE TEST	
FAILURE: DRIVE: DRIVE NOT READY		
* TYPE P TO PROCEED OR L TO LOOP ON ERROR, THEN PRESS <Return>:		
* PRESS <Help> FOR MORE ERROR INFORMATION.		

Figure E-7 Subtest 2 Failure: Drive: Drive Not Ready

Corrective Action

1. Make sure the hard disk cable is fully seated on the hard disk controller. If that fails, remove the cable and look for bent pins on the controller or look for cable damage.
2. Make sure the hard disk cable is connected to the hard disk drive. When installing the cable connectors, install them straight on the gold pins of the hard disk drive. Do not install them at an angle to the gold pins or pin damage in the connector may result.
3. Make sure the 4-wire power cable is attached to the hard disk drive.

**FAILURE: HARD DISK CONTROLLER:
IMPROPER STATUS, COMMAND COMPLETION**

If subtest 4 fails its Seek/Scan test and displays the screen in Figure E-8, make sure the hard disk cable is connected to the hard disk drive.

Rainbow Hard Disk Utility Program (Version 1.0)		
HARD DISK OPTION DIAGNOSTIC		REV 1.5
		PASS 0000
SUBTEST #2:	COUNTER CLEAR TEST B	PASSED
	RESTORE TEST	PASSED
SUBTEST #3:	MOTOR TESTS	
	INDEX TEST A	PASSED
	INDEX TEST B	PASSED
	DRIVE ROTATION SPEED TEST	PASSED
SUBTEST #4:	SEEK TESTS	
	STEP FLAG TEST	PASSED
	TRACK 00 TEST	PASSED
	STEP TEST	PASSED
	SEEK TIMING TEST	PASSED
	SEEK/SCAN TEST	
FAILURE: HARD DISK CONTROLLER: IMPROPER STATUS, COMMAND COMPLETION.		
* TYPE P TO PROCEED OR L TO LOOP ON ERROR, THEN PRESS <Return>:		
* PRESS <Help> FOR MORE ERROR INFORMATION.		

**Figure E-8 Subtest 4 Failure: Hard Disk Controller:
Improper Status, Command Completion**

FAILURE: CONTROLLER OR DRIVE? : DATA ERROR, BAD WRITE OR READ

If subtest 7 fails its Basic Write Test 2 and displays the screen in Figure E-9, pin 3 on the large connector to the hard disk drive is damaged.

Rainbow Hard Disk Utility Program (Version 1.0)		
HARD DISK OPTION DIAGNOSTIC		REV 1.5
		PASS 0000
SUBTEST #6:	CLEAR ERROR TEST	PASSED
	FORCE I.D. NOT FOUND	PASSED
	READ SECTORS TEST	
	IMPLIED SEEK TEST (READ)	PASSED
	BASIC READ TEST	PASSED
	TRACK 00 TEST (READ)	PASSED
	DATA INTEGRITY TEST	PASSED
	READ ALL SECTORS	PASSED
SUBTEST #7:	WRITE SECTORS TEST	
	IMPLIED SEEK (WRITE)	PASSED
	BASIC WRITE TEST 1	PASSED
	BASIC WRITE TEST 2	
FAILURE: CONTROLLER OR DRIVE? : DATA ERROR, BAD WRITE OR READ * TYPE P TO PROCEED OR L TO LOOP ON ERROR, THEN PRESS <Return>: * PRESS <Help> FOR MORE ERROR INFORMATION.		

**Figure E-9 Subtest 7 Failure: Controller or Drive ?,
Data Error, Bad Write or Read**

Corrective Action

Perform the following steps.

1. Remove the cable from the hard disk drive and check pin 3 on its large connector.
2. If the pin cannot be straightened, install a new cable (part number 17-00427-01) on the disk drive. Refer to Paragraph 5.13 for instructions.

NOTE

When removing or installing the connectors on the hard disk drive, remember to remove or install them straight on the gold pins of the disk drive. Do not remove or install the connectors at an angle to the pins.

1911

THE HISTORY OF THE UNITED STATES

CHAPTER I
THE EARLY HISTORY OF THE UNITED STATES

The first European to set foot on the continent of North America was Christopher Columbus in 1492. He was sailing for Spain in search of a westward route to the Indies. On October 12, 1492, he landed on the island of San Salvador in the Bahamas.

Other European explorers followed Columbus, including John Cabot, who sailed for England in 1497, and Amerigo Vesputi, who sailed for Italy in 1498. They discovered the eastern coast of North America.

The first permanent European settlement in North America was founded by the Pilgrims in 1620. They sailed on the Mayflower and landed in Plymouth, Massachusetts.

The Pilgrims were a group of English Puritans who had fled their home country in search of religious freedom. They established a self-governing community in Plymouth.

Other early settlements were founded by the Jamestown colonists in 1607 and the Roanoke colonists in 1585. The Roanoke colony, however, disappeared without a trace.

The early history of the United States is marked by the struggles of the colonists for independence from British rule. The American Revolution began in 1775 and ended in 1783.

The United States Declaration of Independence was signed on July 4, 1776. It declared the colonies to be free and independent states.

INDEX

A

- Aspect ratio with graphics, 69
- Auto repeat, 8
- Auto-answerback, 10
- Auto-boot Set-Up menu, 14, 15
- Auto-screen blank, 9
- Auto-wrap, 9
- Auto-XON/XOFF, 9

B

- Bell volume, 14
- Brightness and contrast, 60

C

- Cable part numbers, 126, 127
- Character codes, 11
- Color/graphics board removal, 84
- Color/graphics diagnostic messages, 48, 49, 174-177
- Color/graphics option test procedure, 167
- Comm connector pin numbers, 166
- Correspondence/data processing, 8
- CP/M-80/86, 1
- Cutoff control, 67

D

- DC fan, 3
- Diagnostic diskette, 33
- Diagnostic diskette test messages, 35-49
- Diagnostic error lights, 19, 21-25
- Disconnect character use, 10
- Disconnect delay, 10
- Diskette care, 53, 54
- Diskette drive removal, 91, 92

E

- 8088 processor, 1, 4
- Emulation, 8
- Enabling auto-boot from hard disk, 15
- Error messages, 21-25
- Ext. comm. board removal, 84
- Ext. comm. diagnostic messages, 46-48, 155-165
- Ext. comm. option test procedure, 149

F

- Fan bracket assembly removal, 100
- Fan removal, 103, 104
- Focus, 62

H

- Hard disk controller removal, 85, 86
- Hard disk diagnostic error messages, 42-45, 184-187
- Hard disk drive installation, 98, 99
- Horizontal centering, 64
- Horizontal centering with graphics, 68
- Horizontal hold, 62

I

- Individual test menu, 50
- Install new diagnostic test, 53

K

- Keyboard language selection, 11
- Keyboard replacement, 100
- Keyclick volume, 14
- Keyclick, 9

L

- Language ROM, 87, 89, 90, 125, 126
- Language selection menu, 11
- LK201-AA keyboard, 2
- Local and line modes, 6
- Local echo, 9
- Lock mode, 10
- Loopback plugs, 52, 126

M

- Margin bell, 9
- Memory board removal, 83
- Memory option test procedure, 129
- Memory Set-Up menu (PC100A only), 16
- Modem protocol, 12
- Modem Set-Up menu, 12
- Modem stop bits, 10
- Monitor adjustments, 55
- Monitor module removal, 114
- Monitor removal, 113
- MS-DOS, 1
- Multinational character set, 11

N

- New line mode, 9

P

- Parts list, 125
- Power supply removal, 105–113
- Power supply voltage setting, 113
- Power supply, 3
- Power switch removal, 102
- Print extent, 9
- Print termination character, 9
- Printer Set-Up menu, 13
- Printers, 2

R

- Rainbow computer comparison, 3
- Recall Set-Up features, 5
- Receive character parity, 10
- Reference manuals, xii, 2
- Removal and replacement procedures, 73–123
- Removing system unit from floor stand, 75
- Restore default Set-Up values, 6
- ROM removal, 86–90
- RX50 controller module removal, 82

S

- Save Set-Up features, 5
- Screen jitter, 9
- Screen width, 8
- Scroll rate, 14
- Scroll, 8
- Set-Up features, 5
- Set-Up menus, 7–17
- System block diagram, 4
- System module number, 3
- System module removal, 77–80

T

- Terminal mode, 7
- Testing and troubleshooting, 19
- Testing strategy, 19
- Total memory capacity, 3
- Transmit break, 9

V

- Vertical centering with graphics, 64
- Vertical centering without graphics, 63
- Vertical hold, 61
- Vertical linearity, 67, 70
- Video alignment pattern, 50, 51
- Video alignment template, 127
- VR201-A monitor, 2

W

- Winchester (hard) disk option
test procedure, 177
- Winchester disk drive removal, 93, 94

X

- XON/XOFF (see Auto-XON/XOFF)

Z

- Z80A processor, 1, 4

